

A close-up photograph of the waist area of a pair of blue denim jeans. The jeans feature prominent orange stitching along the seams and pocket edges. A small red Levi's brand label is visible on the right side of the waistband. The background is a blurred, light-colored fabric, possibly a shirt.

# LEVI STRAUSS & CO. 2025 SUPPLIER CODE OF CONDUCT

## IMPLEMENTATION GUIDEBOOK

VALID MARCH 2025

# Contents

Introduction	1	Electrical Safety	78
Ratings Defined	2	Control of Hazardous Energy / Lock-Out/Tag-Out	81
Labor Standards – Supplier Code of Conduct	4	Machine Guarding	84
Labor	5	Powered Industrial Trucks	87
Child Labor	6	Noise Management	90
Prison, Forced, or Trafficked Labor	9	Personal Protective Equipment	92
Disciplinary Practices	13	Ventilation	95
Legal Requirements	20	Chemical Management	97
Ethical Standards	22	Extreme Temperatures	101
Working Hours	25	Asbestos Management	103
Wages and Benefits	27	Occupational Exposure	105
General Labor Practices and Freedom of Association	31	Signs and Labels	108
Discrimination	37	Maintenance	110
Community Involvement	41	Finishing Guidelines	112
Foreign Migrant Workers	42	Finishing Safety Guidelines	113
Dormitories	50	Hand Scraping	115
Permits	55	Laser Engraving	117
Environment, Health & Safety	56	Spraying	120
Safety Guidelines	59	Curing	123
Safety Committees	60	Dipping and Sponging	125
Risk Assessment	62	Screen printing	127
Multi-Story Building Risk Management	64	Abrasive Blasting	129
Emergency Preparedness	66	Ozone	130
Building Integrity	69	Health Guidelines	134
Aisles and Exits	72	Health Training	135
Lighting	74	Water, Sanitation, Hygiene (WASH)	140
Housekeeping	76	Canteen	142

First Aid	145	Communicable Diseases	227
Common Diseases	148	COVID-19 Preventive Recommendations for Vendors	238
Preventing Communicable Disease	150	Annex C: Environment Guidelines	248
Pandemic Management	153	Waste Management	248
Environmental Guidelines	154	Transporting Hazardous Materials	248
Energy Management	155	Hazmat Transportation Inspections Information	248
Water Management	156	Loading/Unloading Inspection	248
ZDHC Wastewater Requirements (formerly ‘Global Effluent Requirements’)	157	Transporting Hazardous Materials	255
Bio-solids Management	158	Sample Bulk Fuel Oil Transfer Procedures	255
Preventing Storm Water Pollution	160	Hazardous Materials and Waste Management – Emergency Procedures	256
Aboveground/ Underground Storage	162	Sample Facility Site Plan/Storage Map	257
Waste Management	164	Facility Evacuation Map Template	258
Transporting Hazardous Materials	167	Sample Hazardous Waste Storage Area Weekly Inspections Checklist	259
Solid Waste Management	174	Emergency Procedures for Spill or Release	260
Annex A: Safety Guidelines	178	Typical Hazardous Materials Inspection Violations	267
Safety Committees	178	Typical Fire Safety Inspection Violations	272
Emergency Preparedness	181	Solid Waste Management	277
Aisles and Exits	193	Preventing Storm Water Pollution	279
Housekeeping	195	Aboveground and Underground Storage Tanks	288
Electrical Safety	197	Glossary	296
Lock-Out/Tag-Out	198		
Machine Guarding	200		
Chemical Management	211		
Extreme Temperatures	214		
Asbestos Management	216		
Annex B: Health Guidelines	218		
Health Training	218		
First Aid	222		

# Introduction

In 1991, in line with our company values, Levi Strauss & Co. established a set of Global Sourcing and Operating Guidelines (GSOG). We created the GSOG to help us improve the lives of workers manufacturing our products, make responsible sourcing decisions, and protect our commercial interests. At the time they were developed, our GSOG were considered highly innovative; today, such codes of conduct have become a standard for responsible sourcing.

Initially, our GSOG were based on our company values and standards set by the United Nations, particularly the Universal Declaration of Human Rights and many of the International Labor Organization's (ILO) Core Conventions. Over time, in the spirit of continuous improvement, we have modified our GSOG in response to the suggestions of non-governmental organizations (NGOs) and to reflect the lessons we have learned through our own experience. Our GSOG is a cornerstone of our sourcing strategy and of our business relationships with hundreds of contractors worldwide.

## THE GSOG IS MADE UP OF TWO COMPONENTS:

- Country Assessment Guidelines address significant external issues beyond the control of Levi Strauss & Co.'s business partners. These help us assess the opportunities and risks of doing business in a particular country.
- The Business Partner Supplier Code of Conduct (SCOC) – formally known as Terms of Engagement - which deals with issues that are substantially controllable by individual business partners. These SCOCs are an integral part of our business relationships. Our employees and business partners understand that complying with our SCOC is just as important as meeting our quality standards and delivery times.

The SCOC helps us select and engage with business partners who follow workplace standards and business practices consistent with our values.

**Empathy**  
**Originality**  
**Integrity**  
**Courage**

**These four core values are at the heart of Levi Strauss & Co. They are fundamental to our success. They are the foundation of our company, define who we are. They underlie our vision of the future, our business strategies and our decisions, actions and behaviors.**

**We live by them.**  
**They endure.**

These requirements apply to every factory, subcontractor, licensee, agent, or affiliate that manufactures or finishes products for Levi Strauss & Co. All of our business partners are required to meet the requirements stipulated in the SCOC.

## RATINGS DEFINED

### Zero Tolerance Violation **ZTV**

A Zero Tolerance Violation is a serious breach of the Supplier Code of Conduct that LS&Co. believes could result in severe impact to individual rights, life safety, and/or LS&Co.'s corporate reputation. Production cannot be placed with proposed suppliers that have ZTVs. For existing suppliers with a ZTV confirmed by more than one source of information, LS&Co.'s approach is to work with these suppliers to remediate ZTVs immediately and endeavor to limit exit to circumstances when a supplier is unwilling to remediate promptly or does not have the capability to do so.

Examples of ZTV include underage workers; forced labor; corporal punishment; violation of ethical standards; infringements on freedom of association; failure to entitle legal minimum wage; egregious working hours; falsification of records; unauthorized subcontracting; and failure to complete ZT or IA+ [defined below] corrective actions within the agreed-upon timeframe.

### Immediate Action+ Item **IA+**

Immediate Action+ Violation is a breach of the Supplier Code of Conduct that LS&Co. believes poses a high risk or adverse impact to individual rights and life safety and/or LS&Co.'s corporate reputation. Production may not be placed with proposed suppliers who are IA+ certified, depending on the situation. For suppliers with an IA+ confirmed, LS&Co.'s approach is to work with these suppliers to remediate IA+ within a maximum period of one month fully, or the issue will become Zero Tolerance.

Examples of IA+ violations include non-payment of overtime premiums; non-provision of required government benefits; failure to prepare or provide documentation on essential labor issues such as age, hours, and wages; excessive working hours, force workers to perform overtime; use of verbal abuse or abusive disciplinary tactics or procedures; discrimination; failure to provide adequate emergency exits; inadequate fire prevention; violation of local law and not having valid building safety certificate.

### Immediate Action Item **IA**

An Immediate Action Item is a breach of the Supplier Code of Conduct that LS&Co. believes would result in a negative impact on individual rights, life safety, and/or LS&Co.'s corporate reputation. For suppliers with an IA, the violation must be fully remediated within a maximum period of two months; otherwise, the issue becomes a High-Risk Violation (IA+). Some IA violations may require a remediation period of less than two months.

Examples of IA violations include excessive working hours; Security guards allowed to intimidate or restrict the movement of workers; there is no confidential and secure communication channels for workers to raise concerns or grievances; failure to establish or enforce proper disciplinary processes; violation of local law; non-availability of all legal permits and non-functioning water treatment facility.

### Continuous Improvement Item **CI**

A Continuous Improvement Item is a labor, health, and safety, or environmental issue that LS&CO. believes the factory should address to enhance the well-being of its workers and/or improve the factory's reputation or management practices. Production can be placed with proposed suppliers who have CI issues. For proposed and existing suppliers with CI issues, a reasonable corrective action plan can be proposed over a period of four to six months.

Examples of CI items include communication and training on policies and procedures, operating permits applied for but not yet obtained, and complete company policies on, for example, hiring practices.

### Recommended Methods of Verification:

The recommended methods of verification are designed to illustrate how compliance with SCOC standards may be substantiated. Each technique, by itself, may not determine whether issues exist in a factory, but the combination of one or more will provide a more comprehensive picture of what is occurring. In this Guidebook, after each SCOC requirement is listed, a suggested method of verification will follow.

### The Methods of Verification are:



**Visual Observation**



**Records Review**

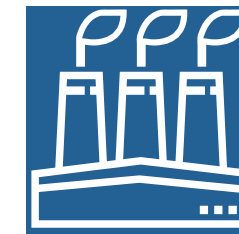

**Factory Management Interviews**

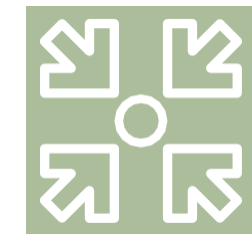

**Gathering Info From External Resources**



**Gathering Info From Workers**

# Labor Standards – Supplier Code of Conduct



## LABOR

The purpose of this Guidebook is to assist individuals, including factory managers, licensees, and agents, in implementing the Supplier Code of Conduct (SCOC) in factories that produce Levi Strauss & Co. (LS&Co.) products.

LS&Co. developed the SCOC requirements on its own initiative in 1991 and has since refined these requirements based on information obtained from sources, including but not limited to factories, licensees, monitors, NGOs, SCOC assessors, manufacturing and operations staff, and industry colleagues.

It should be emphasized that the creation of the Guidebook is an effort to provide guidance and ensure broad awareness and global consistency on SCOC issues that may be encountered worldwide and to underscore to our contractors the importance of complying with our SCOC requirements. This Guidebook was also created to ensure that problems are addressed correctly and promptly.

## CONTENTS OF THE LABOR CHAPTER

### SCOC Requirements

Each requirement is preceded by the acronym (see [page 1](#) for further explanation):

- ZTV** – Zero Tolerance Violation
- IA+** – Immediate Action+
- IA** – Immediate Action
- CI** – Continuous Improvement

We have included the suggested rating for each of the SCOC requirements. The recommended ratings will help the users of this Guidebook understand how seriously Levi Strauss & Co. views each issue.

In addition to the SCOC requirements, we have included specific examples of how the requirements can be applied to non-compliance issues that might arise in a factory.

These examples are based on our experience and are relatively comprehensive; however, they are not inclusive of every issue that may arise in a factory. However, they do illustrate the judgment used in determining compliance with or violation of the SCOC.

For each example of non-compliance, there is an accompanying suggestion for remediation, along with a specified timeframe for addressing the non-compliance.

If, after consulting this Guidebook, other SCOC tools, LS&Co.'s values, and one's judgment, there are still questions about what constitutes a violation, what remediation or timeframe to suggest, or what are considered best practices, please contact the LS&Co. Regional Sustainability Manager for further advice.

## CHILD LABOR

**The use of child labor is not permissible. Workers must be at least 15 years of age and not younger than the compulsory school age. We will not utilize partners who use child labor in any of their facilities. We support the development of legitimate workplace apprenticeship programs for the educational benefit of younger people.**

### Requirements

#### Minimum Working Age

**ZTV** The factory is prohibited from employing any worker under the age of 15.<sup>1</sup>

**ZTV** Where local law specifies a minimum working age higher than 15, all workers must be at or above the legal minimum age.

**ZTV** Where local law specifies a mandatory schooling age, the factory may only employ those persons above the age of compulsory schooling.

**IA+** Only persons at or above the age of 15 may be present in the work areas. Persons under the age of 15 may only be allowed on the premises in very exceptional and legally acceptable cases, such as the presence of on-site childcare facilities, provided these are not located within the work areas where the brand's products are produced. In no case may persons under the age of 15 enter working areas.

**IA+** The factory must have age-verification procedures that are effectively implemented so that every personnel file contains copies of the identified documents (such as birth certificates, national ID cards, or school certificates) submitted by applicants.

**IA** Factory should have a hiring policy that includes a minimum age of 15 or older if specified by law.

<sup>1</sup> ILO Minimum Age Convention, 1973, <https://is.gd/VlpXtF>

## Juvenile Workers

**IA+** Where a country's legal code specifies juvenile employment restrictions or requirements, the factory must be in compliance with the local legal requirements unless they are less stringent than the LS&Co. requirements, in which case the LS&Co. requirements must be met

**IA+** Juvenile workers are prohibited from working at night or conducting "hazardous work" as defined by the ILO.<sup>2</sup>

**Note 1:** LS&Co. defines a child as anyone under the age of 15 and a juvenile as anyone between the ages of 15 and 18. However, in regions or countries where the legal definition of a child includes persons older than 15, the local definition will apply.

Calculate age based on the whole years lived, not on years that began at birth. Thus, 12 months from birth, a person is considered to be one year old, not two years old. Additionally, at 14 months from birth, a person is still considered one year old, not two years old.

**Note 2:** According to the ILO, the definition of Hazardous Work about Child Labor consists of:

- Work that exposes children to physical, psychological, or sexual abuse;
- Work underground, underwater, at dangerous heights, or in confined places;
- Work with dangerous machinery, equipment, and tools, or work that involves the manual handling or transport of heavy loads;
- Work under particularly difficult conditions, such as working long hours or at night, or in situations where a child is unreasonably confined to the employer's premises.
- Work in an environment that may expose children to hazardous substances, agents, or processes, as well as excessive temperatures, noise levels, and vibrations that can be damaging to their health.

<sup>2</sup> ILO Night Work of Young Person (Industry) Convention, 1919, <https://is.gd/XspGoP>

**CHILD LABOR**  
**Non-Compliance & Corrective Actions**

Finding	Corrective Action	Recommended Timeline	Verification Method
<b>ZTV – Minimum Working Age:</b> In “X” country, the legal minimum working age is 14. One worker in factory “X” is 14 years old. Documentation verified the worker’s age.	Emergency child labor intervention must immediately be put in place, wherein the child is removed from the workplace even though at age 14 his or her employment is permissible under local law. The child should have the option to work in the factory once he/she has reached the legal working age.	Immediately	
<b>ZTV – Minimum Working Age:</b> In “X” country, the legal minimum working age is 16 (higher than LS&Co.’s SCOC 15-year requirement). There are 15-year- old juveniles working inside the factory. Documentation verified the workers’ ages.	Emergency child labor intervention must immediately be put in place, wherein the child is removed from the workplace.	Immediately	
<b>ZTV – Minimum Working Age:</b> In “X” country where the laws are somewhat conflicting, and juveniles are legally permitted to work after the age of 15 but must remain in school until the age of 16, one worker is 15 years of age and is not in school. Documentation verified the worker’s age.	The factory must implement a program to ensure that underage workers work only in accordance with law (e.g., limited hours that do not interfere with mandated schooling).	Immediately	
<b>CI – Minimum Working Age:</b> The factory has no policy on minimum hiring age.	Factory should establish policy on Minimum Hiring Age. Relevant staff to be trained on the implementation of the policy.	One week	
<b>IA – Juvenile Workers</b> In “X” country where juveniles are legally defined as workers between the ages of 15 and 18, the labor code states that juveniles are not allowed to work overtime. In factory “X” juveniles work the same hours (including overtime) as adult workers. This is confirmed by factory work records.	Identify juvenile employees and communicate to supervisors and workers the required legal employment restrictions. Create/maintain juvenile registry and implement juvenile employment restrictions (e.g., required written permission from parent/ guardian, special record-keeping, required medical exams, restricted work hours (no OT) and restrictions on jobs (no hazardous jobs).	One week	
<b>IA – Juvenile Workers</b> A child is discovered in the workplace. It is determined that the child was on holiday from school and was visiting her mother in the workplace.	The child must be removed from the work area. A policy must be established that prohibits children in the work area, and this policy must be communicated to workers.	Remove child immediately / one week to establish policy	

**PRISON, FORCED OR TRAFFICKED LABOR**

We will not utilize business partners who use prison, forced, or trafficked labor, nor will we utilize or purchase materials from a business partner utilizing prison, forced, or trafficked labor.

The general definition of forced labor is any work or service performed under the menace of <sup>1</sup>Penalty, and for which the said persons have not offered up themselves voluntarily.<sup>3</sup>

There are four common forms of forced labor:

- 1. Prison Labor:** Work performed by individuals incarcerated by either the state or military that is a requirement of their sentence and usually without compensation.
- 2. Indentured Labor:** Work performed by an individual contractually bound to an employer for a specific time period, which is usually in return for payment of travel and living expenses.
- 3. Bonded Labor:** An illegal practice in which employers provide high-interest loans to workers, who then, either individually or as a family, work at low wages to repay the debt.
- 4. Trafficked Labor:** a practice where a person is recruited, harbored, obtained, transported, or transferred with a view to that person being exploited.<sup>4</sup>

**Requirements**

**ZTV** All forms of prison or forced labor are prohibited.<sup>5</sup>

**ZTV** All use of trafficked labor, whether the contractor is using labor that has been trafficked or facilitating the trafficking of individuals for their exploitation by another party, is prohibited.

**ZTV** Any subcontracting arrangement with prisons is prohibited.

**ZTV** Factories must not require or allow employment agents to require any monetary deposits or keep any original identification documents. The practice of requiring deposits (money or original identification) may prevent workers from freely ending their employment within the legal context. This violation is most prevalent among migrant labor forces.

**IA+** The practice of excessive notice periods or substantial fines for terminating their employment contracts is prohibited. Labor contracts must also meet legal requirements.

<sup>3</sup> Definition established by the ILO, Forced Labour Convention, 1930, <https://is.qd/7qjVoC>

<sup>4</sup> Palermo Protocol 2000, <http://www.ohchr.org/EN/ProfessionalInterest/Pages/ProtocolTraffickingInPersons.aspx>

<sup>5</sup> Forced Labour Convention, 1930 and Abolition of Forced Labour Convention, 1957, <https://is.qd/mZit6S> Universal Declaration of Human Rights, 948, <https://www.un.org/en/universal-declaration-human-rights/>



**IA+** Security must not be allowed to intimidate or restrict the movement of workers. If security is inside the factory, they should not be armed.

**IA+** Factories must not restrict or limit in any way employee access to religious facilities, toilets, or drinking water.



**IA+** Overtime must be strictly voluntary. Any form of pressure to perform overtime is prohibited.

**Note:** If a factory advances payment to workers and withholds a small amount from each paycheck, allowing the worker to pay off the advance, this does not necessarily imply an SCOC violation.

Even though the worker is offering labor to pay off a loan, as long as the withheld amount does not violate local, legal restrictions concerning payroll deductions, it is not a violation of the SCOC.

## PRISON, FORCED OR TRAFFICKED LABOR Non-Compliances & Corrective Actions

Finding	Corrective Action	Recommended Timeline	Verification Method
<p><b>ZTV – Forced or Trafficked Labor:</b></p> <p>During an assessment, workers state that they are not working at the factory voluntarily. After further examination, it is found that the allegations are true.</p>	<p>The factory must discontinue the practice immediately. All workers must be working at the factory of their own free will and have a contract meeting all the legal employment requirements.</p>	<p>Immediately</p>	
<p><b>ZTV – Prison Labor:</b></p> <p>LS&amp;Co. contracts with a joint venture factory who is affiliated with the state. The factory purchases leather from a state-owned enterprise that employs prisoners.</p>	<p>The factory must discontinue the practice immediately and identify for LS&amp;Co. all leather goods made by prisoners.</p>	<p>Immediately</p>	
<p><b>ZTV – Forced Labor:</b></p> <p>In factory “X”, foreign migrant workers are required to sign a contract which states that they cannot resign. (For example, doing so within 2 years would mean substantial fines equivalent to 3 months of work.)</p>	<p>The contracts must immediately be revised and the clause removed. Workers should sign the revised contracts and be given a copy of the newly signed contracts. Termination of a contract must not result in a fine or a loss of previously earned wages.</p>	<p>Immediately</p>	
<p><b>ZTV – Forced Labor/Freedom of Movement:</b></p> <p>The factory requires workers to submit original copies of birth certificate or national ID documents or deposit money, or any legal identification papers (unless requested by workers for security reasons), so workers cannot easily leave or resign from the factory.</p>	<p>The factory must return all deposits; copy and then return all these documents to the workers and put a stop to the practice. The factory must have a policy/process in-place for workers who want to terminate employment (resigning) and this should be communicated to workers. Provide workers with means for securing money and/or papers themselves (e.g., secure storage).</p>	<p>2 weeks</p>	
<p><b>IA – Forced Labor:</b></p> <p>In factory “Y”, when workers request permission to leave work to care for their children who are ill, they are not granted permission to leave.</p>	<p>Under reasonable circumstances, immediately allow workers to leave the premises as they desire. Provide security as needed. Develop policies that allow workers to leave work under reasonable circumstances. Supervisors and workers must be trained on the policies.</p>	<p>Immediately / 3 weeks for policies and training</p>	

Finding	Corrective Action	Recommended Timeline	Verification Method
<b>IA – Freedom of Movement:</b> The workers feel as though they work in a climate of intimidation created by the presence of guards throughout the workplace, effectively restricting workers’ freedom of movement throughout the factory.	The factory must clarify the job description of security guards. Their revised job duties must be communicated to the guards and to the workforce. The guards must be monitored for compliance.	2 weeks	
<b>IA – Freedom of Movement:</b> Whenever workers want to go to the toilet or get a drink of water, they have to ask permission of their respective supervisor. The supervisor keeps track of how long employees are gone to make sure that workers do not waste too much time using the toilet.	Workers must have access to toilets and drinking water at all times and need not seek permission. There must be no restrictions on workers in performing traditional religious obligations.	Immediately correct practice/ 2 weeks to revise policy	

## DISCIPLINARY PRACTICES

We will not utilize business partners who use corporal punishment or other forms of mental or physical coercion.<sup>6</sup>

### Requirements

**ZTV** Factory managers/supervisors must never threaten the use of or practice any form of physical discipline or harmful physical contact, no matter how slight.

**ZTV** Factories must have a policy that prohibits sexual harassment, including unwelcome romantic and/or sexual advances, unwanted hugs and touching, suggestive or lewd remarks, requests for sexual favors, or the display of indecent, derogatory, or pornographic pictures, posters, drawings, or videos. Engaging in or allowing sexual harassment in any form is not acceptable in the workplace or any facilities related to the workplace, including on transportation and in dormitories.

Furthermore, employees shall not offer preferential work assignments or provide any other form of preferential treatment in exchange for a sexual relationship, nor shall they subject employees to prejudicial treatment in retaliation for refusing sexual advances. Further, the policy should include:

- Who the policy applies to: all employees or workforce members, regardless of status or contract type, visitors, customers, clients, and subcontractors.
- Where the policy applies: to workplace premises, in dormitories, on transportation to and from work, business trips, and off-site events or training sessions.
- Escalating disciplinary measures for employees engaging in sexual harassment that are effectively and extensively communicated to all levels of workers and management.
- A declaration that the policy prohibits all forms of violence and harassment in the workplace (i.e., physical abuse, psychological abuse, verbal abuse, and sexual harassment).
- A clear definition of each form of violence and harassment, alongside relevant examples of each.

**IA** Factories must have confidential and secure communication channels for workers to raise concerns or grievances to management and have procedures in place to protect workers from retaliation in response to making these complaints. These processes must be functional and effective – they must be accessible, used, and understood by workers, and they must also include a mechanism to ensure that grievances are addressed.

<sup>6</sup> ILO Termination of Employment Convention, 1982; <https://is.gd/XiQiwD>

- Factories must have culturally appropriate written grievance policies and procedures in place that protect employee privacy, protect against possible retribution, and provide multiple channels for reporting grievances so that workers are able to report unfair treatment to someone other than their supervisor.
- A discreet, effective complaint procedure should be in place for all workers. A trusted person, such as an appointed counselor, should be the administrator of the system. This person (or people) should be appropriately trained in responding to potentially sensitive grievances and experienced with cross-cultural communication. Ideally, the system should have both internal and external reporting channels to ensure anonymity and accountability. There should be suggestion boxes in private and secure locations that are easily accessed by the workers. Wherever possible, the facility may also provide a telephone hotline number or postal address for employees to report grievances.
- Reporting and feedback channels should account for language barriers and literacy levels.
- Factories' grievance policies and procedures must also include a system for resolving disputes in the workplace, e.g., a dispute resolution committee or workers' council that receives, investigates, and resolves workplace grievances. The council should have diverse representation across lines of gender, job function, and job level.
- The factory should use a clearly defined and documented system for resolving disputes in the workplace, whether between coworkers or between workers and supervisors.
- The factory must adopt and communicate a non-retaliation policy that guarantees that workers who report problems or abuses do not suffer negative consequences.
- There should be a set timeframe for company response (and resolution, if possible) to complaints.
- The person who makes the complaint should be kept informed at each step of the process.
- There should be an internal, confidential appeal procedure that workers can use if management does not adequately respond to their complaint.
- There should be an appeal procedure for workers who feel they have been unjustly warned or disciplined.

**IA** Factories must have clear and established employment policies ([see General Labor Practices](#)). These policies must be made publicly available to all workers and applied uniformly to all employees, including guidelines to prohibit the use of these employment processes in an inappropriate or coercive manner or as an unsanctioned form of discipline.

- Disciplinary policies must include an escalating series of verbal and written warnings before suspension or dismissal. Disciplinary measures taken must be documented in the worker's file and a copy of such warnings must be provided to the worker.

**IA+** Factory managers/supervisors must never use or condone coercive behavior, verbal abuse, or abusive disciplinary tactics or procedures. Threatening, either explicitly or implicitly, to withhold workers' fundamental rights, including wages, benefits, leave permission, access to food, services, etc., is considered coercive behavior.

- Access to food, water, toilets, medical care or health clinics, or other basic necessities will not be used as either reward or punishment.
- Employers will not unreasonably restrain the freedom of movement of workers, including movement in the canteen, during breaks, using toilets, accessing water, and accessing necessary medical attention.
- Managers should never use intimidation or mentally abuse workers, such as throwing objects at the ground in front of workers.
- Employees will not be threatened or intimidated in any manner or have the fear of threats or intimidation.

**IA+** Disciplinary measures must not include monetary fines. Tardiness should be deducted on a pro-rata basis.

- Managers must never threaten illegal or undue fines as a means of disciplining or influencing behavior.

**IA+** Security personnel must not administer disciplinary action against employees.

- Security must not have the right to discharge workers.
- The military must not be allowed to participate in disciplinary procedures.
- Security practices must be gender-appropriate and nonintrusive.

**IA+** Management will discipline (could include combinations of counseling, warnings, demotions, and termination) anyone (including managers or fellow workers) who engages in any physical, sexual, psychological, or verbal harassment or abuse.

**IA** Managers and Supervisors must receive supervisory skills training that builds their capacity to foster teamwork and effectively motivate co-workers while upholding core values of respect and fairness. Managers and Supervisors must be regularly trained in company procedures to ensure compliance and abuse prevention. Security staff, doctors, nurses, managers, and other key personnel (where relevant) should be regularly trained to recognize signs of gender-based violence and harassment and understand laws and organizational policies on human trafficking and sexual exploitation. Frontline employees should also receive instruction on their rights under national law, company practices and international standards.<sup>7</sup>



<sup>7</sup> UN High Commissioner for Human Rights Convention against Torture and Other Cruel, Inhuman or Degrading Treatment or Punishment, 1984, <https://www.ohchr.org/en/professionalinterest/pages/cat.aspx>; Universal Declaration of Human Rights, 1948, Articles 3 and 5, <https://www.un.org/en/universal-declaration-human-rights/>



- Policy and procedures should be present in employee handbooks and manuals, which should be made available in all languages used in the Factory.
- Grievance procedures should be included in the orientation for new and temporary hires and in periodic training for existing workers, supervisors, and managers.
- The factory should provide cross-cultural training to expatriate managers, supervisors, and workers.



**CI** Factories should effectively communicate disciplinary procedures to employees.

**Note:** Levi Strauss & Co. recognizes that different management techniques are used throughout the world. To protect the dignity of workers, the SCOC seeks to ensure that suppliers act reasonably in deciding the nature and the amount of discipline to apply in given circumstances.

## DISCIPLINARY PRACTICES Non-Compliances & Corrective Actions

Finding	Corrective Action	Recommended Timeline	Verification Method
<p><b>ZTV – Corporal Punishment:</b> Workers are physically punished, for example, they are asked to stand-up at the back of the production area for 1 hour if they arrive late to work.</p>	<p>The factory must discontinue the practice immediately. The factory must provide credible supervisory skills training and may be supported by a local NGO. The factory must monitor for change in behavior, and if necessary, terminate the employment of abusive personnel.</p>	<p>Immediately discontinue practice / schedule training within 3 weeks</p>	
<p><b>ZTV – Sexual Harassment:</b> One male supervisor is always touching the female workers, and they are obviously made uncomfortable by his actions.</p>	<p>The management must intervene to stop the behavior immediately. The factory leadership must conduct an investigation into the incident in alignment with investigation procedures outlined in the policy and implement relevant disciplinary action(s). The factory must ensure that management also effectively follows up on the outcomes of the investigation. In addition, the factory leadership must provide credible supervisory skills training and create a rights-respecting work environment that is designed to empower workers to speak up.  (Note: Policies clearly defining and prohibiting sexual harassment must also be in writing and posted; <a href="#">see General Labor Practices</a>. In addition, there must be effective grievance procedures for workers to use in reporting any unfair/inappropriate treatment.)</p>	<p>Immediately discontinue practice / 3 weeks to schedule training</p>	

Finding	Corrective Action	Recommended Timeline	Verification Method
<p><b>IA+ – Coercion/Verbal Abuse:</b> One supervisor shout at workers whenever they make mistakes or if they are unwilling to stay and work overtime.</p>	<p>The supervisor must stop the behavior immediately. The factory leadership must conduct an investigation into the incident in alignment with the investigation procedures outlined in the policy and implement relevant disciplinary action(s). The factory must ensure that management also effectively follows up on the outcomes of the investigation. In addition, the factory leadership must provide credible supervisory skills training and create a rights-respecting work environment that is designed to empower workers to speak up.</p> <p>(Note: Policies clearly defining and prohibiting coercive behavior and abusive disciplinary tactics must also be in writing and posted; <a href="#">see General Labor Practices</a>. In addition, there must be effective grievance procedures for workers to use in reporting any unfair/ inappropriate treatment.)</p>	Immediately discontinue practice / 3 weeks to schedule training	
<p><b>IA – Disciplinary Practices:</b> One worker in the sewing department was fired for a small mistake, even though this was the first time that worker had ever done anything wrong. One supervisor gives workers a written warning the first time they are tardy even though workers in other departments can be tardy two times before getting a written warning.</p>	<p>Supervisors and workers must be educated on the disciplinary procedures, and they must be carried out consistently in the factory. The procedures must include an escalating series of verbal and written warnings prior to suspension or dismissal.</p> <p>(Note: Disciplinary procedures must also be in writing and posted; <a href="#">see General Labor Practices</a>.)</p>	Immediately discontinue practice / 3 weeks to hold training sessions	
<p><b>IA – Disciplinary Practices:</b> Because a worker failed to inform her supervisor that she would not report for work that day, the supervisor would not allow the worker to perform OT for 1 week.</p>	<p>Supervisors and workers must be educated on the disciplinary procedures, and they must be carried out consistently in the factory. The procedures must include an escalating series of verbal and written warnings prior to suspension or dismissal.</p> <p>(Note: Disciplinary procedures must also be in writing and posted; <a href="#">see General Labor Practices</a>.)</p>	Immediately discontinue practice / 3 weeks to hold training sessions	

Finding	Corrective Action	Recommended Timeline	Verification Method
<p><b>IA – Grievance System:</b> Factory management has established that workers report grievances to their supervisors. The workers say that the only way to complain about verbal abuse from a supervisor is to complain to the supervisor himself and they are afraid they will be fired if they complain.</p>	<p>The factory should develop a variety of accessible communication channels (internally and externally managed) such as through anonymous suggestion boxes, reporting to upper management or HR personnel, hotlines, etc. that protect privacy, protect against retribution and allow reporting to someone other than supervisors. The factory should ensure all those charged with responding to grievances are appropriately trained in handling potentially sensitive grievances, as well as cross-cultural communication.</p> <p>The system should set out a timeframe for response and resolution, keep the complainant informed throughout the process, and have a method for appeal or escalation if the complainant is not satisfied with the outcome.</p> <p>The new procedures should be communicated to supervisors and workers. Further, the factory leadership must seek to create an enabling environment that will allow the grievance process to function effectively (i.e., a rights-respecting work environment that is designed to empower workers to speak up).</p> <p>(Note: Grievance procedures, including management follow-up activities, must also be in writing and posted; <a href="#">see General Labor Practices</a>.)</p>	2 weeks	
<p><b>C1 – Worker Awareness:</b> Workers are unaware of disciplinary procedures because of the high rate of illiteracy. The facility has posted the procedures, but the workers are not able to read them.</p>	<p>The new hire orientation and factory policy training should include verbal explanations or graphics for those employees who are not able to read. (Note: Disciplinary procedures should also be in writing and posted; <a href="#">see General Labor Practices</a>.)</p>	4 weeks	

## LEGAL REQUIREMENTS

We expect our business partners to be law-abiding as individuals and to comply with legal requirements relevant to the conduct of all their businesses.

### Requirements



**ZTV** Factories must observe and be in compliance with all legal judgments against them.

**ZTV** Factories must observe and be in compliance with Rules of Origin laws and regulations.

**IA** Factories must understand Country of Origin requirements to ensure they are in compliance.

**Note:** The fact that there may be lawsuits against a particular factory or member of management does not mean that the factory is operating illegally. If the lawsuit is being addressed through the established legal channels of the country, there is no violation of Levi Strauss & Co.'s SCOC.

## LEGAL REQUIREMENTS Non-Compliances & Corrective Actions

Finding	Corrective Action	Recommended Timeline	Verification Method
<b>ZTV – Legal Requirements:</b> : The owner of the facility was convicted of tax evasion and has ignored the judgment	The factory owner must comply with the judgment or Levi Strauss & Co. will consider exiting the factory.	Immediately	
<b>IA – Rules of Origin:</b> The factory management does not know the Country-of-Origin laws.	Logistics or customs staff must be trained on the requirements of Country of Origin.	2 weeks	





## ETHICAL STANDARDS

We will seek to identify and utilize business partners who aspire, as individuals and in the conduct of all their businesses, to a set of ethical standards not incompatible with our own.

### Requirements

- ZTV** Factories must provide access to workers, records, and factory work areas, and they must be cooperative and transparent during the SCOC assessment process.
- ZTV** Factories must not engage in corrupt or unethical practices, such as paying bribes in exchange for jobs, preferential treatment, etc.
- ZTV** Unauthorized subcontracting is prohibited.
- ZTV** Factories must maintain only one set of complete and accurate working-hour and payroll documents and records that represent true work conditions.
- ZTV** Factories must never present or require workers with blank papers/resignation letters to sign.
- IA+** Factories must not engage in practices, such as annually firing and re-hiring workers or unreasonably designating workers as probationary, designed to circumvent national or local wage, benefit, or other labor laws.
- IA** The supplier shall conduct an internal audit every 6 months.
- IA** The supplier shall review and update legal requirements on a regular basis, at the minimum every quarter.
- CI** The supplier shall identify, track, and update all direct/indirect materials/sundries/subcontracted suppliers on a regular basis, at the minimum every quarterly or when there is any change.

## ETHICAL STANDARDS Non-Compliances & Corrective Actions

Finding	Corrective Action	Recommended Timeline	Verification Method
<b>ZTV – Bribery:</b> Supervisors are given bribes so that some workers gain preferential treatment for shifts or access to medical care, etc.	The factory must immediately discontinue the practice.	Immediately	
<b>ZTV – Subcontracting:</b> When production levels are high, work is subcontracted out to a nearby factory. LS&Co. has not been informed of the use of the stated factory.	Work at the nearby factory must immediately be terminated and production removed.	Immediately	
<b>ZTV – Record Keeping :</b> There are 2 sets of time records. One set was created by the factory to hide excessive OT. The payroll records reflect overtime payments, but the payments are not actually given to workers. (i.e. No overtime pay). Pay slips show payments reflective of time worked (without overtime) and the workers confirm the practice.	Factory must discontinue this unethical practice immediately and use only one set of records that represents true work conditions.	Immediately	
<b>ZTV – Access: :</b> Workers were forced to sign a blank paper when they were hired, so that the factory can make it look like they resigned even if they are fired.	Cease the practice and dispose of any blank papers still in factory’s possession.	Immediately	
<b>ZTV – Ethical Practices: :</b> One worker in the sewing department was fired for a small mistake, even though this was the first time that worker had ever done anything wrong. One supervisor gives workers a written warning the first time they are tardy even though workers in other departments can be tardy two times before getting a written warning.	Supervisors and workers must be educated on the disciplinary procedures, and they must be carried out consistently in the factory. The procedures must include an escalating series of verbal and written warnings prior to suspension or dismissal. (Note: Disciplinary procedures must also be in writing and posted; <a href="#">see General Labor Practices.</a> )	Immediately	

Finding	Corrective Action	Recommended Timeline	Verification Method
<p><b>IA – Ethical Practices :</b> In “X” country, workers with two year’s seniority are entitled to receive an extra week of annual vacation, but the factory hires and fires workers each year so that the factory does not have to give them an extra week’s vacation.</p>	<p>Develop and implement new policies that seek to foster a long-term employee relationship with the factory, which also will enhance product quality and improve the factory’s bottom line. Educate supervisors and workers on these new policies.</p>	<p>Immediately cease practice/ 2 weeks for policies</p>	

## WORKING HOURS

**While permitting flexibility in scheduling, we will identify local legal limits on work hours and seek business partners who do not exceed them except for appropriately compensated and permissible voluntary overtime. While we favor partners who utilize less than sixty-hour work weeks, we will not use contractors who, on a regular basis, require in excess of a sixty-hour week. Employees must be allowed at least one day off in seven.**

### Requirements

- ZTV** Overtime hours must not regularly exceed four (4) hours per day for more than three (3) months within a 12-month period. In cases where local law permits more than four (4) overtime hours per day, this legislation will apply.
- IA+** Overtime hours must not exceed 60 hours per month. Where a country’s legal code requirements are more stringent on overtime hours, the legal requirements must be met.
- IA+** Factories must record all employee working hours completely and accurately.
- IA** Overtime hours must not exceed 12 hours per week and 48 hours per month. Where a country’s legal code requirements are more stringent on overtime hours, the legal requirements must be met.
- IA** The total regular working hours must not exceed 48 hours per week. Where a country’s legal code specifies the regular workday, workweek, rest days, and/or holidays, the factory’s schedules must be in compliance with the law.
- IA** Employees must have one day off in seven; they may work on their rest day but no more than once in every two weeks and no more than eight consecutive weeks per year. SCOC prefers that employees not work on their rest days.<sup>8</sup>
- IA** Time records for all workers must be available for review. Employees must maintain their own time records, i.e., punch in and out themselves.
- IA** Factories should have a working time clock that employees use to record their hours, both regular and overtime.

<sup>8</sup> ILO Weekly Rest (Industry) Convention, 1921, <https://is.gd/dUBUf8> and Universal Declaration of Human Rights, 1948, <http://www.un.org/Over-view/rights.html>



**WORKING HOURS**  
**Non-Compliances & Corrective Actions**

Finding	Corrective Action	Recommended Timeline	Verification Method
<b>IA – Working Hours:</b> Total working hours for a week is 72 hours and has been so continuously for the last 4 months.	The factory must submit a plan to reduce hours, with the goal of working less than 60 hours a week. (Note: Overtime must be voluntary and workers able to take one day off per week.)	2 weeks for the plan / 8 weeks for compliance	
<b>IA – Breaks :</b> In “X” country, workers must be given two morning breaks. Workers are only given one morning break, and they are expected to work through the second break.	Factory must provide the employees with the legally required number of breaks. (Relevant laws must also be posted; <a href="#">see General Labor Practices.</a> )	2 weeks for the plan / 8 weeks for compliance	
<b>IA – 7th Day Rest:</b> At “Y” factory, workers have Sundays off, but the time records reflect that some workers work every Sunday.	Develop a work schedule that limits overtime and does not encourage employees to work on their rest days. Employees must be educated on health/ safety dangers of excessive working excessive overtime. (Note: Overtime must be voluntary and working hours in general less than 60 hours per week.)	2 weeks for the plan / 8 weeks for compliance	
<b>IA+ – Record Keeping:</b> A factory does not have time records of all workers accessible. Workers are employed through subcontractor and the subcontractor was in possession of the records.	Time records for all workers must be available for review. (Note: Refusal to provide SCOC assessors with access to records is a different violation - <a href="#">see Ethical Standards</a> above).	1 week	
<b>IA+ – Record Keeping:</b> Workers are not allowed to punch in for overtime until after they have met their quota for the day.	Remove the no payment policy and suggest using positive means (such as bonuses) to encourage production. (Note: Separate records to cover up excessive overtime is a different violation; <a href="#">see Ethical Practices</a> above.)	Immediately	
<b>CI – Working Hours:</b> The factory does not have an automatic time clock or swipe system.	The factory should install an automatic time recording system and have employees record their own hours for both regular and overtime work. This helps to ensure accurate and complete records of working hours. (Note: Separate records to cover up excessive overtime is a different violation; <a href="#">see Ethical Practices</a> above.)	2 weeks to engage process / 8 weeks to complete	

**WAGES AND BENEFITS**

**We will only do business with partners who provide wages and benefits that comply with any applicable law and match the prevailing local manufacturing or finishing industry practices.**







**Requirements**











- ZTV** Where a country’s legal code specifies legal minimum wages and allowances, factories must be in compliance with the law with respect to all workers, including employees paid on a piece rate.  
Note: This requirement can be rated at less critical risk ratings (IA+) when it is not a systemic failure and is affecting a small number of employees (<3% workforce). In this regard, factories shall take action to entitle full wages to all employees immediately, but no later than 6 months.
- IA+** Where a country’s legal code specifies an overtime rate or an overtime premium, factories must be in compliance with the law.
- IA+** Workers must be paid the legal rate for all overtime hours worked.
- IA+** Requiring overtime where workers are unable to leave the work premises or are in any way forced to accept it (through abuse, threats of dismissal, or other) is not allowed.
- IA+** Where a country’s legal code specifies that workers must receive certain benefits (such as retirement benefits, health insurance, workman’s compensation, etc.), factories must be in compliance with the law.
- IA+** Where a country’s legal code specifies that women employees must be provided with maternity benefits, factories must be in compliance with the law.
- IA+** Where a country’s legal code specifies the time and/or manner of wage payments, factories must be in compliance with the law and follow any legal requirements in cases of wage delay (i.e., interest, etc.).<sup>9</sup>
- IA+** Payroll records for all workers, including those who resigned in the month, must be available for review.
- IA+** Factories must not deduct more from workers’ wages than is legally permitted.
- IA+** Factories must not deduct recruitment agency fees from workers’ wages.
- IA** Policies for the calculation of basic wages, overtime, bonuses, and payroll deductions should be the same for all employees, and measures should be taken to ensure that compensation policies and wage systems are transparent and that all workers understand these policies.

<sup>9</sup> Universal Declaration of Human Rights, 1948, <https://www.un.org/en/universal-declaration-human-rights/> and ILO Protection of Wages Convention, 1949, <https://is.gd/BG3E5w>

- IA** Factories must provide all benefits and bonuses in accordance with the law.
- IA** Factories must not deduct wages for tardiness that exceed the actual man-hour loss.
- IA** Factories must meet the legal requirements regarding wage payments.
- IA** Where the industry prevailing wage is greater than the minimum wage, the prevailing wage must be paid.
- IA** Work performed must be on the basis of recognized employment relationships with no use of labor only contracting or sub-contracting to avoid payment of benefits to workers or other obligations under labor or social security laws.
- IA** Factories must pay wages to all workers through bank transfer or other electronic means, i.e., a mobile money service provider.
- IA** Factories should provide workers with pay slips that show regular and overtime hours worked, regular and overtime rates and wages, bonuses, and deductions. Pay slips should be in a language workers understand.
- CI** Factory Managers/Supervisors should be trained in compensation procedures to ensure compliance and eliminate opportunities for abuse.
- CI** Factory workers should receive regular instruction on their rights under national law and company procedures for compensation. Where relevant, employees should also receive training on international standards and best practices.

### WAGES AND BENEFITS Non-Compliances & Corrective Actions

Finding	Corrective Action	Recommended Timeline	Verification Method
<b>ZTV – Minimum Wage:</b> In a country “X”, the minimum wage is set at 300 pesos per month (and no sub-minimum is allowed per law), but the factory only gives 250 pesos as a startup salary for the first 3 months of work.	Wage payment must meet legal requirements. Arrears must be paid if payments have been less than required by law. (Relevant laws must also be posted; see General Labor Practices.)	Immediately adjust to meet legal requirement/1 week for plan	
<b>IA+ – Overtime Wages:</b> The legal requirement in computing OT for Sunday work is 2x the hourly wage, multiplied by total Sunday OT hours, but the factory only pays 1.5x multiplied by total Sunday OT hours.	OT payment must meet legal requirement. Arrears must be paid if payments have been less than required by law. (Relevant laws must also be posted; <a href="#">see General Labor Practices.</a> )	Immediately adjust to meet legal requirement / 1 week for plan	
<b>IA – Overtime Wages:</b> Workers are not paid for all overtime hours worked, because supervisors do not record the first hour of overtime.	All overtime hours worked must be paid, as well as any arrears due to workers for hours not paid.	Immediately correct practice / 2 weeks to revise system for recording hours worked	
<b>IA+ – Benefits:</b> Workers are not provided with medical insurance within three months of hire, as required by law.	Provide the required benefits and educate employees on new benefits. (Relevant laws must also be posted; <a href="#">see General Labor Practices.</a> )	1 week to apply for benefits / 4 weeks for education	
<b>IA – Payment of Wages:</b> There have been occasions when workers’ wage payments were delayed for 3 days. Per law, wage must be paid on the last Wednesday of the month.	The factory must meet legal requirements and improve the payment schedule to always pay wages on- time. (Relevant laws must also be posted; <a href="#">see General Labor Practices.</a> )	4 weeks	
<b>IA+ – Subcontractors:</b> The factory does not maintain payroll records of workers on site. Workers are employed through a subcontractor, and the records are maintained by the subcontractor.	The factory must have copies of all subcontractor wages paid. These must be available for review. (Note: Refusal to provide SCOC assessors with access to records is a different violation ( <a href="#">see Ethical Standards</a> above).	1 week	

Finding	Corrective Action	Recommended Timeline	Verification Method
<b>ZTV – Minimum Wage:</b> In some countries, the legal minimum wage is divided into a basic wage and cost of living allowance, overtime, social security computation is based on the basic wage.	Wage payment must meet legal requirements. (Note: Assessor to consult Sustainability Manager/other stakeholders on back-wages (arrears to be paid)).	Immediately adjust to meet legal requirement / 1 week for plan	 
<b>IA – Deductions:</b> The factory deducts money from workers as part of the workers' contribution to Social Security. The factory delays remitting the money to the bank or government agency.	The factory must ensure that the social security payments are remitted within the legal timeframe and pay any fines as per law.	1 week for plan / 1 month to remit payment and maintain current	
<b>IA+ – Benefits:</b> The factory is legally required to pay workers for the 13th (or 14th) month but only pay 50% of the amount.	Benefits must be paid as required by law. Arrears must be paid if necessary.	Immediately pay bonus / 1 week for plan	 
<b>IA – Deductions:</b> Review of company rules reveals that for 5 minutes of tardiness, 10% of the daily wage is deducted, 10 minutes is 15% and so on.	Review and change policy on so that wage deduction for tardiness is reasonable and not confiscatory and legal.	1 week to stop deductions / 3 weeks for communication	 
<b>CI – Pay Slips:</b> Workers sign the factory pay register, which shows only total wages for the month. Workers do not receive pay slips.	The factory must provide pay slips with complete payroll information, so that workers understand how their pay is calculated.	1 week to engage process / 8 weeks to complete	 
<b>CI – Worker Awareness:</b> Most of the workers are not aware of their wage composition, calculation and the benefits which are provided.	Provide education and include it in handbook/posters, and provide payroll slips to include the details of calculation. 80% of all workers interviewed should be aware of their benefits and understand how they are calculated.	4 weeks	

## GENERAL LABOR PRACTICES AND FREEDOM OF ASSOCIATION

We respect workers' rights to form and join organizations of their choice and to bargain collectively. We expect our suppliers to respect the right to free association and the right to organize and bargain collectively without unlawful interference. Business partners should ensure that workers who make such decisions or participate in such organizations are not the object of discrimination or punitive disciplinary actions and that the representatives of such organizations have access to their members under conditions established either by local laws or mutual agreement between the employer and the worker organizations.

### Requirements

#### Freedom of Association

**ZTV** Workers of all genders shall have the right to establish and join organizations of their own choosing, subject only to the rules of the organization concerned, without previous authorization. Factories must respect employee rights to freedom of association; they must not impose any punitive actions against workers in supporting union activities. Punitive actions include threatening, fining, suspending, or firing workers exercising their right to support union activities. Any action that suppresses freedom of association is prohibited to the fullest extent permitted under applicable local law and may be an act expressly identified as illegal in some countries' labor codes.<sup>10</sup>

Laws in different countries vary substantially regarding freedom of association. Most countries maintain procedural regulations regarding the actions of workers and employers. Some countries place substantial restrictions on workers' rights of association. The SCOC provision on free association neither permits nor requires LS&Co. or its business partners. To engage in unlawful activities to protect the rights of association. Nevertheless, where the right to freedom of association and collective bargaining is restricted under law, the supplier should not hinder any workers from joining or forming associations or pursuing the development of lawful parallel means for independent free association and bargaining. Subject to the following:

- The Factory must have a Freedom of Association (FOA) policy that is effectively and extensively communicated to all workers and management.
- Employers may not use intimidation, unreasonable searches, or police or military force to obstruct workers' right to freedom of association.
- Workers' organizations have the right to conduct their activities and elect their representatives without employer interference, such as the presence of factory management or factory designees at organizing meetings.

<sup>10</sup>ILO Freedom of Association and the Right to Organize, 1948; ILO Right to Organize and Collective Bargaining Convention 1949, ILO Collective Bargaining, Convention, 1981 <https://is.gd/QU58zV>

- All workers of all genders are free to meet and discuss workplace issues in the factory during their breaks and before and after work.
- Workers may communicate their concerns about factory practices to management, choose representatives to organize workers, inspect working conditions, engage in dialogue with factory management, and carry out other organizing activities that do not disrupt factory production.
- The employer shall not interfere with employees' right to freedom of association; the employer shall not control workers' organizations or favor one workers' organization over another.
- Employers are not required to take an active role in supporting workers' efforts to associate or organize, but employers must ensure that workers can exercise their right to organize in a climate free of violence, pressure, fear, and threats.
- Factory management shall not impede workers' right to peaceful organization by outsourcing work performed by union members. Shifting production from one site to another for the purpose of retaliating against workers who have formed—or are attempting to form—a union is not acceptable.
- Employers may not offer or use severance pay as a means of discouraging union activities. Unscheduled wage or benefit increases must be avoided while a union organizing campaign is in progress.
- When a union(s) exists at a factory, workers must receive copies of the collective bargaining agreement (CBA) at the time of hire or joining the union and whenever the CBA gets revised.

**IA+** Fixed term contracts or apprenticeship schemes where there is no real intent to impart skills or train for regular employment must not be used to avoid payment of benefits to workers or other obligations under labor or social security laws.

**IA+** Where legally required, factories must have a written employment contract with every employee and must provide every employee with a signed copy of their contract. Employment contracts must be in a language that workers understand and must contain an accurate and complete summary of the terms of employment. If workers are illiterate, the supplier must explain terms to workers prior to signing a contract.

**IA** Trainees must have the same wages, benefits, and other conditions of employment as permanent employees after three months of employment, or earlier, as per law.

**IA** Temporary workers must have the same wages, benefits, and other conditions of employment as permanent employees after nine months, or earlier, as per law.

**IA** Factories should maintain a personnel file for each employee, whether direct or indirect, that contains appropriate employee records such as signed age verification documents, employment agreements, disciplinary notices, reference checks, and leave and benefit records.

**CI** Factories should retain files of dismissed employees onsite for three years or longer if legally required. Files should include a termination checklist for the recovery of company assets and the reason for dismissal.

### **General Labor Practices**

**ZTV:** The use of unauthorized homework in the production of any LS&Co. product is prohibited.

**IA** Strip searches or pat-downs are prohibited.

**IA** Factories are responsible for providing workers with all work tools, materials, badges, etc., free of charge.

**IA** Factories must have clear and established employment policies to guide recruiting, hiring, training, working hours, pregnancy and maternity accommodations, harassment/abuse, grievance, discipline, termination, promotion, diversity, and compensation procedures. These company policies must be made publicly available to all workers, in a language that they understand, and applied in a standardized fashion throughout the facility.







- All policies must be gender-sensitive, meaning that they proactively identify factors that impact women and men differently and seek to equalize them.
- Regulations must include the minimum working age, facility age-verification procedures, juvenile employment restrictions (if any), wages, regular and overtime hours and rates, benefits and deductions, vacation and sick leave (including the circumstances—such as family emergencies—under which employees may be granted permission to leave the factory without disciplinary penalty).

**IA** Factories must have clear policies on contractual terms, such as conversion from probation to full-time and other important milestones, to prevent any kind of exploitation of workers, including quid pro quo sexual favors. Where the local law leaves ambiguity for interpretation, factory management is responsible for effectively and extensively communicating the factory's policy to all levels of management and workers.

**CI** Factories should have accurate, complete, and reasonable internal rules and regulations, written in a language that workers understand and posted in a visible/accessible location. Regulations should include: the minimum working age, facility age-verification procedures, juvenile employment restrictions, wages, regular and overtime hours and rates, benefits and deductions, vacation and sick leave (including the circumstances—such as family emergencies—under which employees may be granted permission to leave the factory without disciplinary penalty), discipline and termination procedures, grievance procedures, and harassment/abuse policies.

- CI** Factories should effectively communicate internal rules and regulations to employees.
- CI** Factories should post national or local labor laws, written in language workers understand, in a visible and accessible location where workers can read them. Posted laws should cover the minimum working age, minimum wage and legal overtime rates, benefits, work hours, freedom of association, and harassment/abuse (if available).
- CI** Factory Managers/Supervisors should be trained in company procedures to ensure compliance and eliminate opportunities for abuse. This training should be conducted through onboarding/orientation and periodic refresher training.
- CI** Factory workers should receive regular instruction on their rights under national law and company procedures. Where relevant, employees should also receive training on international standards and best practices.
- CI** As part of the termination process, exit interviews should be conducted with workers who choose to leave voluntarily to ensure that the factory is aware of cases where workers may have experienced harassment and leave rather than engage in a documented grievance process. If these findings surface, the factory should further investigate incidents of harassment to ensure it isn't happening to other employees and to pursue appropriate discipline/remediation with the perpetrator(s). The results of these exit interviews should be retained in employee files on site for 3 years.

## GENERAL LABOR PRACTICES AND FREEDOM OF ASSOCIATION Non-Compliances & Corrective Actions

Finding	Corrective Action	Timeline	Verification Method
<b>ZTV – Unions:</b> A factory imposes fines, suspension, etc. to any worker supporting actions to form a labor union.	The factory must stop the practice of imposing fines, etc. Instead, the factory must remain neutral and initiate dialogue with workers and respect their freedom of association.	Immediately	
<b>IA – Employment Policies:</b> A factory does not have clearly documented and established policies that are well-understood by workers and Managers/Supervisors alike. There is no consistency in implementation or enforcement, so workers are vulnerable to subjective decisions by those above them.	The factory must immediately commence documenting a comprehensive set of employment policies to guide recruiting, hiring, training, working hours, harassment/abuse, grievance, discipline, termination, promotion, diversity, and compensation procedures. These company policies must be made publicly available to all workers, in a language that they understand, and applied in a standardized fashion throughout the facility.	2 weeks to create a plan / 8 weeks to document policies and schedule trainings for workers, managers/ Supervisors	
<b>IA – Collective Agreements:</b> In a unionized plant, the factory and union have agreed on a collective agreement that is good for 3 years. However, after the 1st year, the factory did not want to honor some portions of the agreement.	Terms of Collective bargaining must be honored. The factory must initiate dialogue with the union to resolve the issue.	2 weeks to start the dialogue	
<b>IA – Worker Probation Period:</b> In “X” country, the probation period cannot last more than three months, but factory employees tell assessors they have been in probationary status for five months.	The employees’ status must be upgraded. Communicate the new policy to the supervisors and workers. Ensure compliance in all other terms of employment.	2 weeks	
<b>IA – Classification of Workers:</b> The workers have been classified as trainees for over a year, even though they do the same work as regular workers.	The employees’ status must be upgraded. Change the policy and communicate the change to the employees.	2 weeks	
<b>IA – Classification of Workers:</b> Eighty-five percent of workers are temporary workers, not permanent.	The employees’ status must be upgraded according to the amount of time they have been working. Change the policy and communicate the change to the workers.	2 weeks	

Finding	Corrective Action	Recommended Timeline	Verification Method
<p><b>IA – Deposit for Tools:</b></p> <p>The factory requires workers to deposit money for scissors (Factory’s reason: Tools will be lost or not returned after signing for them) and fines workers for broken scissors.</p>	<p>The factory must ensure: a policy and plan to pay back any deposits and be able to provide proof that the money was returned to workers.</p> <p>Change the practice (i.e., provide tools for the workers; develop incentive system for minimizing tool loss).</p>	Immediately stop the practice / 2 weeks to implement new policy	
<p><b>IA+ – Legal Documentation:</b></p> <p>The factory does not have documentation to show proof of worker employment. Where legally required, workers do not have written employment contracts.</p>	<p>If legally required, the factory must provide employment contracts to workers and properly maintain them. Processing time for new employees must not exceed 4 weeks. (Copies must also be kept in employee personnel files; see below. Also, factories must not use annually renewed employment agreements to evade labor laws; <a href="#">see Ethical Standards.</a>)</p>	4 weeks	
<p><b>CI – Rules and Regulations:</b></p> <p>A factory, newly set-up, does not have any written internal company rules and regulations, but actions are based on the labor code.</p>	<p>The factory should establish internal rules and regulations, post the regulations in the language of the workers and visible to all workers, and provide education to workers/ management.</p>	8 weeks	
<p><b>CI – Worker Awareness:</b></p> <p>Some workers were completely unaware of the company rules and regulations.</p>	<p>The workers should be educated on the company rules and regulation. (Note: Rules and regulations must also be in writing and posted; see above.)</p>	4 weeks to hold training sessions	
<p><b>CI – Labor Law Posting :</b></p> <p>There are no labor laws posted in the factory.</p>	<p>The factory should post relevant laws visible to all workers.</p>	4 weeks to complete	
<p><b>CI – Worker Documentation:</b></p> <p>The factory maintains personnel files only for permanent workers. The factory manager says there are no personnel files for workers employed through the subcontractor. Files for permanent employees do not contain employment contracts or age- verification documents.</p>	<p>The factory should maintain all legally required documentation such as employment contracts and proof of age documentation for temporary, as well as permanent workers. The records should be updated regularly.</p> <p>(Note: records must be copies, not originals; <a href="#">see Prison, Forced or Trafficked Labor.</a>)</p>	8 weeks	
<p><b>CI – Worker Documentation:</b></p> <p>The factory does not keep records for dismissed employees.</p>	<p>All paperwork related to dismissed employees (hiring documentation, disciplinary action, etc.) should be kept for 3 years.</p>	8 weeks	

## DISCRIMINATION

While we recognize and respect cultural differences, we believe that workers should be employed on the basis of their ability to do the job rather than on the basis of personal characteristics or beliefs. We will favor business partners who share this value.

### Requirements

- IA+** Pregnancy tests or the use of contraception shall not be used as a condition of hiring or continued employment. Factories that are not legally required to do so must not require female applicants, contract workers, or employees to be tested for pregnancy. Pregnancy testing must be voluntary, not mandatory. Mandatory pregnancy testing (if not a legal requirement) is prohibited.<sup>13</sup>
- IA+** It is prohibited for factories to ask female applicants about their pregnancy status; it is prohibited to consider pregnancy as a negative factor in factory hiring, salary, benefits, advancement, discipline, termination, or retirement practices.
- IA** Factories must have clear and established company policies ([see General Labor Practices section](#)). These company policies must be made publicly available to all workers, in a language that they understand, and applied in a standardized fashion throughout the facility. Discrimination in any form is prohibited.<sup>11</sup>
  - All policies must prohibit discrimination based on age, caste, color, disability, gender, gender identity & expression, sexual orientation, health status (including HIV, hepatitis B), marital status, pregnancy status, parenthood, nationality, social, national, or ethnic. Origin, migrant worker status, political opinion, race, religion, union affiliation, or any other characteristic protected by national, state, or local laws.
  - The diversity policy must affirm high-level support and direct top-level policies for gender equality and human rights.
  - Relevant policies must establish company-wide goals and targets for gender equality, including gender-sensitive recruitment and retention practices, and must proactively recruit and appoint women to managerial and executive positions.
- IA** Workers should have equal access to opportunities in all aspects of work training and personal and professional development, regardless of a worker’s gender identity. Factories must promote education, training, and professional development for women<sup>12</sup>, including:
  - Investing in workplace policies and programs that open avenues for the advancement of women at all levels and across all business areas and encourage women to enter nontraditional job fields.
  - Encouraging equal access to all company-supported education and training programs, including literacy classes and vocational and information technology training.
  - Encourage equal opportunities for formal and informal networking and mentoring.

<sup>11</sup> ILO Equal Remuneration Convention, 1951: <https://is.gd/8edWYb>; ILO Discrimination (Employment and Occupation) Convention, 1958: <https://is.gd/HZyuY1> ; ILO Migrant Workers (Supplementary) Convention, 1975: <https://is.gd/aZ1dUZ> ; Termination of Employment Convention, 1982: <https://is.gd/XiQjwD> ; Universal Declaration of Human Rights, 1948: <https://www.un.org/en/universal-declaration-human-rights/>

<sup>12</sup> UN Women’s Empowerment Principles, 2016: <https://www.weps.org/principle/treat-all-women-and-men-fairly-work-without-discrimination>

<sup>13</sup> ILO Maternity Protection Convention (Revised), 1952: <https://is.gd/aYOeOk>

**IA+** On-site facilities must be offered to female workers who are pregnant or nursing. Pregnant or nursing workers shall be protected against threats of dismissal or any other employment decision that negatively affects their employment status in order to prevent them from getting married or becoming pregnant.

**IA** Factories must meet any legal and SCOC conditions on the working environment for women and pregnant, post-partum, and lactating women. Pregnant workers must not perform work that is prejudicial or poses documented risk to the health of the mother or her child.

**IA** Factories must make reasonable accommodations in job conditions for pregnant women (such as job reassignments to non-hazardous or lighter work, provision of seating, extended breaks, etc.).

**CI** Factories must set contextually appropriate gender promotion targets and hiring ratios to help incentivize increased opportunities for women. Factories should establish formal promotion procedures to ensure that they can promote employees based on objective criteria.

**CI** It is prohibited for factories to shame, harass, or discriminate against female workers during their periods of menstruation. Offering information, goods, and services to women workers regarding menstrual hygiene (free or subsidized menstrual pads and pain medicine for menstrual cramping) is encouraged.

**CI** Factories should ensure that the reproductive rights of female workers are respected, which includes ensuring access to family planning products and services and care relating to pregnancy and maternity leave. Feminine hygiene products shall be made available to female workers.



**Note:** Levi Strauss & Co. maintains business partnerships in all parts of the world, and cultural practices and traditions differ in many of these places. Levi Strauss & Co. also maintains a global commitment to ensure that workers producing our products be treated solely on the basis of the ability to perform the job effectively.

As a result, the SCOC favors business partners who make employment decisions based solely on an individual's ability to perform his or her duties.

All the terms and conditions of employment in a facility producing goods for Levi Strauss and Co. are subject to this provision. This SCOC provision seeks to ensure equality of treatment and opportunity, but it does not mandate, for example, that all workforces be evenly divided between men and women.

## DISCRIMINATION Non-Compliances & Corrective Actions

Finding	Corrective Action	Recommended Timeline	Verification Method
<p><b>IA - Discrimination:</b> The factory posted a vacancy opening at the facility gate and it reads, "Wanted: Male sewer, Catholic, Single".</p>	<p>The factory must remove discriminatory requirements for recruitment and hiring</p> <p>The factory must establish a policy on hiring that prohibits discrimination. Communicate the requirements to relevant HR and management staff.</p>	1 week	
<p><b>IA+ - Pregnancy Testing:</b> As part of the pre-employment requirements, the factory requires the female workers to submit a medical exam which includes pregnancy testing.</p>	<p>The factory must remove discriminatory requirements for recruitment and hiring – i.e., the factory must not inquire about or conduct testing related to marital status/plans, pregnancy or parenthood status. The factory must establish a policy on hiring that prohibits discrimination. Communicate the requirements to relevant HR and management staff.</p>	Immediately discontinue mandatory testing / 2 weeks for worker education	
<p><b>IA+ - Pregnancy Testing:</b> Female workers are asked if they are pregnant, or they are required to submit to mandatory pregnancy testing. If pregnant, the women are not hired.</p>	<p>The factory must remove discriminatory requirements for recruitment and hire.</p> <p>The factory must establish a policy on hiring that prohibits discrimination. Communicate the requirements to relevant HR and management staff.</p>	Immediately discontinue questioning	
<p><b>IA - Discrimination:</b> On the workers' labor contracts, a clause is included that says that the workers will "commit not to get pregnant or marry in the first year of employment".</p>	<p>The factory must remove pregnancy-related or marriage-related discriminatory requirements for recruitment and hire.</p> <p>The factory must establish a policy on hiring that prohibits discrimination. Communicate the requirements to relevant HR and management staff.</p>	1 week for plan / 4 weeks to comply	
<p><b>IA - Discrimination:</b> In country "X", pregnant women are not legally allowed to perform overtime. However, pregnant women ask the factory for permission to work overtime so that they are able to earn more money. The factory allows the women to work overtime.</p>	<p>The factory must meet the legal requirements. The factory must communicate with identified workers regarding legal requirements that prohibit the overtime work which they seek and make clear potential health risks of overtime for a pregnant worker.</p>	Immediately	

Finding	Corrective Action	Recommended Timeline	Verification Method
<b>IA+ – Pregnant Workers:</b> Women returning from maternity leave are treated as new employees and paid probationary wages for the first three months.	The factory must establish a policy on hiring that prohibits discrimination and ensures women who return from maternity leave return with full pay and with no changes to contract status. The factory must communicate the requirements to relevant HR and management staff.	1 week for plan / 2 weeks to comply	
<b>IA+ – Pregnant Workers :</b> During worker interviews, female workers say that factory does not give pregnant women lighter work.	The factory policy must be revised or established to include protections for pregnant workers. The factory must provide “light” work for pregnant workers.	1 week for plan / 2 weeks to comply	
<b>IA – Discrimination:</b> A qualified female worker is not given a promotion because management feels that she will not be a good leader and thinks that because she has children, she will not be able to dedicate adequate time to her work.	The factory must establish a policy on promotion that prohibits discrimination and communicate the requirements to relevant HR and management staff. The factory must monitor diversity of promotions granted to ensure that they are making progress toward achieving targets related to diversity in management roles.	1 week for plan; 4 weeks to comply	

## COMMUNITY INVOLVEMENT

We will favor business partners who share our commitment to improving community conditions.

### Requirements

**CI** The SCOC encourages factories to contribute to the betterment of the community in which they are operating.

**Note:** Community involvement is defined as “the good management of a company’s relationships with its stakeholders”. LS&Co. considers how its business affects the communities in which we produce and sell our products.

Many forms of community involvement exist, and LS&Co. and the Levi Strauss Foundation enable positive change in communities through grants to “not-for-profit” organizations (charities, non-governmental organizations, associations) and by encouraging employees to donate time to meet the needs of their community by helping schools, hospitals, the Red Cross and more. Support is provided by dollars, in product, or by allowing employees to use company time for community activities.

Because of the emphasis on community involvement, it is important to LS&Co. that its suppliers contribute to the enhancement of their communities.



## FOREIGN MIGRANT WORKERS

The purpose of this section is to define the minimum requirements regarding Foreign Migrant Workers from hiring through the end of employment.

This guideline is intended to:

- Enable employers to adhere to requirements and best practices in the employment of Foreign Migrant Workers and
- Inform Foreign Migrant Workers of their conditions of employment as well as their rights and responsibilities.

This guideline is a part of the Sustainability Guidebook, so all the requirements defined in the Guidebook, i.e., child labor, freedom of association, forced labor, trafficked labor, disciplinary practices, health & safety, and so on, shall equally be followed.

A Foreign Migrant Worker is:

- A Foreign National employed in accordance with the requirements of the country of employment;
- For whom all administrative clearances, either locally and/or in the country of origin of the Foreign Migrant Worker, have been obtained by and through his employer; and
- Is employed under a contract of employment in the country of employment according to the statutory and regulatory requirements governing such contracts.

### Requirements

#### General

- IA** All applicable legal requirements for both the country of origin and the country of employment shall be followed.
- IA** Sustainability Guidebook guidelines shall be followed if stricter than legal requirements, no matter the issue.

#### Recruitment

- ZTV** No recruitment fee(s) shall be charged to any foreign migrant worker. Any commissions and other fees in connection with the employment of migrant workers must be covered by the employer.
- ZTV** No documentation fees (such as passport, visa) shall be charged to or withheld from any foreign migrant worker.
- ZTV** Workers shall not be required to make deposits and/ or financial guarantees, and their identity documents (such as passports, identity cards, etc.) shall not be retained by the employer. The practice of deposits (money/original identification) may prevent workers from freely ending their

employment (within the legal context). This violation occurs most with a migrant labor force.

- IA+** Employers shall sign a contract with the recruitment agencies with which they are working to describe all requirements defined in this guideline as well as any applicable legal requirements that are stricter than the guidelines. Migrant workers shall have exactly the same entitlements as local employees.
- IA** Recruitment practices shall be in compliance with the Sustainability Guidebook requirements as well as all legal requirements.
- IA** Recruitment shall be made via legally authorized recruitment bodies and/or by employers directly, if permitted by law. The recruitment of a Foreign Migrant Worker by an employer may be subject to fulfilling compulsory procedures and conditions.
- IA** Employer shall provide a list of the recruitment agencies with which they are working. This list must provide recruitment agency details, i.e., country, address, nationality that they provide service for, info for sub- recruitment agency that they are working with (such as coverage area, etc.)
- IA** Employers shall ensure the requirements, as well as the consequences for failing to adhere to the requirements, are well communicated to recruitment agencies. Copies of contracts shall be kept by the employer for at least five (5) years or as required by the law, whichever is longer.
- IA** Where recruitment advertisements are used, they shall include the statement of “NO RECRUITMENT FEE” prominently displayed and must include the employer’s contact details for complaints/communication in case of such requests.
- IA** In case no recruitment advertisement is used, recruitment agencies shall announce LS&Co.’s “NO RECRUITMENT FEE” policy explicitly by posters, etc.
- IA** Recruitment agencies must follow the same principles described in this procedure for any sub-recruitment agencies with which they work.
- IA** Where required, the employer must ensure that a recruited person has a medical examination in accordance with the provisions of the laws of the country of origin and ensuring data confidentiality.

**IA** Employer must perform task tests to determine the ability of employees in the country of origin.

**CI** Copies of all advertisements/announcements shall be kept by employers for at least five (5) years, or as required by law, whichever period is longer.

### **Contract of Employment**

**IA** An employer shall strictly comply with labor laws with regard to terms and conditions included in the individual contract of employment of the country of employment.

**IA** The terms and conditions of employment provided to foreign migrant workers shall be no less favorable than those provided to nationals.

**IA** Contracts must be prepared in 3 languages (English, the language of the employee, and the language of the country of employment). Employer shall be responsible for any deviation in translations. It must be stated that if there is a conflict between versions, the language of the contract signed by the worker will prevail.

**IA** The migrant worker shall sign only one contract of employment with the employer at the time of hire, though the migrant worker and the employer may subsequently modify the contract in writing.

**IA** The contract of employment must contain at least (but not limited to) the following information:

- The name and address of the employer
- The name of the worker, his/her address and all other particulars necessary for his or her identification
- The nature of the work and the place(s) where it is to be performed
- The duration of the employment
- The duration and conditions of probation (probation period must not be more than 3 months and/or requirements defined by country of employment, whichever is less)
- Normal working hours, shift system, etc., as applicable
- The rate of wages and other remuneration (for normal hours of work, overtime, night work, public holidays in accordance with country of employment standards) and methods of calculation thereof, the pay period and manner of payment of wages and other remuneration
- Any legally required deductions to be taken from wages (i.e. social security, income tax etc.) in the country of employment
- Bonuses and allowances, as applicable

- The right to repatriation at the employer's expense on termination of the contract
- Grounds on which a contract may be terminated (prior notice must not be more than 2 months for termination unless local law provides otherwise)
- Medical examination requirements (as determined by the country of employment)
- Security conditions (e.g., curfews)
- Medical coverage and its terms & conditions
- Conditions regarding lodging and meals (the amount for lodging and meals must not be more than 15% of the minimum wage defined by the country of employment)
- Air Passage: A Round trip to the home country (or point of origin) shall be provided by the employer with no recharge back to employees. In all conditions except the termination of contract by an employee, the employer shall provide return ticket
- Terms and Conditions of vacation, annual leave, and/or sick/medical leaves (which cannot be less than required by local law)
- Details of money transfer alternatives in the country of employment
- Details of embassy/consulate in the country of employment for the nationality of foreign migrant workers
- Details of labor bureau offices, migrant worker desk numbers, hot hotlines (if applicable) in the country of employment

**IA** The contract must entitle either party to terminate the contract on giving due notice which is reasonable in length and not contrary to the interests of the worker (not more than 2 months, unless local law requires otherwise).

### **Remuneration and Benefits**

**ZTV** All migrant workers must be paid NOT less than the minimum wages stated by the labor laws applicable to migrant workers and receive all the applicable benefits outlined for migrant workers.

**IA** The remuneration to foreign migrant workers must be no less favorable than that provided to nationals.

**IA** No migrant worker shall be paid less than the minimum wage applicable to employees who are legal residents of the country of employment. Any increase in minimum wage in the country of employment shall be applicable to migrant workers. Such increases cannot be accounted for through the substitution of lodging and/or meals provided to employees.

**IA** If an employee decides to renew the employment contract without going back to the country of origin, then the employee must be eligible for reimbursement of the round trip air at the existing market rate.

**Communication**

- IA** The employers must ensure proper communication between management and migrant workers.
- IA** The employer shall appoint a facilitator who speaks the language of both the migrant workers and the employer.
- CI** Employer representatives should meet each nationality with the facilitator regularly to ensure the concerns are communicated appropriately to the top management. Records of such meetings should be kept and made available for review for a period of five (5) years.

**Accommodation and Food**

- IA** Employee has full control of their legal documents (e.g., passport) via an employee’s representative, lock boxes, or coordination with the embassy.
- IA** Dormitory residents must not be restricted in their movements beyond what they agree is reasonable, given legitimate concerns for their safety or consideration for the privacy of other residents. There must be no unreasonable restrictions, such as deposits.
- CI** If the employer provides food to employees, the employer should respect the cultural needs and sensitivities of its migrant workers (e.g., consider making available different food types/ groups for different nationalities).

**Social Activities and Religious Practices**

- CI** The employer should respect the religious practices of foreign migrant workers and provide appropriate conditions to accommodate their needs.



**Repatriation**

- IA** Each foreign migrant worker shall be expatriated, at the expense of the employer, to the worker’s home country, in the following circumstances:
  - On expiry of the contract where the contract is not voluntarily renewed by the employer and employee before the employee returns, or is required to return, to his/her home country,
  - On termination of the contract by reason of the employee’s inability to comply with the provisions of the contract due to illness or incapacity,
  - Where the employer and worker have agreed it is in their mutual interest to terminate the contract.

**FOREIGN MIGRANT WORKERS  
Non-Compliances & Corrective Actions**

Finding	Corrective Action	Recommended Timeline	Verification Method
<b>IA+</b> – <b>Retention of original documents:</b> The factory requires migrant workers to submit original copies of Passport or national ID documents or deposit money, or any legal identification papers (unless requested by workers for security reasons), so workers cannot easily leave or resign from the factory.	The factory must return all deposited money; copy the said documents and then return to the workers and put a stop to the practice. The factory must have a policy/process in-place for workers who want to terminate employment (resigning), and this must be communicated to workers. Provide workers with means for securing money and/or papers themselves (e.g., secure storage).	2 weeks	
<b>IA</b> – <b>Mandatory overtime hours:</b> In the appointment letter of migrant workers, 11 working hours in a day (with 3 hours OT) has been mentioned as mandatory.	The employment contract must be revised immediately. Overtime must be strictly voluntary. Any form of pressure to perform overtime is prohibited. The factory shall correct their working hours policy for migrant workers and communicate with the workers accordingly.	Immediately	
<b>IA</b> – <b>Freedom of Movement:</b> In Factory “A”, foreign migrant workers are not allowed to go to the toilet or get a drink of water without prior consent of factory or production manager.	Migrant Workers must have access to toilets and drinking water at all times without asking permission.  There must also be no restrictions on workers in performing traditional religious obligations.	Immediately correct practice / 2 weeks to revise policy	
<b>IA</b> – <b>List of recruitment agencies:</b> Factory “Y” was not able to provide any list/ details/ contract with the recruitment agencies that they are working with to hire foreign migrant workers.	Factory shall provide a list of the recruitment agencies with which they are working. This list must provide recruitment agency details (i.e., country, address, nationality) that they provide service for, info for any sub- recruitment agency with which they are working (e.g., coverage area). Factory shall also ensure the contracts with recruitment agencies are available for review.	Immediately correct practice / 2 weeks to revise policy	
<b>ZTV</b> – <b>Recruitment fees:</b> Factory “Z” withholds recruitment agency fees from the wages of the workers.	No recruitment fee(s) shall be charged to any foreign migrant worker. Factory shall immediately stop such practice and make back payment to the workers for the amount already deducted from their wages.	Immediately correct practice / 2 weeks to revise policy	

Finding	Corrective Action	Recommended Timeline	Verification Method
<b>IA+ – Employment Contract:</b> In Factory “X”, festival leave benefit was not mentioned in the appointment letter of foreign migrant workers, which is mentioned in the same of nationals.	Factory shall revise the employment contract with foreign migrant workers immediately and update the policy to ensure that the terms and conditions of employment provided to foreign migrant workers shall be not less favorable than those provided to nationals.	Immediately correct practice / 2 weeks to revise policy	
<b>IA – Language of contract:</b> Contracts are not prepared in the language of migrant workers, and workers are not fully aware about the terms and conditions of the employment contract.	Factory shall issue the translated copy of contract to the foreign migrant workers immediately in their languages and also ensure that contracts are prepared in 3 languages (English, language of employee and language of country of employment). Factory shall be responsible for any deviation in translations.	Immediately correct practice / 2 weeks to revise policy	
<b>IA – Transfer:</b> 100 foreign migrant workers of Factory “X” have been transferred to Factory “Y”. Factory “X” was not able to share any details of this transfer.	Factory shall strictly comply with labor laws with regard to terms and conditions included in individual contract of employment. Factory shall not transfer any worker to another factory/ organization going beyond the terms & conditions of employment contract.	Immediately	
<b>IA – Notice period :</b> In factory “Z”, the notice period to terminate the employment contract is not mentioned in the appointment letter of foreign migrant workers.	The factory must immediately revise the contract of migrant workers and ensure that the contract entitles either party to terminate the contract on giving due notice which is reasonable in length and not contrary to the interests of the worker. (Not more than 2 months, unless required by local law).	Immediately correct practice / 2 weeks to revise policy	
<b>ZTV – Minimum Wages:</b> Foreign migrant workers of factory “Z” were not receiving the minimum wages stated by the labor laws applicable to migrant workers. Also, said workers were receiving less wages and benefits than those provided to nationals.	Factory shall provide legal minimum wage to the foreign migrant workers and also ensure the wages and benefits to foreign migrant workers are not less favorable than those provided to nationals.	Immediately correct practice / 2 weeks to revise policy	
<b>IA – Facilitator:</b> No facilitator is present in factory “Y” who speaks the language of both the migrant workers and the employer.	Factory shall appoint a facilitator who speaks the language of both the migrant workers and the employer, to ensure proper communication between management and the workers.	2 weeks	

Finding	Corrective Action	Recommended Timeline	Verification Method
<b>IA – Repatriation cost :</b> In Factory “X”, repatriation cost of migrant workers found deducted from the amount of final settlement.	Factory shall immediately stop this practice and ensure that migrant workers are expatriated at the expense of the employer to the worker’s home country.	Immediately correct practice / 2 weeks to revise policy	
<b>CI – Food:</b> In factory “Z”, foreign migrant workers of a specific country are informed that the factory was not providing their preferred types of foods during lunch, whereas the nationals and migrant workers of other countries are receiving foods during lunch as per their cultural needs.	Factory shall respect all employees’ cultural food needs, regardless of employee country of origin and regardless of whether the employee is a foreign migrant worker or a national.	4 weeks to develop the policy	
<b>CI – Religious practices:</b> A group of foreign migrant workers who are all Muslims are not provided enough time for prayer during Ramadan (fasting month of the Muslims).	The employer should respect religious practices of foreign migrant workers and provide appropriate conditions for their needs.	4 weeks to develop the policy	

---

## DORMITORIES

**Business partners who provide residential facilities for their workers should provide safe and healthy facilities.**

### Requirements





- IA+** Dormitory residents must not be restricted in their movements beyond what they agree is reasonable, given legitimate concerns for their safety or consideration for the privacy of other residents. There must be no unreasonable restrictions, such as deposits.
- IA+** Dormitories must have at least 2 unobstructed emergency exits per floor that lead to a safe location.
- IA+** Exit doors must open in the direction of egress (outwards), be unlocked from the inside, and require no special operation.
- IA+** Dormitories must have an audible fire alarm that can be heard in all parts of the building.
- IA** Exits must be marked by signs that are internally illuminated and backed up by a battery.
- IA** Dormitories must be in compliance with all housing laws and regulations, occupancy requirements, and health and safety laws.
- IA** There must be smoke detectors on each floor of a dormitory.
- IA** A fire extinguisher must be located within 23 m (75 feet) of every bed.
- IA** Fire/emergency evacuation drills must be practiced at least once a year so that residents are familiar with evacuation procedures.
- IA** There must be 3.7 square meters per worker. In addition, ceilings in the room must be 2.2 meters (7 feet) high.
- IA** Toilets must be clean (recommended is 3x per day), functioning, well-lit, well-ventilated, and stocked with toilet paper and soap. In addition, there must be at least one toilet, separated and marked by gender, for every 15 occupants whose units do not have private toilets. Toilets must be connected to a public sewer system or septic tank.
- IA** All hallways and exits should be clear and unobstructed at all times.
- IA** Cafeterias and kitchens should be clean, equipped with cooking stoves, mechanical refrigeration, adequate counter space for food preparation, dining table and seats, sinks with hot and cold running water, and proper lighting and ventilation. Food storage and preparation should be sanitary. Also, cafeteria kitchens should contain a fire extinguisher and a fire blanket.

- CI** Dormitories should be safe, well-lit, well-maintained, clean, and adequately heated and cooled.
- CI** Dormitories should have emergency lighting installed in exits, hallways, and stairwells.
- CI** A first aid kit should be provided in a visible, accessible location. In addition, trained first aid personnel should be readily accessible, and there should be adequate means for reporting emergencies (such as security personnel with phones).
- CI** A lockable space sufficient for all work and non-work items with at least 1.7 square meters of storage per worker should be provided.
- CI** At least one shower with both hot and cold water should be provided for every 10 occupants. In addition, showers should be separated and marked by gender. Shower drains should be connected to a public sewer system or septic tank.
- CI** At least one sink with both hot and cold water should be provided for every six occupants. Sinks and drains should be connected to a public sewer system or septic tank.
- CI** The living quarters should be clean.
- CI** Potable water for drinking should be available on each floor.
- CI** Floors in the living quarters should be dry.
- CI** All equipment and fixtures should be well-maintained and equipped with appropriate safety devices.
- CI** Refuse containers should be located away from living accommodations, kept in a sanitary manner (a twice per week cleaning is recommended) and should be adequate for occupants' needs.
- CI** At least one washing machine per every 50 occupants or one laundry tray/tub per 30 occupants should be provided. A drying area with adequate ventilation should also be provided.
- CI** A recreational area should be provided for use by dormitory residents.

**DORMITORIES**  
**Non-Compliances & Corrective Actions**

Finding	Corrective Action	Recommended Timeline	Verification Method
<b>IA+ – Dormitories:</b> Workers are not allowed to freely leave dormitories, i.e. They must deposit personal documents with the guards before they are allowed to leave.	Cease unreasonable restrictions and communicate the changes to the workers.	Immediately / 2 weeks for communication	
<b>IA – Dormitories:</b> In Country X, some dormitory rooms are being converted to warehouse/workshop areas.	The dormitory rooms must be used for living space only. They must be converted back to living areas.	4 weeks for plan / 4 weeks to comply	
<b>IA+ – Dormitories:</b> There is only one exit on the second floor of a dormitory through one central staircase.	Construct at least one additional emergency exit.	4 weeks	
<b>IA – Dormitories:</b> The second-floor exit was not marked with an exit sign.	Install the necessary signs.	1 week for signage / 3 weeks for hiring	
<b>IA – Dormitories :</b> One of the emergency exits is locked and has a box next to it that has a glass door that has to be broken to get the door key.	Change the doors so that they remain unlocked from the inside and require no special operation. The doors must open outward.	2 weeks	
<b>IA+ – Dormitories:</b> When asked, the contractor says that the dormitory does not have fire alarm.	Install a fire alarm.	4 weeks	
<b>IA – Dormitories:</b> No smoke detectors were found in dormitory sleeping areas and hallways.	Install the necessary detectors.	Immediately take action to acquire / 3 weeks to correct	
<b>IA – Dormitories:</b> There is only one fire extinguisher near the kitchen of the dormitory. There are no extinguishers in or near the sleeping areas.	Install fire extinguishers within 23 m (75 feet) of every bed.	1 week	



Finding	Corrective Action	Recommended Timeline	Verification Method
<b>IA – Dormitories:</b> The space for each occupant is less than 3.7 square meters or local requirement.	Reduce the number of people per room or increase the number of rooms.	8 weeks	
<b>IA – Dormitories:</b> The toilets are dirty and not cleaned on a regular basis.	Clean toilets and ensure that regular cleaning is performed.	2 weeks	
<b>IA – Dormitories:</b> Residents say there has never been a fire drill.	Practice the drill annually and document the results.	2 weeks	
<b>CI – Dormitories:</b> The hallway outside the kitchen is partially blocked by cans of fuel.	Clear hallways, exits.	Immediately	
<b>CI – Dormitories:</b> During a visit to the factory, a SCOC assessor notices that the dormitory rooms are too hot.	Make dorms safe, well-lit and adequately heated/cooled/ventilated.	4 weeks	
<b>CI – Dormitories:</b> There is no emergency lighting on the second floor of the dormitory.	Install the necessary lights.	Immediately take action to acquire / 3 weeks to correct	
<b>CI – Dormitories:</b> There is no first aid kit in the dormitories, only in the factory.	Provide a stocked kit. Kit to include: bandages, sterile gauze/cotton balls, adhesive tape/plasters, disinfecting/antiseptic agent, antibacterial ointment, sterile/surgical gloves, pain reliever tablets and tourniquet.	2 weeks	
<b>CI – Dormitories:</b> During dorm tour, only small lockers were provided to workers for some of their belongings. The lockers are not locked.	Improve the locker size and ensure that the lockers can be locked for the safekeeping of the workers' possessions.	4 weeks	
<b>CI – Dormitories:</b> The bathing room is an open room that does not allow for worker privacy.	Provide hot and cold water and use partitions or curtains between the different showers for privacy.	4 weeks	

Finding	Corrective Action	Recommended Timeline	Verification Method
<b>CI – Dormitories:</b> There is only one sink on each floor of a dormitory, in which there 40 people housed.	Provide at least one sink for every six occupants.	4 weeks	
<b>CI – Dormitories:</b> The toilets are dirty and not cleaned on a regular basis.	Clean toilets and ensure that regular cleaning is performed.	2 weeks	
<b>CI – Dormitories:</b> The dormitories are untidy and there is no regularly scheduled cleaning of them.	Proper housekeeping schedules should be in-place. The schedule should be communicated to the workers.	2 weeks	
<b>CI – Dormitories:</b> The kitchen is in poor sanitary condition.	Clean kitchens and make sure regular cleaning are performed. Upgrade the facilities if needed. Install fire extinguisher or blanket.	Immediately to clean / 4 weeks to install new fixtures	
<b>CI – Dormitories:</b> Workers say water is not safe to drink; they must buy their own.	Provide potable water for the workers.	2 weeks	

## PERMITS

### Requirements

- IA** Permits must be available for review.
- IA** Factories must have all current permits as required by law (including business and operating permits, fire-safety and electrical certificates, permits for equipment such as boilers, generators, elevators, fuel and chemical storage tanks, etc. and building, emissions and waste-disposal).

Finding	Corrective Action	Recommended Timeline	Verification Method
<b>IA – Permits:</b> The factory claims that facility has permits but the person in-charge is on leave or the documents are locked away. The factory manager says he has current permits and is willing to show them but cannot. Previous year permits are available. <b>(Note: Refusal to provide SCOC assessors with access to records is a different violation; <a href="#">see Ethical Standards</a>).</b>	Submit photocopies of permits to assessor.	1 week to submit proof of up-to-date permits	
<b>IA – Permits:</b> The factory has failed to produce any records of business operating permits for the current year or any permits for the previous year. <b>(Note: Refusal to provide SCOC assessors with access to records is a different violation; <a href="#">see Ethical Standards</a>).</b>	Obtain/renew the necessary permits from authorities. Submit photocopies of permits to assessor.	2 weeks to submit proof of application / 8 weeks to get approval	

# Environment, Health & Safety



Levi Strauss & Co. has prepared this Environment, Health and Safety (EHS) chapter to help our business partners meet our Social and Environmental Sustainability requirements. EHS requirements are no less important than meeting our quality standards or delivery time.

## IMPORTANCE OF MEETING REQUIREMENTS

One of our requirements for Health and Safety focuses on emergency preparedness. Several years ago, one of our factories in central Mexico installed additional emergency exits and conducted evacuation drills to comply with this requirement. Four months later, a massive earthquake occurred.

The factory's recent efforts to fulfill requirements ensured that its 800 employees were able to evacuate quickly and safely. As you can see, careful attention to meeting our requirements is critical to providing a safe and healthy working environment for your employees.

## USING THIS CHAPTER

We have prepared this chapter to help you meet Levi Strauss & Co.'s EHS requirements, but we do not herein identify all circumstances that might constitute "findings" in a SCOC Assessment. Rather, we address topics that are of particular importance. Each business partner must make a careful assessment of each of its workplaces to determine what measures to put in place to meet our requirements, and, of course, the requirements of the countries where it operates. To help our partners with this site-specific analysis, we not only include specific information in this Handbook, but we also identify where additional information may be found regarding each requirement. Additional safety requirements for supply chain security can be found in the relevant country shipping guides as found on the Supplier Portal.

Each of the EHS topics in this chapter is organized into four sections: Application, Purpose, Requirements, and Implementation of Requirements. **Please note that LS&Co. will hold its business partners accountable for those items identified as "Requirements" only.** The sections labeled "Implementation of Requirements" provide examples of ways to comply with the requirements. These sections close with a "Plan-Do-Check-Act" cycle, illustrating a sample strategy for implementing a specific EHS program — for example, emergency preparedness, electrical safety, etc. This strategy will help business partners integrate their EHS programs into an EHS management system.



---

**Finally, we encourage our business partners to pay close attention to the documentation and record keeping requirements.** LS&Co. assessors rely on written records to verify that business partners meet requirements such as: having established EHS procedures, conducting regular inspections, and training workers.

## **APPLICATION**

This information applies to all factories covered by Sustainability for LS&Co., unless otherwise noted.



## SAFETY COMMITTEES

### Purpose

**Safety committees can identify and correct factory health and safety issues, increase safety awareness, and improve workers' job satisfaction. The purpose of this section is to describe the requirements for having a well-run and effective safety committee.**

### Requirements

- IA** Factories should have active safety committees.
- CI** Safety committees should meet at least once per month and more often if needed.
- CI** Safety committees should include management representatives, workers from various factory operations, and union representatives (if the factory has a union).
- CI** A written record of the safety committee meetings should be agreed upon by the committee leaders, posted in a workplace location for factory workers to read, and kept on file for a minimum of five (5) years.
- CI** Head of Safety Committee should have the right to perform consultations with external experts if needed.

### Implementation of Requirements

#### *Training, Rules and Record Keeping*

- Safety committee members should be trained to:
  - Investigate accidents and other health and safety events at the factory.
  - Conduct inspections and recognize hazards ([see Prison, Forced or Trafficked Labor section](#)).
  - Identify and evaluate health and safety trends.
  - Use health and safety resources within the factory or community.
- A management representative and a factory worker should be chosen as leaders. The leaders should plan the agenda prior to the meeting.
- The safety committee should agree on rules to run the meetings effectively.

### **Hazard Assessment**

- A safety committee member should be involved in all accident and event investigations.
- Safety committees should review accident or event reports to make sure actions are taken to correct hazards and to avoid a similar event in the future. (Note: The privacy of the person (s) involved in the accident or event should be respected.)
- Safety committees should thoroughly inspect the factory once per month and record the results. (See [Risk Assessment](#), [Aisles and Exits](#), and [Housekeeping sections](#).)
- Safety committees should be able to use factory health and safety data to analyze accident and event trends. This will help safety committees focus on activities to better control hazards.

### **Hazard Controls**

- Once they have identified hazards in a factory inspection, safety committees should prioritize actions to correct these hazards as soon as possible. Safety committees should follow up on the corrective actions until they have been completed.
- Health and safety resources should be made available to safety committees, including:
  - Website link for EU: <http://osha.europa.eu/en/about>
  - Website link for U.S. OSHA: <http://www.osha.gov/>
  - The LS&Co. Social & Environmental Sustainability Handbook For further information: see

### [Appendix A](#)

---

## RISK ASSESSMENT

### Purpose

**The purpose of this section is to identify all hazards within the workplace that could reasonably be expected to cause harm and to assess the risks presented by those hazards. Hazards include, but are not limited to, those that are the subject of the other sections of the Guidebook.**

### Requirements

- IA** Factories must have a procedure for identifying workplace hazards and assessing their risks.
- CI** Factories should review their risk assessments and safety action plans on a periodic basis.

### Implementation of Requirements

#### *Training, Rules and Record Keeping*

- Individuals or teams should be trained to identify hazards, assess their risks, and evaluate the effectiveness of control measures.
- Risk assessments should be recorded in writing and made available to factory workers.

#### *Hazard Assessment*

- Individuals responsible for risk assessment should tour the entire factory, looking for operations or work practices that could harm workers or the environment. The EHS Handbook sections should be used as a guide for the types of hazards to look for, but those touring the factory should look for hazards that may not be covered by the Handbook.
- Before the tour, review Safety Data Sheets and worker accident and injury records. During the tour, ask workers to help identify workplace hazards. Focus on hazards that could result in significant harm, such as flammable materials, unguarded moving machinery parts, lack of fall protection railings (where needed), pressurized systems, chemicals without labels, chemical containers that lack secondary containment, damaged electrical wiring, fumes, extreme temperatures or noise, and high-speed ejection of material.
- Determine who may be harmed by these hazards and how.
- Assess the risk by evaluating (a) the severity of the harm that may be caused and (b) the likelihood that an event that results in that harm will occur. For example, consider workers on an elevated platform without fall protection railings. What's the worst harm that might result? (Broken bones, even death.) How likely is it that an event resulting in broken bones or death might occur? (This is a serious risk, and action should be taken immediately to install fall protection railings!)

---

### *Hazard Controls*

- The risk assessors should evaluate the existing precautions for the hazards identified in the tour. Are they adequate? Can the risk be eliminated or reduced by taking additional action?
- Prepare a report summarizing the hazards identified, the assessment of risks, and any recommendations for new risk control measures. Factories must make sure this report is available for workers to read.
- Make sure to do the hazard tour and risk assessment each year or whenever there have been significant changes to factory operations.

---

## MULTI-STORY BUILDING RISK MANAGEMENT

### Purpose

Collaboration between the different industrial workplace property managers in the same building/site is vital to achieve a safe and healthy work environment for everyone. Workplace health and safety is a critical issue for every business, and LS&Co. requires all building occupants to collaborate on taking reasonable steps to ensure that every part of the building has appropriate safety measures.

### Requirements

***Multi-story building with different owners and different businesses than proposed LS&Co. production:***

- IA** An emergency preparedness assessment must be conducted at all businesses.
- IA** An electrical safety assessment must be conducted at all businesses.
- IA** A building integrity assessment must be conducted at all businesses.

***Multi-story buildings with different owners with the same processes as proposed LS&Co. production:***

- IA** The full Social section of the SCOC assessment must be conducted at all businesses.
- IA** An unauthorized subcontracting assessment must be conducted at all businesses.
- IA** An emergency preparedness assessment must be conducted at all businesses.
- IA** An electrical safety assessment must be conducted at all businesses.
- IA** A building integrity assessment must be conducted at all businesses.

***Multi-story building under same owner with the same processes as proposed by LS&Co. production:***

- IA** A full SCOC assessment for all production floors, regardless of whether the production on that floor is for LS&Co. or another client.

***Multi-story building under same owner and different business than proposed LS&Co. production:***

- IA** An emergency preparedness assessment must be conducted at all businesses.

- 
- IA** An electrical safety assessment must be conducted at all businesses.

- IA** A building integrity assessment must be conducted at all businesses.

***Multiple buildings under one compound with the same processes as proposed by LS&Co. production:***

- IA** A full SCOC assessment for all production floors, regardless of whether the production on that floor is for LS&Co. or another client

***Multiple buildings under one compound and different business than proposed LS&Co. production:***

- IA** An emergency preparedness assessment must be conducted at all businesses.
- IA** An electrical safety assessment must be conducted at all businesses.
- IA** A building integrity assessment must be conducted at all businesses.

## EMERGENCY PREPAREDNESS

### Purpose

**Emergency events include fires, earthquakes, and accidents. Injuries to workers and damage to buildings and equipment can be reduced if emergencies are planned for in advance. This section describes the requirements for planning and preparing to protect workers in the event of an emergency.**

### Requirements

- IA** A senior factory manager must be assigned responsibility for making sure that the factory has procedures in place to prepare for and respond to emergency situations.
- IA** Factories must have procedures to prepare for possible emergencies such as fire, earthquakes, hurricanes, unauthorized persons, and chemical spills. These procedures must be written in a language that all workers understand.
- IA** Factories must have an emergency evacuation plan, and evacuation routes must be posted in each work area.
- IA** Factories should hold emergency evacuation drills often enough that workers know the drill procedure and consider it routine.
  - At least one drill should be done annually.
  - Hazardous materials emergency accident handling should be included in the fire drill.
- CI** Factories should have assigned locations that can shelter the entire worker population in case of a severe weather event.
- CI** Factories should have a fire prevention plan.
- CI** Training should be provided to workers. Evidence of it should be available, and workers should prove knowledge of the training program through workers' interviews.

### Implementation of Requirements – Emergencies that require evacuation

#### ***Training, Rules and Record Keeping***

- Workers on all shifts should be trained to use fire extinguishers.
- This training should include hands-on practice with fire extinguishers, as well as reading materials and demonstrations. Factories should keep written records to show that this training has been given.
- Factories should assign individuals with responsibility for planning and holding emergency

evacuation drills. These individuals should be qualified to lead the drills. Drills should be held at various times and under various conditions to model an actual emergency.

- Workers should be trained on emergency evacuation procedures. Visitors should also be informed about evacuation plans.
- Factories should keep records of emergency evacuation drills.
- These records should include details about the drill (e.g., the time the last person exited the building, an accounting of all workers, any issues noticed during evacuation, plans to correct such issues). Records should also be kept on the maintenance and testing of emergency equipment (such as fire extinguishers, lighting, alarms, etc.).
- Factories should post “Danger,” “Warning,” and “No Smoking” signs where needed and in a language that all workers understand.

### ***Hazard Assessment***

- Factories should consider all the types of emergencies that may occur at their location (e.g., fire, chemical spill, earthquake, typhoon, etc.) and include them in emergency preparedness procedures. ([See Appendix](#)).

### ***Hazard Controls***

- Factories should have rules and procedures to make sure that aisles and exits are kept clear, are properly and clearly marked, and allow workers to quickly and safely leave the factory in an emergency. ([See the Aisles and Exits](#) section.)
- Factories should have emergency evacuation procedures that require all workers and managers to participate in drills. During a drill, workers and managers should leave the building, go to the assigned location (assembly area), and remain there until a signal is given to return to the factory. The focus should be on orderly evacuation rather than on speed. Factories should hold at least one emergency evacuation drill every year, during which all workers are evacuated within 3 minutes.
- Emergency lights should be tested regularly and kept in proper working order. ([See Lighting section](#).)
- Fire extinguishers should match the potential fire hazard and should be located within 15 m (50 ft) of flammable liquids and 23 m (75 ft) of every worker. ([See Appendix](#).)



**Good practice: Fire extinguisher types for potential hazards are provided and tagged**

- Fire extinguishers should have maintenance tags attached to them to indicate the date they were last checked and serviced. In addition, there should be a diagram that shows workers how to use fire extinguishers in the immediate area.
- A reasonable number of battery-operated emergency lights should be placed in useful locations in order to light aisles, halls, and stairways along evacuation routes, with the batteries tested with sufficient frequency to ensure that they are functioning properly. (See [Lighting section](#).)
- Factories should have a separate fire alarm that:
  - has a sound that only means “fire” (and not any other type of emergency);
  - may be heard throughout the factory; can be activated at various points throughout the factory; and
  - has a back-up battery or an uninterruptible power supply.
- Alarms should be tested regularly and maintained in proper working order.
- In addition to the factory’s audible alarm, a visible fire alarm (such as a flashing light) should be installed in all work areas that require workers to wear hearing protection.



Good practice: Fire alarm switch in native language

#### Implementation of Requirements – Emergencies that require evacuation

- Factories should hold at least one shelter-in-place drill every year. Records should be kept of this drill.
- Workers should be trained on shelter-in-place procedures. (See [Appendix A](#))
- Shelter-in-place locations should be located in the most stable areas of the building (e.g., near structural supports such as load-bearing walls).

## BUILDING INTEGRITY

### Purpose

The Property Condition Guideline section outlines the procedures for evaluating the physical condition of a building. The procedures consist of a visual inspection and an interview with the property owners and managers. In addition, the assessment includes a review of building plans, documents and statutory research. Factory management shall present high level knowledge about their site, all possible natural and manmade hazards, and building integrity.

### Requirements

#### Documents, permits, certificates

- IA+** Factories shall have a valid building certificate of occupancy.
- IA** Factories shall be able to present the legal classification of the site location regarding earthquake zones, flooding areas, soil structure and saturation, groundwater level, torrential rainfall, flooding, snow loading, and landslide.
- IA** Factories shall be able to make available to the assessor the design and descriptions of the building structure, including blueprints, general construction details such as type of material used in framing, information on the foundation, walls and floors, and type of roof.
- ZTV** *If the above 3 points are not met, then the factory shall commission and pay for a building integrity survey by an LS&Co- approved contractor.*
- IA** Factories shall be able to present to the assessor the extent to which the building can resist certain local climatic conditions such as wind, earthquake or hurricane force winds, and flooding.
- IA** Factory management shall be able to present to the assessor the permit for the maximum number of people allowed to be in the building at one time. Multi-story buildings shall have the maximum occupancy number for each floor posted on the floor.
- CI** Factories shall have a list of all building components, including but not limited to stairwells, staircases, rails, verandas, hallways, doors, windows, walls and roofs, HVAC systems, fire and safety equipment, elevators, and electrical systems.
- CI** The listing for each building component shall be accompanied by a detailed description of its condition and the dates of the previous and annual schedule of periodic preventive checks and maintenance.

**CI** The comprehensive list of building components shall be a tool to track the health and safety of the building and shall be reviewed and approved periodically by the factory owner or general manager.

**CI** Factories shall be able to present proof of regular inspection by a competent technician regarding plumbing, roofing, interior and exterior building structure and heating, air conditioning, and ventilation systems performed by a competent technician.

### **Structure**

**IA+** Factories' structure shall not exceed the maximum expected loads described by the building's certificate of occupancy.

**IA** The building structures shall be verified to comply with the earthquake demand of three-quarters (3/4) of the current local requirements for new construction with similar occupancy ratings.

**IA** The buildings shall meet the basic Tier 1 acceptance criteria established by ASCE 41-13, or a similar country seismic standard for evaluating existing buildings.

**IA** Factories shall be able to document that staircase installations ensure adequate access and exits for the maximum number of people expected in the building at one time.

**IA** Factories shall provide unobstructed road access to the building and ensure adequate access to emergency equipment and adequate access to the unobstructed road from the emergency exits for the building's maximum permitted occupancy.

**CI** Factories shall be in good repair, free from signs of vandalism, with walls, doors, and windows free from cracks, broken panes, or other damage.

**CI** Factories' building components shall be well maintained with a remaining life of at least 10 years. Items that need repair, such as loosened railings, cracked windows, damaged walls, exposed wires, leaking roof areas, and damaged fixtures, walls, and columns, shall be reported and corrected immediately.

**CI** Factories shall be able to present evidence of maintenance work or repairs (for example, each visually recognizable repair undertaken).

### **Safety Procedures**

**IA** A senior factory manager shall be assigned responsibility for making sure that the factory has proper procedures in place to prepare for and respond to emergency situations at the factory and shall ensure that these are understood by each employee before undertaking work at the factory.

**IA** Factories shall have procedures to prepare for possible emergencies such as fire, earthquakes, hurricanes, and chemical spills. These procedures must be written in a language that all workers understand.

**IA** The emergency preparedness shall give emphasis that suppliers in high seismic risk shall specifically address earthquake preparedness.

**IA** Factories shall have an emergency evacuation plan, and evacuation routes must be posted in each work area.

**IA** Factories shall have a training program for all employees that cover the building safety elements, signs of potential problems, and the immediate reporting channels.

**IA** Factories must have access controls to prevent unauthorized access to the facility.

**CI** Evidence of high-quality worker building safety training shall be available for review and workers should demonstrate knowledge of the training program through worker interviews.

### **Hazard Assessment**

**CI** Factories shall be prepared for all the types of emergencies that may occur at their location (e.g., fire, chemical spill, earthquake, typhoon, etc.) and include them in emergency preparedness procedures.



## AISLES AND EXITS

### Purpose

The purpose of this section is to make sure that factory aisles and exits are kept clear, are well marked, and allow workers to quickly and safely exit the factory in an emergency.

### Requirements

- IA+** Emergency exits must be unlocked during working hours so workers may exit during emergencies.
- IA+** Factories must have enough exits to safely serve the number of workers and the height and type of building or structure:
  - Factory floors with 150 or fewer workers must have at least 2 (non-elevator) exits. Factory floors with more than 150 workers must have at least 3 (non-elevator) exits. Exits must lead to a safe location outside the building and must be within 61 meters (200 feet) of every workstation.
  - Buildings with 1000 or more workers must have at least 4 exits.
  - Additional exits must be provided in every section of a building where size, worker population, and work area arrangement would endanger workers trying to use a single exit that is blocked by fire or smoke.
- IA+** Aisles and exits must be kept clear and unblocked at all times. Exits must be unlocked at all times during working hours.
- IA** Exit doors must open outward (in the direction of the way out of the building). They must require no special operation.
- IA** Exit doors, routes, and aisles must be wide enough to safely evacuate workers in an emergency:
  - Exit doors must be at least 81 cm (32 in) wide.
  - New exits must be at least 91 cm (36 in) wide.
  - Exit routes must be at least 91 cm (36 in) wide.
  - Aisles must be at least 91 cm (36 in) wide.
- CI** Exit doors and exit routes should be marked so that they are clearly visible to factory workers throughout the factory:
  - Exits should be marked with signs that are visible from 30 m (100 ft).
  - All signs and markings should be in a language(s) that can be understood by all workers. Lettering should be at least 15 cm (6 in) high, brightly colored, contrasting with surrounding surfaces, and illuminated to make it more visible.

- Any door, aisle, or stairway that is NOT an exit or does NOT lead to an exit and may be mistaken for an exit shall be posted with a sign that reads “NO EXIT.”

- IA** The facility must have a fire detection and protection system and required equipment (emergency alarm, smoke detection system, fire extinguishers, hydrant, etc.) as per the local legal requirement. At the minimum, factories should have a separate fire alarm that has a sound that only means “fire” (and not any other type of emergency); may be heard throughout the factory; can be activated at various points throughout the factory; and has a back-up battery or an uninterruptible power supply
  - Alarms should be tested regularly and maintained in proper working order.
  - In addition to the factory’s audible alarm, a visible fire alarm (such as a flashing light) should be installed in all work areas that require workers to wear hearing protection. (Also see [Emergency Preparedness Section](#).)



**Bad Practice (IA):** Fire exit is blocked by trash container and equipment

- CI** An assembly area should be assigned outside the factory so that evacuated workers can be accounted for in an emergency.

- CI** Any changes to building design should be reviewed to make sure that they meet the requirements of this topic before they are implemented.

### Implementation of Requirements

#### Training, Rules, and Record Keeping

- When they are first hired, workers should be trained on the location of exits and evacuation routes, and on the importance of keeping aisles and exits clear. (See [Emergency Preparedness Section](#).)
- All workers should be able to show they understand the above training and any related documents the factory or LS&Co. may provide on this topic.

#### Hazard Assessment

- Factories should inspect all areas of buildings to ensure they meet the requirements listed in the checklist in the Appendix.

#### Hazard Controls

- Factories should inspect building areas each month to make sure they meet the aisle and exit requirements. (See [Safety Committee Requirements](#) for further information.)



**Good Practice:** “Exit” sign in local language

## LIGHTING

### Purpose

Poor lighting or a complete lack of lighting (in the event of a power failure) may prevent workers from seeing possible hazards. The purpose of this section is to describe requirements for workplace and emergency lighting to help provide a safe working environment for all factory workers.

### Requirements

**IA** Factories that have night work or low natural lighting levels must provide emergency lighting in case of a power failure.

**CI** Lighting should meet the following required lux levels in the workplace:

Working Condition	Minimum Lighting Value (lux)
Rarely visited locations, with limited perception of detail required (e.g., storage rooms)	50
Factory floor and other continuously occupied areas (e.g., walkways) where fine detail perception is not required	200
General Office	500
Machine operator workstations, drawing board workstations, bench work, and other workstations that require fine detail perception	750

Source: Evaluation of Human Work, Second Edition, 1995, Wilson and Corlett

### Implementation of Requirements

#### Emergency Lighting

##### *Hazard Assessment*

- Factories with night shifts should make sure that emergency lighting meets the following requirements:
- Average required lighting should be 10 lux (1 ft-candle) at the floor level.
- Emergency lighting should be supplied for at least 1.5 hours if normal lighting fails, and lighting should be no less than 10 lux (1 ft-candle) at the end of that time.

- If maintaining light requires a change from one energy source (e.g., a public utility) to another (e.g., a private energy generator), any delay in providing lighting may be no more than 10 seconds.
- Factories without night shifts should evaluate natural lighting of the exit routes and determine whether it is at least 0.1 ft candle (1 lux) at floor level. If it is not, the factory should act to install emergency lighting (that meets the above requirements) in the building.

##### *Hazard Controls*

- Factories should test the emergency lighting system every 30 days for no less than 30 seconds.
- Once each year, factories with night shifts should practice the emergency evacuation of the building using only emergency lighting.
- If battery-powered emergency lighting systems are used, they should be tested each year for no less than 1.5 hours. Factories should keep written records of these tests.

#### Required Workplace Lighting Levels

##### *Hazard Assessment*

- Factories should evaluate all areas and working conditions to make sure they meet the minimum lighting values described in the Requirements section above.

##### *Hazard Controls*

- Where areas or working conditions fail to meet the minimum lighting values, factories should act immediately to correct the situation.
- Factories should assign responsibility for maintaining proper lighting (cleaning, replacing, repairing lighting fixtures, etc.).

---

## HOUSEKEEPING

### Purpose

**Good housekeeping is an important factor in preventing injuries, illnesses, and property damage that may result from hazards such as trips, slips and falls, falling objects, fires, and pest infestation.**

### Examples of accidents caused by poor housekeeping include:

- tripping over loose objects on floors, stairs, and platforms
- being hit by falling objects
- slipping on greasy, wet, or dirty surfaces
- striking against poorly stacked items or misplaced material projecting into aisles
- cutting, puncturing, or tearing the skin of hands or other parts of the body on projecting nails,
- wire or steel strapping

**The purpose of this section is to promote good housekeeping to protect workers and factory property.**

### Requirements

- IA** Lint traps in dryers must be routinely cleaned, and the lint removed and discarded.
- CI** Factories should keep stairs, aisles, and exits clean. (See [Aisles and Exits](#) for further requirements.) Materials should be kept neat and orderly.
- CI** Scrap materials should be cleaned up daily or often enough to prevent them from collecting on floors, tabletops, in aisle ways, or other areas.
- CI** Litter should be stored in non-combustible containers with lids.
- CI** Building roofs and roof drains should be kept clean and unclogged.
- CI** Outside storage should be at least 7.5 meters (25 feet) away from building walls.
- CI** Heating, ventilation, and air conditioning systems should be cleaned and maintained regularly.

**Note:** See also the Requirements in Solid Waste Management.

---

## Implementation of Requirements

### *Training, Rules, and Record Keeping*

- Workers should be trained on how to properly store tools and equipment and where and how to dispose of waste.

### *Hazard Assessment*

- Factories should create and use a housekeeping inspection checklist to make sure housekeeping requirements are being met. ([See sample checklist in Appendix.](#)) Individuals should be assigned responsibility for doing housekeeping inspections on a regular basis.

### *Hazard Controls*

- Factories should take action to correct conditions or situations that do not meet the housekeeping requirements. This may include improving cleaning procedures, doing building and equipment maintenance work, and changing work area design to create proper storage areas for tools, equipment, and materials.
- Tools and equipment should be provided to clean up waste (brooms, dust pans, vacuums, etc.).
- Factories should assign responsibilities for the following:
  - Clean up during the shift
  - day-to-day cleanup
  - waste disposal
  - removal of unused materials

## ELECTRICAL SAFETY

### Purpose

**Accidental contact with electric current may result in electric shocks, contact burns, and even death if proper protective measures are not taken. Wiring and electrical systems such as sockets, panels, motors, fuse boxes, and transformers that are not well-maintained can overheat and become a fire hazard. The purpose of this section is to help reduce threats to workers, equipment, and buildings from electrical shock or electrical fires.**

### Requirements

**IA+** All electrical equipment must be properly grounded.

**IA** Factories must maintain wiring and electrical systems in safe condition.

- All electrical wires must be properly insulated.
- All electrical junction boxes must be covered.
- A Ground Fault Circuit Interrupter (GFCI) is used in areas where moisture is present or humidity is high.
- All electrical connectors must be in good condition.
- Violation may be rated **CI** if the general wiring condition is good, management systems are in place, and a certified electrician maintains electrical systems on a daily basis.

**IA** Factories that have electrical responsibility within the facility are required to have regular electrical safety training. Written records must be kept of this training.

**IA** Permanent and stationary equipment must have hardwired electrical connections only.

**IA** Electrical panels are labeled, and breakers identify the equipment they protect.

### Implementation of Requirements

#### *Training, Rules and Record Keeping*

- Provide maintenance workers with electrical safety training when they are first hired, and make sure they are retrained each year after that
- Only those workers that have been trained and authorized may work with electrical systems.
- Factories should keep written records to show this training has been completed.

### Hazard Assessment

- Perform regular inspections of equipment and electrical installations to make sure they are in good working condition and do not present electric shock or fire hazards.
- Identify each piece of equipment or machinery that presents electrical or mechanical hazards to maintenance workers. Contact the equipment manufacturer to obtain appropriate electrical safety information, if necessary. Prepare a written procedure for de-energizing, locking, and tagging each machine out before performing any maintenance on it. ([See the LOTO interactive training program identified in “Further Information” section](#) below.)

### Hazard Controls

- Grounding is an electrical connection to earth. A ground wire carries electrical current to earth when there is a leak in a circuit. Use building ground for all AC outlets, motor grounds, etc. Never use the neutral circuit wire as the electrical ground.
- A Ground Fault Circuit Interrupter (GFCI) is an electrical breaker that protects against an accidental short or overload of an electrical circuit. This device trips, cutting off the electrical current at the slightest indication of an electrical short. Ground Fault Circuit Interrupters should be used in areas where there is moisture or humidity is high (for example, outlets close to water hose line, water faucets, etc.).
- Regularly test and maintain electrical panels, tighten electrical connections, and test electrical motors at “full load” (maximum electrical current or amperage) to identify loose connections that may create a fire hazard.
- Use adequate wire size and connectors, according to current load, for temporary electrical connections. Undersized wire or loose connectors are the most common causes for wire overheating that may lead to fire hazards. Temporary installations should be kept only for the length of time specified by the work.
- Label and identify electrical panels as to the type of voltage (480V / 220V; 240V / 120V, etc.). Label each circuit breaker.
- Electrical panels should always be closed and locked. Keys for electrical panels should be kept in a centralized area and made available only to authorized personnel.
- Make sure there is easy access (approximately 1 meter or 3 feet) to electrical panels and transformers. Do not allow electrical panels or transformers to be blocked by equipment or stored materials, and keep flammable or combustible materials away.
- To reduce the risk of electrical shock, cap or otherwise close any openings left in electrical enclosures (electrical panels, boxes, etc.) from removed electric piping, circuit breakers, etc.



**IA** Circuit breaker with exposed and damaged wiring! Circuit breakers must be labeled and enclosed.

- 
- Before using portable cord and plug-connected equipment and extension cords on any shift, inspect them for defects such as loose parts, deformed and missing pins, or damage to the outer jacket or insulation. Do not allow the use of damaged or defective equipment or cords. Such items should be repaired (if possible) or discarded.
  - Avoid hanging electric extension cords from the ceiling if possible. If these are to be used, make sure to have a strain relief mesh or similar device to prevent strain on the outlet or damage to the extension cord.

---

## CONTROL OF HAZARDOUS ENERGY / LOCK-OUT/TAG-OUT

### Purpose

**“Control of hazardous energy” refers to the practices and procedures that are needed to disable machinery or equipment to prevent it from unexpectedly re-energizing or starting up while workers perform servicing and maintenance activities on it. These types of controls (typically referred to as “Lock-Out/Tag-Out”) prevent many deaths and injuries each year. The purpose of this section is to describe requirements for the control of hazardous energy that will help make sure servicing and maintenance activities are safely performed.**

### Requirements

- IA** Factories must have written lock-out/tag-out and maintenance procedures to keep maintenance personnel and equipment operators safe during operations such as maintenance, un-jamming of machines, needle changes, or changing of dies or machine parts.
- IA** Each piece of machinery or equipment must have its own electrical, pneumatic, or hydraulic disconnect switch or valve so that the individual machine or piece of equipment can be isolated from the others.
- IA** Before a worker may be authorized to lock out and tag out equipment, he/she must be trained in lock-out and tag-out techniques and procedures by experienced personnel.

### Implementation of Requirements

#### Training, Rules and Record Keeping

- Factories should make sure that new equipment, or modification and repairs done to existing equipment, includes the capability of having all energy sources locked out (rather than simply tagged out).
- Factories should establish and maintain lock-out or tag-out procedures that are specific for each piece of equipment that requires service or maintenance. Procedures should provide for group lock-out (using a group lock-out device to which individuals lock their personal devices), for the orderly transfer of lock-out devices during shift changes, and for emergency removal of locks.
- Factories should provide authorized workers with standardized lock-out/tag-out devices and a reliable means of locking or tagging equipment

- In addition to the training in the Requirements above, factories should provide training to all workers who operate or work with machinery and equipment on the related hazards, including electrical hazards.
- Conduct training and maintain records of the:
  - Annual program assessment
  - [Annual Inspection checklist](#) (see Appendix)
  - [Annual Certification Form](#) (see Appendix)
  - Training for all machine operators/workers and for those authorized to do lock-out/tag-out work.
  - Inform any contractors working on equipment of the lock-out / tag-out procedures and the requirement to follow them.

### **Hazard Assessment**

- Factories should identify the types of activities and the machines and equipment that require lock-out/tag-out of hazardous energy sources, including new equipment. Make sure new or modified equipment is capable of having all energy sources locked out (rather than simply tagged out).
- Factories should evaluate the lock-out/tag-out program each year, to make sure there are proper lock-out/tag-out procedures for machines and equipment that require them and that workers are following these procedures.

### **Hazard Controls**

- Factories should create and use procedures for safe service and maintenance of equipment. These procedures will differ for equipment that is cord-and-plug connected. Below are procedures for powering off and servicing cord-and-plug connected equipment and for general lock-out / tag-out of equipment. Factories should write specific procedures for individual devices or equipment.

### **Power-Off Procedure for Cord- and Plug-Connected Electric Equipment**

The following procedure applies to work to be done on electric equipment that is connected to its energy source by a cord and a plug. By unplugging the equipment from the energy source (electrical outlet) and having control over that plug, the worker performing the service or maintenance prevents unexpected reenergizing or start-up of the equipment.

- |  |   |
|--|---|
| 1. Stop work and turn the control switch to the “OFF” position.              | 3. Wait for all machine or equipment action to stop.  |
| 2. Unplug any electrical power sources and keep the plug under your control. | 4. Test equipment to make sure the machine has stopped (e.g., depress treadle, push hand controls). |

5. Perform the service or maintenance task (e.g., needle or bobbin changes), and do not place any part of the body in a dangerous location or position.
6. Reinstall all removed safety devices.
7. Plug the equipment back into the energy source and turn the control switch to the “ON” position to test and ensure adjustments were correctly performed.

### **General Lock-Out/Tag-Out Procedure**

1. Identify the primary equipment to be maintained and any additional equipment associated with it.
2. Review the specific lock-out/tag-out procedure(s) for the device or equipment.
3. Notify the workers (e.g., operator, team members, and supervisors) who use the equipment or work around it that lock-out/tag-out and maintenance work is to be performed.
4. Turn the equipment off (follow normal shut-down procedures).
5. Isolate all associated energy sources and discharge the stored energy until you have achieved a zero state (e.g., bleed all pressurized lines, discharge electrical circuits).
6. Block and/or restrict all machine parts that may move and, therefore, pose a hazard during maintenance work.
7. Attach a tag to the affected equipment.
8. Attach a lock to isolate equipment from energy sources.
9. Turn the machine’s power sources on as a test. The equipment should not be operable, and any stored energy should be completely discharged.
10. Turn the equipment power sources back to the “OFF” position.
11. Complete service, repairs, and/or adjustments.
12. Restore equipment to service:
  - Replace all covers and safety devices.
  - Inspect equipment.
  - Verify that all workers are clear of the equipment.
  - Remove locks and tags.
  - Turn the equipment energy source(s) back to the “ON” position.
  - Test equipment for proper function.
13. Notify affected workers that the equipment is ready for use and that lock-out/tag-out is no longer in use.

## MACHINE GUARDING

### Purpose

Machine guards can prevent injuries to workers caused by machine hazards such as moving parts, high temperatures, and lasers. Workplace injuries that may be caused by machine hazards include crushed fingers or hands, amputated fingers or hands, burns, and blindness. The purpose of this section is to explain the requirements for machine guarding to help prevent such injuries.

### Requirements

- IA** All machinery with exposed, moving, mechanical parts must be equipped with safety devices. For these parts, all required protective guards must be in place.
- CI** Workers should be given machine guarding safety training on the machines they operate.
- CI** Factories should assess the hazards of new and existing equipment to determine whether existing guards are effective in protecting workers, or if other machine guards should be added to control hazards.
- CI** Factories should routinely inspect equipment to make sure equipment guards are in place and working properly.

### Implementation of Requirements

#### Training, Rules and Record Keeping

- Anyone who will be operating or servicing machines that may pose safety hazards should first be trained on the specific procedures for safely operating or servicing the equipment. They should be trained about the hazards of the equipment and about how to use machine guards to operate the equipment safely. ([See Appendix.](#))
- Factories should keep written records of equipment service.

#### Hazard Assessment

- Check any new equipment (that is, powered or power transmission equipment) to make sure that it has the right machine guards for the hazards it poses.
- Make and keep a list of the equipment that has machine guards. Include the equipment location, the type of equipment and the type and numbers of machine safeguards on the equipment.
- Factories should keep written records to show this training has been completed.

### Hazard Controls – General

- Guards should be made of metal or, where visibility is required, they may be made of sturdy plastic or safety glass.
- Guards may be made of wood in areas where materials are present (acids and bases) that would corrode (wear away) a metal guard.
- Nip points on conveyors should be guarded.
- Steam irons and fabric presses should have handle and pedal guards to protect the operator's arms and legs from burns.
- Work areas should be arranged to protect workers from contact with surrounding equipment, such as the cables for steam irons.



**Good Practice: Grinding wheel with eye shield in place**

### Hazard Controls – Machine/Maintenance Shops

- Eye shields should be installed on grinding wheels to prevent flying objects from injuring the operator.
- Grinding wheels should be permanently secured to a bench top.
- Tool rests and tongue guards should be installed and properly adjusted on grinding wheels to safely direct any flying objects away from the operator.
- Cutting blades and other points of operation on workshop machinery should be guarded to prevent wood chips, splinters, or pieces of a broken cutting blade from flying off the equipment and injuring the operator.
- Belt-sanding machines should have guards at each nip point where the sanding belt runs onto a pulley.
- All portable, power-driven, circular saws with blades greater than 5 cm (~2 inches) in diameter should have guards.
- The lower guard of a portable, power-driven, circular saw should automatically and instantly return to cover the blade when the saw is not in use.
- Machine tools should be bolted to the floor, so they don't tip or fall when operated.

### Hazard Controls – Sewing Factories

- All sewing machine needles should have needle guards to prevent injuries to the operator from broken needles. Sewing needles that are permanently protected by fabric folders or guides do not require the needle guards.
- Operators should wear safety glasses when operating sewing equipment unless the machines have eye shields.

- Moving machine parts and drive belts should be guarded at the point of operation (the area where the machine performs work). In a fabric cutter, for example, the point of operation is where the blade contacts (and cuts) the fabric.

#### **Hazard Controls – Laundry Facilities**

- Laser-etching machines should have barrier guards and interlocks to keep operators from opening them while the laser is on. Interlocks will automatically shut off the machine if the barrier guard is removed or opened.
- Gears, drive belts, and other moving parts on washers and dryers should be guarded.

## **POWERED INDUSTRIAL TRUCKS**

### **Purpose**

**Powered industrial trucks can cause serious injury to operators and co-workers if they are not properly maintained or if operators are not properly trained. Equipment collisions can also damage property and interrupt production. The purpose of this section is to help make sure that workers are properly trained and qualified to operate powered industrial trucks.**

Powered industrial trucks include the following:

- Forklifts
- Material pickers
- Turret trucks
- Golf carts
- Lowboys
- Highboys
- Powered hand trucks

### **Requirements**

- IA** Only authorized workers, who have been properly trained and evaluated, may operate or maintain powered industrial trucks.
- CI** Each powered industrial truck should be inspected at the beginning of every shift to make sure it:
  - functions properly and safely, and
  - does not create hazards.
- CI** All workers who use, adjust, or maintain powered industrial trucks should be trained to perform these jobs safely.
- CI** All industrial truck operators should complete the requirements for re-qualification periodically. The operators' safety performance should be evaluated frequently.
- CI** Industrial truck operators should be re-trained and disciplined if the operator has been: observed to operate the equipment in an unsafe manner or involved in an accident or near-miss incident

**Note:** *Industrial truck operators shall be re-trained if, at any time, they are assigned to drive a different type of equipment or if there are changes in the workplace that affect the safe operation of the equipment.*

- CI** All powered industrial trucks should have audible back-up alarms while in reverse.
- CI** Factories should make sure that all contractors, vendors and visitors that may use powered industrial trucks understand that they should become qualified to use this equipment and how to meet the qualification requirements.



---

## Implementation of Requirements

### ***Training, Rules and Record Keeping***

- All workers should be instructed that they may not use or maintain powered industrial trucks unless they have been trained and are qualified to do so:
- Operators of powered industrial trucks should be trained and qualified for the specific equipment they operate or maintain.
- Training should include:
  - Formal instruction (e.g., lecture, discussion, interactive computer learning, videotape, written material)
  - Practical or hands-on instruction (e.g., demonstrations by the trainer, exercises done by the trainee)
  - Observation and evaluation of the operator's performance with the equipment in the workplace
- Operators should pass written and operational tests to be qualified to operate powered industrial trucks.
- Trainers should have the knowledge and experience to train equipment operators and evaluate their ability to safely operate powered industrial trucks.
- Factories should certify that each powered industrial truck operator has been trained and has passed the qualification test. The written certification should include the: (a) operator's name, (b) training date, (c) date of evaluation, and (d) trainer's name.
- Equipment operators should be re-tested at least every 3 years. The re-qualification test evaluates:
  - the operator's prior knowledge and skill,
  - the types of equipment he or she will operate in the workplace,
  - the types of hazards in the workplace, and
  - the operator's ability to operate the equipment safely.
- Operators who pass the re-qualification test should be re-qualified for at least three years. Current operators who do not pass the re-qualification test should be re-trained, following the requirements for the initial training program. Operators may not use powered industrial trucks until they have been formally re-qualified.

### ***Hazard Assessment***

- Factories should make sure there is a procedure in place that requires workers to inspect each powered industrial truck at the beginning of every shift to make sure it is in good working condition.

---

## ***Hazard Controls***

- If, during a pre-use inspection, an operator finds that a powered industrial truck is not working properly, he or she should inform a supervisor and should not operate the vehicle until it has been repaired and it is safe to do so.
- Factories should make sure that powered industrial trucks are serviced and maintained on a regular schedule.

---

## NOISE MANAGEMENT

### Purpose

**Permanent hearing loss may be caused by a number of things, including disease, aging, sudden loud noise, or long-term exposure to loud noise. The purpose of this section is to describe requirements to manage workplace noise levels to help prevent workers from experiencing work-related hearing loss.**

### Requirements

- IA** Factories must identify workers who work in areas with noise levels that are higher than 85 decibels. These workers must wear hearing protection and be trained on the proper use of hearing protection and the health and safety risks of not wearing hearing protection. Factories must supply workers with the necessary hearing protection (ear plugs, earmuffs). Factories must keep written records that show this training has been completed.
- IA** Factories must meet legal requirements to test workers' hearing to determine whether they have experienced any hearing loss.
- CI** Factories should conduct noise hazard evaluations each year to identify any areas where noise levels exceed 85 decibels.
- CI** Factories should first attempt to reduce noise levels that are higher than 85 decibels through proper maintenance of equipment and engineered noise controls.

### Implementation of Requirements

#### *Training, Rules and Record Keeping*

- Workers in areas where noise levels are higher than 85 decibels should have an audiometric test to determine if hearing loss has occurred. This test should be conducted in 2000, 3000, and 4000 Hz frequency ranges for both ears.
- Warning signs should be posted in areas where noise levels exceed 85 decibels, telling workers (and visitors) that the area is a "Mandatory Hearing Protection" area.
- Factories should keep records of noise monitoring results.

#### *Hazard Assessment*

- Noise levels within buildings should be monitored each year to determine which areas (if any) exceed 85 decibels.

- 
- Noise output on new equipment should be evaluated, and engineered controls should be used to reduce noise.

#### *Hazard Controls*

- Where noise levels are higher than 85 decibels, factories should provide workers with hearing protection, such as earplugs or earmuffs with a noise reduction ratio of 20. Workers should be trained and required to wear hearing protection.
- Where noise levels are higher than 85 decibels, factories should use engineered controls to reduce noise levels, including:
  - Rubber padding to reduce machine vibration
  - Sound barriers
  - Noise curtains
  - Sound-absorbing materials
  - Enclosures
  - Sound insulation
- Noise levels should not exceed a 140-decibel peak sound pressure level at any time.

---

## PERSONAL PROTECTIVE EQUIPMENT

### Purpose

**Personal protective equipment (e.g., safety glasses, ear plugs, safety shoes) is worn by workers to prevent or minimize exposure to workplace hazards. Personal protective equipment must only be considered as a hazard control measure after all practical engineering controls (e.g., enclosing equipment to make it quieter, installing ventilation equipment to remove air contaminants, etc.) and administrative controls (e.g., limiting the amount of time workers may do a task) have been used and there still remains a need for additional protection. The purpose of this section is to describe the requirements for the proper use of personal protective equipment.**

### Requirements

- IA** Factories must try to lower noise levels by properly maintaining equipment, installing rubber padding, etc. In areas where noise levels remain higher than 85 decibels, factories must supply workers with hearing protection (such as earplugs or earmuffs) that has a noise reduction ratio of 20. Workers must be trained to properly use the hearing protection and must be required to wear it. In addition, factories must designate these areas as “Mandatory Hearing Protection” areas by posting signs. (See the [Noise Management section](#).)
- IA** Factories should supply workers who do potentially hazardous work (e.g., drilling, sanding, grinding, construction, loading, or materials handling) with suitable personal protective equipment.
  - Factories should supply cutting room workers with metal mesh gloves, train workers to use them properly, and require that they be worn.
  - Workers should wear shoes or boots that will protect against foot injury.
  - Factories should provide workers with protective eyewear to guard against flying objects, glare (e.g., from laser usage), liquids, dust, etc. Prescription lenses typically do not provide enough protection. Eyewear should meet the applicable standard for impact resistance (see, for example, ANSI Z87.1-1989) and should not disturb the proper positioning of prescription lenses.
  - Sewing factories should provide finger guards for sewing workers to protect against needle punctures.
- CI** Factories should train these workers to use protective equipment properly and require that it be worn. Factories should inform workers about the health and safety risks of not wearing required personal protective equipment.
- CI** PPE storage areas should be kept clean, and factories should practice good housekeeping in these areas.

---

## Typical Personal Protective Equipment

- Eye protection such as safety glasses or goggles to guard against flying objects and dust.
- Face shields to protect against chemical or hot metal splashes, flying chips and sparks, heat and other hazards. These are often made of a heavy-duty plastic that is attached to a visor that should shield the entire face (and often shield the head and neck, as well).
- Hearing protection such as earmuffs and ear plugs for noise levels that exceed 85 decibels. ([See Noise Management section](#).)
- Head protection such as hard hats and bump/laceration caps. These protect against impact from falling, moving, flying objects and from knocking into objects. They also serve to protect workers from rain or other weather elements.
- Hand/Arm protection such as finger guards, thimbles, gloves, and sleeves. Fingers, hands, and arms should be protected from exposure to cuts, scratches, bruises, burns, and chemicals. Appropriate personal protective equipment should be used for the specific hazard.
- Aprons are worn to protect the body from chemical splashes.
- Foot protection such as safety shoes with guards designed to protect against impact, crushing injuries and punctures. Where acids, bases, lubricants, water, and other liquids are used, workers should wear slip-resistant and/or chemical-resistant shoes.
- Respiratory protection such as masks to protect against dust, and air-purifying respirators to protect against chemicals, dusts or vapors. The appropriate respirator type should be selected for the specific hazard, and it should be tested to make sure it fits the wearer. Medical exams and training should be completed before a worker may wear any respirator.

## Implementation of Requirements

### *Training, Rules and Record Keeping*

- Factories should choose suitable protective equipment for the hazards identified in the assessment (see “[Hazard Assessment](#)” below), provide workers with it, and require them to use it.
- Factories should train workers who are required to wear personal protective equipment on the following:
  - when the equipment is necessary,
  - what equipment is necessary (and required),
  - how to use and adjust the equipment,
  - limitations of the equipment, and
  - proper care and maintenance of the equipment.
- Factories should regularly review how well the personal protective equipment program is working and take action to improve it, if necessary.

### **Hazard Assessment**

- Factories should review and assess the workplace to identify hazards that require the use of personal protective equipment. ([See the Risk Assessment section.](#))

### **Hazard Controls – Sewing Factories**

- Operators should make sure that needle guards, eye shields, and machine guards are in place.
- Pressing and ironing operators should wear gloves, sleeves, and face shields (when appropriate) to protect against burns.
- Shoes with hard, non-slip soles should be worn to avoid puncture wounds from needles, pins, etc.
- While cutting fabric, workers should wear metal mesh gloves.

### **Hazard Controls – Laundry Facilities**

- Laundry facilities should make sure that operators of laser etching machines are provided with and required to wear laser safety glasses.
- Workers using chemicals and dyes should wear eye/face protection, gloves, and protective clothing such as aprons to protect them from chemical splashes.
- Laundry facilities should make sure there is adequate ventilation to protect workers from breathing toxic dusts or vapors. Respirators should be used only when an area cannot be ventilated properly.

### **Hazard Controls – Machine/Maintenance Shops**

- Workers should wear eye/face protection when drilling, sanding, grinding, welding, etc. to avoid contact with flying sparks, chips, and other objects.
- Mechanics should wear safety shoes to protect their feet from falling tools or heavy parts.
- When using (or cleaning up) any chemical, workers should follow the recommendations for personal protective equipment that are outlined on the Material Safety Data Sheet.

### **Hazard Controls – Shipping and Receiving**

- In areas where feet can be crushed by forklifts, carts, or dropped materials, workers should wear safety shoes.
- Leather or puncture-resistant gloves should be worn when handling pallets.

## **VENTILATION**

### **Purpose**

**The purpose of this section is to make sure that ventilation is used properly to remove air contaminants from the workplace to protect workers' health.**

### **Requirements**

- IA** Chemical mixing must take place in a well-ventilated or open area, using appropriate personal protective equipment.
- IA** Factories must use ventilation that directs air flow away from workers for tasks such as welding, or handling or mixing chemicals.
- IA** Ventilation system must be provided in abrasive-blasting workshop and spraying workshop.
  - Air flow is directed away from workers
  - Exhaust is directed away from air intakes
  - Exhaust is directed away from people living near the factory or other factories.
- CI** Ventilation system should be provided in all chemical storage areas.
- CI** Ventilation system should be checked and regularly maintained.

### **Implementation of Requirements**

#### **Hazard Assessment**

- Factories should periodically evaluate the ventilation system to check that it is working effectively.

#### **Hazard Controls – Sewing Factories**

- Factories should never discharge contaminated air flow close to (or at the same level as) a heating, ventilation, or air conditioning vent or an open area where exhausted fumes might be drawn back into the building through a make-up air unit, by fans, etc.
- In areas where friable asbestos-containing material is present, factories should never use forced ventilation or any ventilation that disrupts the asbestos-containing material. (See [Asbestos section](#) for the definition of “friable” and a description of the important role of a qualified contractor in evaluating workplace asbestos-containing material.)
- Factories should make sure that welding areas have a local exhaust ventilation system or forced ventilation to direct the air flow away from workers.

- Factory ventilation systems should use mechanical or electronic air filters to remove particles and activated charcoal filters to remove gases and vapors.

#### Further Information

- [See Finishing Safety Guidelines.](#)
- Guidance on selecting general and local exhaust ventilation systems is available at: [http://www.osha.gov/dts/osta/otm/otm\\_iii/otm\\_iii\\_3.html](http://www.osha.gov/dts/osta/otm/otm_iii/otm_iii_3.html).

## CHEMICAL MANAGEMENT

### Purpose

Chemical “handling” includes activities such as pouring or measuring chemicals, transporting chemicals within the factory, adding chemicals to equipment, and disposing of chemicals.

Safety measures, including the use of safety equipment, safe work practices and personal protective equipment (PPE), help workers avoid potentially hazardous exposures to chemicals. Proper storage of chemicals minimizes the risk of accidentally mixing incompatible chemicals. (For example, contact between a concentrated oxidizing acid and a flammable solvent would likely result in a fire or explosion.)

The purpose of this section is to describe the requirements for proper handling and storage of chemicals in order to protect worker health and safety, as well as factory equipment and building structures.

**Note:** *Chemical disposal is covered in the [Hazardous Waste topic](#).*

### Requirements

- IA** Factories must develop and implement a procedure for storing chemicals in an organized way, following guidelines for storage compatibilities ([see the Appendix](#)) to avoid contact between incompatible chemicals and providing for secondary containment, where necessary to prevent release to the environment.
- IA** Factories handling chemicals must have immediate access (within 10 seconds) to an eyewash station and shower that can be operated without the use of hands. Once an eyewash station is turned on, it must continue to flow without requiring a worker to operate it with his/her hands. Workers must have both hands available to hold open their eyes if they require a flushing.
- IA** Factories must meet legal requirements to notify government or other local agencies (such as fire departments) about chemicals used or stored onsite.
- IA** Chemical storage areas must have the following safety features:
  - Safety shower/eye wash nearby, within a 10 second walk
  - Spill kits with materials for containment and absorption
  - Fire-fighting equipment, fire hoses and/or fire extinguishers
  - Signs indicating PPE required to work in area
  - Secondary containment, with the capacity to hold 110% of the largest volume.
  - Aisles and forklift routes are clearly marked

- IA** Employees who work with chemicals must be provided with appropriate face and body protection (such as respirators, safety glasses, gloves or clothing) as specified in the SDS and training in proper chemical handling and emergency procedures. In addition, employees must be required to wear PPE if indicated by the SDS.
- IA** Chemicals and chemical containers must be disposed of properly and in accordance with all legal requirements.
- IA** All chemicals must be properly labeled in the language(s) spoken by workers. Violation may be rated (**CI**) if the factory has a good chemical management system in place and the violation is immediately corrected.
- IA** Chemicals must be stored and used in designated areas which are well ventilated.
- CI** Chemical storage areas should be kept clean, and factories should practice good housekeeping in these areas.
- CI** Safety Data Sheets should be kept on site, available in the language(s) spoken by workers, and should be available for review by workers

## Implementation of Requirements

### Training, Rules and Record Keeping

- The chemical inventory should be kept onsite and updated whenever a process is changed, and a new chemical is used and/or an existing chemical is no longer used and spill response procedures, and personal protective equipment. Factories should keep written records that show this training has been completed.
  - Training for workers who handle chemicals should cover the hazard and safety information provided in an SDS, the meaning of symbols on signs and labels, and ways to protect themselves from hazards, including proper chemical storage and the use of safety equipment, safe work practices, emergency.
- Signs written in the spoken language(s) of workers should be posted in the appropriate locations if PPE use is required. (See the Signs and Labels topic.) Signs prohibiting smoking should be posted in chemical storage areas. Chemical storage areas should also have signs that indicate the type of chemical stored there (e.g., corrosive, flammable, toxic, oxidizing substances).



**Good Practice: Chemicals stored in designated area. Area is clean and housekeeping is good.**

- Material Safety Data Sheets (SDS) for each chemical used at the factory should be kept on site and located so that workers have easy access to them.
- All containers, including secondary containers, must be labeled with the identity of the chemical(s) they contain and a brief warning phrase or symbol indicating the chemical's hazard(s) (e.g., "Caution—Flammable"). The NFPA 704 Hazard Identification diamond or the HMIG (Hazardous Material Information Guide) label are examples of labels that may be used to meet this requirement.

### Hazard Assessment

- Factories should assess chemical handling and storage areas to identify hazards and hazard controls (see the Risk Assessment topic). SDSs should be reviewed as a part of this process.
- Factories should routinely inspect areas where chemicals are stored and handled to make sure they meet the requirements.



**Good Practice: Proper signs and labels.**

### Hazard Controls – Sewing Factories

- Factories should identify and require appropriate PPE (such as respirators, safety glasses, gloves, or clothing) for workers who handle chemicals, based on the hazard assessment, the information contained in the SDS, and on local regulatory standards or other acceptable chemical exposure limits (see the Occupational Exposure Limit topic). See the Personal Protective Equipment topic for more information. If an air-purifying respirator is required for work with a specific chemical or chemicals, factories should ensure that workers are provided with the appropriate, protective respirator cartridges to match the chemical. The following web site provides information about cartridges appropriate for different types of chemicals:
  - <http://is.gd/blYnl> (3M Company Catalog)
- Factories should make first aid kits available in chemical handling areas. See the [First Aid](#) topic in the "Health Guidelines" section for more information.
- Factories should provide supplies and equipment for cleaning up chemical spills. These supplies should be located close to chemical handling and storage areas.
- Fire-fighting equipment, including a water hose and fire extinguisher, should be provided in chemical storage areas.

- Aisles and forklift routes should be clearly marked in chemical storage areas.
- Liquid propane gas tanks/cylinders, acetylene tanks, and chemical storage areas should be safely located away from sources of heat and flammable materials. In addition, they should be stored at a reasonable (safe) distance from workers.
- All outside chemical storage should be covered to protect steel drums from corrosion and to prevent plastic drums from deteriorating.
- Chemical gas cylinders should be stored in a well-ventilated area—preferably outside. They should be stored upright and secured (with chains) to a fixed object to prevent them from falling over. Gas cylinders should be stored away from ignition sources.
- Caps and lids on all chemical containers should be kept tightly closed to prevent evaporation of contents.
- Flammable storage cabinets should be used to store flammable liquids.
- Chemicals stored in amounts greater than 200 liters (~100 kg) should have secondary containment. (Secondary containment is a container or other structure outside the primary container that is used to keep chemicals from leaking onto building or equipment surfaces.) The secondary containment should be able to hold 110% of the largest stored chemical volume.
- Chemical containers should not be stacked any higher than three (3) meters. Chemical drums should always be stacked with the closure device upward. Drums should be stacked fewer than four (4) drums high, preferably with pallets between layers. Side-mounted drums should be chocked to prevent them from rolling.



**Good Practice: Secondary storage is segregated and well lighted.**



**Bad Practice IA: Secondary containment is too small for these chemical drums!**

## EXTREME TEMPERATURES

### Purpose

**Under extreme conditions of temperature, humidity, airflow, and workload, workers may experience heat or cold stress, which is the body's attempt to maintain a normal body temperature. Factory conditions that are very hot or very cold may cause workers to suffer from a variety of heat or cold stress symptoms, including heat cramps, heat exhaustion, heat rash, heat stroke, frostbite and hypothermia. Heat stroke (from extreme heat) and hypothermia (from extreme cold) are both conditions that may lead to death, if not treated immediately. The purpose of this section is to describe the requirements for safely working in extremely hot or cold temperature conditions.**

### Requirements

- IA** Proper personal protective equipment must be provided to workers who work in operations involving extreme heat or cold. Ovens and pressing machine are examples of operations that may require additional PPE.
- IA** Before a worker begins work in an extremely hot or cold job, a physical exam must be conducted to determine whether he/she is fit to work in such conditions.
- IA** Factories must have satisfactory temperature controls and must provide a working environment that does not routinely expose workers to excessive heat or cold.
- IA** Plenty of water must be available for workers who work in areas with high temperatures (near ovens, dryers, etc.).
- IA** Workers who work in extremely hot or cold job must be trained to recognize and respond to the symptoms of heat or cold stress.
- IA** Reasonable shifts and rest breaks planning must be taken into account the type of work (light, moderate, or heavy) and the temperature and humidity conditions.

### Implementation of Requirements

#### *Training, Rules and Record Keeping*

- Anyone who works around equipment or works in an area that may be extremely hot or cold should first be trained to recognize the symptoms of heat or cold stress and should be trained to respond to these symptoms. (Symptoms may include nausea, fatigue, dizziness,

confusion and irritability, among others). These workers should also be given five days to gradually adjust to conditions of extreme heat or cold.

- Workers should be trained to give first aid to other workers who may be showing stress symptoms from working in extremely hot or cold temperatures. Factories should keep written records to show that training has been completed.

### Hazard Assessment

- Make sure that thermometers are working properly.
- Evaluate whether a job scheduled to be done during an extremely hot or cold time of day can, instead, be done when the temperature is more comfortable.
- Plan rest breaks that take into account the type of work (light, moderate, or heavy) and the temperature and humidity conditions.
- Consider a worker's physical condition when determining his or her fitness to work in hot or cold environments.
- Before a worker begins work in an extremely hot or cold environment, make sure he/she has had a physical exam to determine whether he/she is fit to work in such conditions.

### Hazard Controls

- Make sure that equipment to control high or low temperatures is in place and working properly. This equipment may include ventilation, heaters, air conditioning, cooling fans, shields, and insulation.
- Make sure workers have personal protective equipment to protect against heat stress when they work around hot equipment (e.g., ovens, dryers, etc.) or to protect against cold stress when they work in cold temperatures.
- Allow new workers to have a five-day period



**Good Practice:** Typical fan used to cool workspace.

to adjust to extreme temperature conditions. Similarly, give this five-day adjustment period to

workers who have been away from work for two weeks or more.

- Workers should be allowed adequate recovery time when they are working in areas of extreme heat or cold. Rest breaks should take into account the type of work (light, moderate, or heavy) and the temperature and humidity conditions.
- Offer plenty of drinking water (as much as a quart per worker per hour) to reduce the risk of heat stress.
- Where there is a chance that workers will suffer heat stress caused by hot equipment, workers should wear clothing that reflects heat (aprons, jackets, suits, etc.). Any reflective clothing should be worn loose to allow air flow through it. Workers wearing such clothing

should be careful to avoid trapping it in machinery with moving parts.

## ASBESTOS MANAGEMENT

### Purpose

**Asbestos is a naturally occurring mineral that has been mined and used in numerous ways because it is fire resistant, chemical resistant, and a good insulator. Asbestos has been used in building materials such as floor and ceiling tiles, pipe insulation, sprayed fireproofing, roofing products, sealants, mastics, and gaskets. Asbestos fibers may be released into the air if the asbestos-containing material ages and starts to fall apart or if it is disturbed by sanding, sawing, or other activities. Some types of asbestos fibers, if they are released into the air, may enter the lungs and cause serious illness, including cancer. Exposure to asbestos fibers is especially hazardous for smokers. The purpose of this document is to provide guidance to reduce or avoid worker exposure to asbestos fibers in the air.**

### Requirements

- IA** Factories must have an asbestos management program and must work closely with a qualified contractor to:
  - train workers,
  - inspect building areas for asbestos-containing materials, and
  - create safe work practices, clean-up procedures, and a plan to prevent the release of asbestos into the air.

- IA** Factories must make a list of areas that are known to have or may have asbestos-containing materials.

- IA** Factories must review and comply with applicable asbestos laws and regulations.

- IA** Damaged building materials that may contain

asbestos must be sampled and tested by qualified consultants and laboratories to determine whether

they contain asbestos and what additional action is needed.

- CI** Maintenance workers should be trained to recognize materials that may contain asbestos.

- CI** Asbestos-containing materials should be properly marked. If a qualified contractor decides that it is not necessary to remove these materials, the factory should have a procedure to inspect them,



**Good Practice:** Asbestos-coated pipes are properly marked.



---

periodically, to make sure these materials remain in good condition.

**CI** If a qualified contractor finds that the asbestos-containing material contains “friable” asbestos ([defined in the Appendix](#)), a qualified contractor should repair, enclose, or remove the material according to applicable laws and regulations.

**CI** Factories should review purchases of new building materials to make sure they do not contain asbestos.

## Implementation of Requirements

### *Training, Rules and Record Keeping*

- Maintenance workers should receive asbestos training when they are hired and should be retrained each year after that.
- Factories should keep written records to show this training has been completed.
- A factory’s list of building areas that are known to have, or may have, asbestos-containing materials should include the location, description, and condition of all asbestos-containing materials.

### *Hazard Assessment*

- All areas of the factory building (e.g., mechanical areas, common areas, work areas, laundries, kitchen) should be inspected for asbestos-containing materials. Both friable and non-friable asbestos-containing materials should be identified.
- Each year, the physical condition of any asbestos-containing materials should be evaluated, and any changes should be noted and included on the list referred to in the [Training, Rules, and Record Keeping section](#).

### *Hazard Controls*

- Factories should establish procedures to ensure that workers and work practices do not damage or disturb asbestos- containing materials, which might release asbestos fibers into the air.
- Signs should be posted to indicate the location of asbestos- containing materials.
- All asbestos waste should be labeled before disposal.
- Containers used to dispose of asbestos waste should be properly sealed.

## OCCUPATIONAL EXPOSURE

### Background

Workers may be exposed to chemicals in the workplace by, for example, inhalation or skin contact. Government agencies (such as the United States Occupational Safety and Health Administration, OSHA), and other organizations (such as the American Conference of Governmental Industrial Hygienists, ACGIH) have published limits to protect workers from adverse effects which may occur from excessive exposure to certain chemicals. These limits are often referred to as “occupational exposure limits” (OELs) and are referenced in Safety Data Sheets (SDS, previously known as Material Safety Data Sheets (MSDS)). The nature of the work varies from factory to factory and may change within a factory during the course a typical year. If any of the chemicals listed below, or any other chemicals, are used in the factory, industrial hygiene monitoring (which measures chemical exposure) shall be used to determine whether exposure is in conformance with the applicable OEL.

Industrial hygiene monitoring, which measures chemical exposures, shall be used to determine whether exposures are acceptable or whether they exceed the local legislation limits or available standard, or OSHA listed OELs.

### Purpose

The purpose of this section is to emphasize the factory’s obligation to ensure compliance with all applicable OELs and to conduct and pay for industrial hygiene monitoring. The contracting factory shall obtain sufficient analytical information regarding its workplace so that factory management can better ensure that no one in the workplace suffers injury or occupational illness. Factory shall comply with OELs set by local authorities or, in case local regulation does not exist, factory shall use the best available standard.

### Requirements

**IA+** Factory shall comply with the OELs listed in this section or with those set by local authorities, whichever are more stringent. Regardless of whether it is listed below, if there is potential for worker exposure in excess of the applicable OEL, factory shall conduct appropriate industrial hygiene monitoring.

**IA** Factory shall continually review tasks, operations and conditions to determine whether the nature of the work involves exposure to chemicals and, if so, include those chemicals in an industrial hygiene monitoring plan and monitor annually. Factory must recognize that processes may change, thereby bringing into play new chemicals for which representative industrial hygiene monitoring has not been conducted at the factory (in which event industrial hygiene monitoring must be conducted).

**IA** Factory shall use qualified industrial hygienists to conduct industrial hygiene monitoring under worst-case conditions (e.g. maximum workload) and use qualified laboratories to analyze and report on the samples. The names and contact information for the industrial hygienists and laboratories, and the results of the industrial hygiene monitoring shall be provided to SCOC assessor.

**IA** Factory shall make available for the industrial hygienist all required information such as all MSDS/SDS which have been received. These materials shall be kept for evidence.

**IA** Factory shall perform annual industrial hygiene monitoring assessment for SCOC approval - as a minimum - for the following substances if they are used at the factory in any of the activities listed below:

**Footwear Occupational Safety**

- Assembling, curing
  - Benzene
  - n-Hexane
  - Ethyl acetate
  - Methyl ethyl ketone
  - Toluene
  - Others if identified on SDS
- Cutting and Brushing
  - Respirable leather dust

**Apparel Occupational Safety**

- Cutting, hand scraping, brushing and damaging
  - Respirable dust
- Spraying
  - Manganese
  - Formaldehyde
- Dipping/sponging
  - Formaldehyde
  - Manganese
- Oven curing
  - Formaldehyde

- Solar curing
  - Formaldehyde
- Ozone depletion
  - Ozone
- Cryonomic treatment
  - CO2
- Screen printing
- Formaldehyde
  - Brushing
- Respirable dust
  - Chemical storage
- SDS to be reviewed

**IA** If personal air monitoring discovers employee exposure at or above 10% of the 8-hour TWA, the involved factory must repeat processes at least once a year under worst- case conditions (potential conditions that would be expected to lead to the highest worker exposures).

**IA** Each factory shall also measure employee exposures promptly, upon receiving reports of complaints from workers or symptoms related to specific substance. The factory shall inform the SCOC assessor of any such report or complaint.

**IA** Factory shall establish a procedure to reduce chemical exposures to ensure compliance with the applicable OEL, must the industrial hygiene monitoring results indicate this is necessary. This procedure shall include effective application of engineering controls work practices and/or personal protective equipment. Once controls have been implemented, factories must re-evaluate exposures to determine whether the controls have reduced worker exposures below the applicable OEL.

**Implementation of Requirements**

**Hazard Controls**

**IA+** Factory shall identify and require appropriate PPE (such as respirators, safety glasses, gloves, or clothing) for workers who may have exposures to chemicals above the occupational exposure limits. See the Personal Protective Equipment topic for more information. Factories must evaluate the use of engineering controls (such as improved ventilation) as well as work practices (e.g., limiting the amount of time employees work with a chemical) to reduce chemical exposure levels below the OELs.

**Training, Rules and Record Keeping**

**CI** Industrial hygiene monitoring results shall be disclosed to workers and reports made available on request to the SCOC Assessor. Factories should archive hygienic reports for 40 years, or as specified in the local legislation, whichever prevails.

**Hazard Assessment**

**CI** Factory shall establish a plan to conduct industrial hygiene monitoring that includes steps to (1) identify which chemicals it uses that also have OELs (most commonly- used chemicals do); (2) evaluate tasks and conditions in which those chemicals are used; and (3) prioritize chemicals for industrial hygiene monitoring. Evaluations of tasks and conditions should consider the manner in which the chemicals are used (e.g., potential for vapors or for splashing), the controls already in place (such as ventilation), and the duration and frequency with which workers use the chemicals.

**CI** The industrial hygiene monitoring plan should be updated periodically, based on changes to the chemical inventory and the results of previous industrial hygiene monitoring.

---

## SIGNS AND LABELS

### Purpose

The purpose of this section is to make sure that factories properly communicate work area hazards and chemical hazards by posting the appropriate signs and labels. The Appendix provides examples of internationally recognized safety and warning signs and symbols.

### Requirements

- CI** Factories should establish a procedure for using signs and labels to communicate workplace hazards.
- CI** Workers should be trained to recognize and understand the meaning of the hazard warning signs and labels in use at the factory.
- CI** Factories should routinely inspect all signs and labels to make sure they (a) are in place and (b) are maintained in good condition, visible, and functioning as intended.
- CI** Factories should ensure there are an adequate number of signs and labels to communicate hazards. In addition, signs and labels should be:
  - Displayed clearly
  - Large enough to be visible to those intended to see them
  - Written in a language (s) that can be understood by all workers
  - Constructed so they resist corrosion and weather effects
- CI** Essential signs (such as emergency exits) should be illuminated so they are visible when it is dark or foggy, or if there is smoke. These signs should be properly maintained, replaced and/or removed as necessary or when no longer valid.

### Implementation of Requirements

#### *Training, Rules and Record Keeping*

- Workers should be trained to recognize and understand the hazard warnings provided by signs and labels. Factories should keep written records of such training.
- Factories should make and keep a list of the areas and equipment that require signs and labels. Include the specific location, the type of equipment (including chemical containers), and the type and numbers of signs and labels.

### *Hazard Assessment*

- Factories should review the hazards in each work area to make sure that signs and labels are being used correctly to warn workers of these hazards. (Also [see the Risk Assessment topic.](#))
- Building areas should be inspected each month to make sure signs and labels are in place, displayed clearly and well maintained.
- Factories should periodically request input from workers and management about the effectiveness of the signs and labels in work areas.

### *Hazard Controls – Printing Workshop, Laundry Workshop & Chemical Warehouse*

- Post warning signs and labels in these areas.
- Provide signs and labels that provide specific safety instructions for the chemicals that workers handle.
- Provide signs requiring workers to use the proper PPE.

### *Hazard Controls – Cutting Workshop*

- Provide signs requiring workers to wear the proper PPE (such as metal gloves and dust-protective masks).

### *Hazard Controls – Sewing and Dry-Finishing Workshop*

- Provide signs requiring sewing workers to use eye guards and needle guards on their machines.
- Provide signs requiring workers to use hand-protection devices on the button-punching machines.
- Ensure that chemicals are properly labeled and provide signs instructing spot-cleaning workers on how to use them safely.
- Provide signs requiring workers to use proper PPE.

### *Hazard Controls – Generator Workshop, Embroidery Workshop & Boiler Workshop*

- Post signs warning workers that hearing protection is required in these areas.
- Post signs indicating these are restricted areas and that workers should be authorized to enter them.

### *Hazard Controls – Wastewater Treatment Plant*

- Post signs indicating this is a restricted area and that only authorized workers may enter it.
- Ensure that chemicals are properly labeled and provide signs instructing workers on how to safely use them.
- Provide signs requiring workers to use proper PPE.

---

## MAINTENANCE

### Purpose

**Maintenance is a set of organized activities that are carried out to keep factory buildings and equipment in safe and effective operational condition. The purpose of this section is to make sure that maintenance-related activities, whether they are performed by internal maintenance teams or external contractors, are performed safely. The main objectives are to keep the workplace and its structures, equipment, machines, furniture, and facilities operating properly and safely.**

### Requirements

- IA+** Specialized maintenance tasks can be performed only by authorized and skilled personnel.
- IA** Maintenance teams are provided with appropriate information regarding any risk that is associated with their tasks.
- IA** Maintenance teams prepare and follow appropriate procedures to address whatever risk is associated with their tasks and are fully trained regarding those procedures.
- IA** External contractors prepare and follow appropriate procedures to address whatever risk is associated with their tasks, being sure to comply with the most stringent applicable safety standards.

### Implementation of Requirements

- IA** Maintenance work can be complex and difficult and involve diverse circumstances. The recommended approach is to establish two maintenance groups: building maintenance (the preventive and remedial upkeep of building components such as (HVAC, electrical, plumbing, elevators, carpentry and painting), and equipment maintenance (equipment related to the manufacturing process).

### Risk assessment and safety working procedures associated with the task

- IA** An assessment of risk must be prepared for each maintenance task, and that assessment must be provided to and understood by all maintenance workers.
- IA** Safe working methods, including safety checklists and inspection frequency, must be specified for all maintenance tasks

- 
- IA** Non-exhaustive list of procedures expected to be implemented in suppliers' premises: roles and responsibilities, training and communication, prevention of alcohol and drugs, work at heights, electricity, machinery, external contractors, raking systems, work in confined spaces, use of personal protective equipment, asbestos, lock-out & tag-out, chemicals storage and management, workshop equipment, welding, hazardous waste management, manual handling, and forklift trucks.

### *Training, Rules, and Record Keeping*

- IA** Employees involved in maintenance must be trained to identify hazards, assess their risks, and evaluate the effectiveness of control measures.
- IA** Close supervision and enforcement are essential to achieve a fully safe environment, and it is the responsibility of all employees to promptly report any condition or behavior that they believe to be unsafe.
- IA** Training and education must account for process and technological change.

# Finishing Guidelines



## FINISHING SAFETY GUIDELINES

### Application

The finishing safety guidelines apply to all factories that finish/laundry garments for Levi Strauss & Co. using any of the following processes.

### Background

The finishing of garments involves a variety of physical and chemical processes that give garments a desired appearance (e.g., faded, tinted, vintage) or quality (e.g., wrinkles, whiskers, water repellent, stain repellent).

### Purpose

The purpose of this section is to ensure that factories have controls in place to protect employees who are involved with the finishing process. Finishing factories are required to meet all of the following requirements for each of the listed processes undertaken at the factory:

The following processes are covered in this section:

- **Hand scraping** is a process of manual abrasion of fabric or garment by hand using abrasive paper (also called sand paper or emery paper) or power tools. This process imparts a distressed or worn-out look to the denim garment. Hand scraping includes, but is not limited to, scraping, handwork, and whiskering.
- **Laser Etching** uses a laser beam that burns away the blue coloring, thus producing a faded look or creating patterns such as lines, dots, text, or even pictures on a garment.
- **Curing and drying** is the process of heating the garment in a hot air-circulated oven (electrical, steam, oil or gas-fired, solar lamps) for a pre-set period of time at a defined temperature.
- **Dipping and sponging** involve applying a potassium permanganate solution or other bleaching agents with a sponge or by dipping the garment to achieve tints, bleach, or color effects on the garment.
- **Ozone treatment** involves treatment of the garment with ozone to create a bleached effect or create a 'greyish cast' on washed denim garments to give them a worn-out look.

- **Resin treatment** is the application of a chemical resin solution by spray or dip method, followed by a curing process in a batch or continuous manner using a flasher or a continuous curing chamber. The process creates creases (3D effect) at specific places on the garment that are fast even after multiple home launderings. Effects such as contrast effect, cloudy effect and vintage look can be obtained by the dip method.
- **Panel or Screen Printing** is a process in which inks (pigments and print base) are mechanically applied to a garment to produce a design or logo. The print is then dried and cured under heat.
- **Spraying** involves applying potassium permanganate solution through a hand spray gun for bleach effects on denim garments. This process is also used for tinting garments with pigments at localized areas.

## HAND SCRAPING

### Background

**Hand scraping is a process involving manual abrasion of the fabric or garment, using abrasive paper (also called emery paper) or electrical/pneumatic abrasive power tools. This process imparts a ‘distressed’ or ‘worn-out’ look to the denim garment. Hand scraping includes also whisker/moustache and all other manual abrasive effects.**

### Purpose

**The purpose of this section is to provide health and safety guidance for workers conducting hand scraping.**

### Potential EHS Issues

1. **Scraping can generate airborne dust (e.g., from emery paper particles) which may include tiny fibers/lint which in turn can become a respiratory issue.**
2. **The use of an abrasive power tool can cause physical injury.**
3. **Improper ergonomic design or set-up of the work station or the equipment can lead to musculoskeletal disorders for workers.**

### Requirements

#### *Abrasive paper*

**ZTV** The Safety Data Sheet for each abrasive paper must be carefully reviewed by each worker conducting hand scraping, and the abrasive paper must be free of crystalline silica and asbestos.

**IA+** The worker shall not use an abrasive paper unless the Safety Data Sheet for that abrasive paper states that the only abrasive materials present are:

- |                         |                           |                       |                        |
|-------------------------|---------------------------|-----------------------|------------------------|
| • aluminum oxide        | • cryogenic polycarbonate | • polycarbonate       | • urea plastic         |
| • aluminum shot         | • emery                   | • silicon carbide     | • walnut shells        |
| • ambient polycarbonate | • garnet                  | • stainless cast shot | • wheat grain          |
| • apricot pits          | • glass beads             | • stainless cut wire  | • white aluminum oxide |
| • corn cobs             | • melamine plastic        | • steel grit          | • zircon               |
|                         | • novaculite              | • steel shot          |                        |

## Personal Protective Equipment

- IA+** When mechanical tools are in use, safety glasses and protective gloves shall be worn.
- IA+** The Industrial Hygiene section of the LS&Co. Sustainability Guidebook shall be reviewed to identify whether PPE use is needed (e.g., for hearing and inhalation protection) and PPE must be provided accordingly.
- IA** A hand/body washing facility shall be accessible to workers at all times.

## Housekeeping

- IA** Workers must be instructed to clean the work area regularly and carefully and to direct particles away from other workers while cleaning.
- IA** The work room must have sufficient ventilation to reduce airborne dust particles and provide sufficient balanced air exchange.
- IA** Power tools must regularly be cleaned, maintained and inspected.
- IA** Regular and scheduled clean-up and housekeeping must include high ceiling pipes, lighting armatures and all other areas in the workplace.

## Ergonomics

- IA+** Periodically conduct general medical tests for workers for respiratory health.
- IA** The vertical mannequin shall be positioned between the standing worker's elbow and shoulder and the horizontal mannequin shall be positioned between the standing worker's waist and elbow.
- IA** Periodic rest breaks are required.
- IA** Standing operators shall be encouraged to sit during rest breaks.
- IA** Training must be provided to all workers regarding proper hand scraping practices, and written records of such training must be prepared and retained.

## LASER ENGRAVING

### Background

**A laser is a highly intense beam applied on a garment to fade dyes, giving the garment a worn and abraded appearance. The laser beam is focused through a lens producing the faded look or creating patterns such as lines, dots, text or even pictures on a garment.**

### Purpose

**The purpose of this section is to provide health and safety guidance for workers conducting laser operations**

### Potential EHS Issues

- 1. Electrocution from improper use of lasers associated with high voltage.**
- 2. Permanent eye injury from exposure of eyes to highly concentrated energy emitted from lasers and reflections.**
- 3. Skin injury from acute exposure or direct contact with the laser beam or specular reflections.**
- 4. Inhalation of fumes generated by laser energy**
- 5. Fire due to the high energy and temperature associated with the laser process.**

### Requirements

#### Engineering Controls

- IA+** Physical barriers must be in place to prevent a worker from being hit by moving parts of the machine.
- IA+** An Emergency Stop must be provided and must be easily accessible.
- IA** The laser must have a protective housing with appropriate interlocked controls to prevent unauthorized personnel or accidental entry to the area where the laser is in operation.
- IA** The factory must ensure that the laser machine is protected from unauthorized use.
- IA** Fire extinguishers shall be installed where laser operations are being conducted and operators shall be trained on their proper use.
- IA** Factory shall ensure that exhaust ventilation removes fumes from the working area.



- IA** The factory shall have on site a trained and authorized laser machine maintenance technician.
- IA** Remove inflammable or combustible gases, liquids, or solids that can be ignited by the radiation from the laser beam.
- IA** Some materials, such as metals or plastics, can release toxic decomposition products when treated with a laser beam. Investigate the hazards associated with the materials that have to be processed. This kind of information can be obtained from the material supplier.
- IA** Make sure that all objects which may reflect the laser beam accidentally are removed from the laser area.
- IA** The working zone shall be shielded, for example, for CO2 laser with acrylic or polycarbonate.
- IA** The laser beam must never be turned on without a target (garment) to absorb the energy.
- IA** For fire safety precautions, do not attempt to treat a material with a laser beam unless the heating characteristics of the material have been investigated thoroughly and fully understood.
- IA** The area around the laser and its power sources must be kept dry.

#### ***Administrative controls***

- IA** Only trained personnel shall be permitted to operate laser equipment.
- IA** The factory shall maintain and operate laser systems as per the manufacturer's recommendations.
- IA** Laser equipment or machines, when not in use, must be switched off.
- IA** For the table- type laser machine, the operator must not wear any rings, metallic watchbands and other metallic objects.

#### ***Warning Signs and Labelling Requirements***

- IA** All access doors to rooms that house laser equipment shall be posted with a signboard having the laser symbol (sunburst). Be sure all employees know what the sunburst signifies.

- IA** The laser health and safety requirements and the laser machine operation manual shall always be kept near the laser machine and available to operators for review.

#### ***Personal Protective Equipment***

- IA** Safety glasses which are specifically designed for protection against the emitted wavelength of the laser shall be provided (regular glasses do not give protection) and kept in good condition.
- IA** If not identified in the laser machine operator's manual, the factory shall contact the laser machine manufacturer to select the correct type of safety glasses used by the factory's laser machine operators.

---

## SPRAYING

### Background

Spraying involves applying potassium permanganate solution, bleaching agents, or tints through a hand spray gun for bleach or color effects on denim garments.

Tinting in denim garments involves spraying pigments along with requisite amount of binder and acid catalyst on the desired area of the garment to achieve a particular cast. After application, the tints are cured to create a permanent effect on the garment (please refer to the [curing section](#)).

Resin treatment can be carried out on a garment by spraying. The resin is then fixed by a batch curing process, solar lamps, or a continuous curing chamber to produce a coating on the garment that imparts the desired effect or property (e.g., creases; 3D effect).

### Purpose

The purpose of this section is to provide health and safety guidance for workers conducting spraying operations.

### Potential EHS Issues

1. Certain substances may spread throughout the workplace during spray application and can result in respiratory issues and/or skin irritation.
2. Chemical droplets can cause eye irritation.
3. Noise from the use of high-pressure tools involved in spraying.
4. Chemical build-up on the different parts of the system can result in fire
5. Some types of pneumatic spraying systems can explode if proper maintenance and cleaning are not carried out
6. Improper ergonomic design or set-up of the workstation or the equipment can cause musculoskeletal disorders (MSD).
7. Spray particles and wastewater discharge can cause environmental exposure as certain substances can be harmful for the environment.

---

## Requirements

***The following control measures must be in place:***

- IA+** Provide adequate ventilation in the work area.
- IA+** Factory shall regularly check the cleanliness of the exhaust pipes and fans to address fire risk and keep sufficient exhaust ventilation flow.
- IA** The factory shall ensure that workers are protected adequately from chemicals during application by spraying.
- IA** The Industrial Hygiene section of the LS&Co. Sustainability Guidebook shall be reviewed to identify whether PPE is needed (e.g., for hearing and inhalation protection).
- IA** The factory shall provide work wear for workers working in the spraying operation. A hand/body washing facility shall be accessible to workers at all times.
- Solutions required for the spraying process must be mixed in a well-ventilated area.
- IA** The Chemical Management section of the LS&Co. Sustainability Guidebook shall be followed in all respects, including the proper storage of spraying chemicals.
- IA** All Safety Data Sheets for chemicals used in the process shall be made known to workers, be readily available, and be carefully read by the workers to ensure that adequate protections and precautions are taken (e.g.: ventilation, PPE).
- IA** A safety shower and eye wash facility shall be available where chemicals are applied.
- IA** Adequate safety gloves shall be used as specified by the Safety Data Sheet or as otherwise required by the work conditions (sharp objects, long enough for the process, etc.).
- IA** The factory shall provide safety glasses for spray operation as required in the Safety Data Sheet.
- IA** Fire extinguishers shall be readily available where spraying operations are conducted, and spraying operators shall be trained on their proper use.
- IA** The factory shall make sure that all containers and jars are properly labeled, including warning signs regarding chemical content and associated hazards.
- IA** The factory shall allow only trained personnel to operate spraying equipment.

- 
- IA** Periodically conduct medical tests for workers who handle spraying chemicals.
  - IA** The vertical mannequin shall be positioned between the standing worker's elbow and shoulder, and the horizontal mannequin shall be positioned between the standing worker's waist and elbow.
  - IA** Periodic rest breaks are required.
  - IA** Standing operators shall be encouraged to sit during rest breaks.
  - IA** Factory shall ensure that air and water emissions from the spray operations are filtered to avoid environmental pollution.

---

## CURING

### Background

**Drying and curing is the process of heating the garment in a hot air-circulated oven (electrical, steam, oil or gas-fired, solar lamps) for a pre-set period of time at a defined temperature.**

### Purpose

**The purpose of this section is to provide health and safety guidance for workers involved in the curing process.**

### Potential EHS Issues

- 1. Certain substances used during the curing process can result in respiratory issues and/or skin irritation.**
- 2. Hot surface in curing can burn skin.**
- 3. High temperature in the working environment.**
- 4. Fire is possible because of the high temperature in the curing process.**
- 5. Explosion is possible due to improper use of fuel gas/oil or due to increased pressure in a closed and poorly ventilated chamber.**
- 6. Air pollution can cause environmental exposure as certain substances can be harmful to the environment.**

### Requirements

- IA+** An Emergency Stop must be provided and must be easily accessible.
- IA+** Factory shall ensure that batch type curing machine has an escape exit installed.
- IA+** Factory shall ensure adequate ventilation in the curing area.
- IA** Factory shall ensure that hot parts of the curing oven are highlighted/signed.
- IA** Factory shall ensure that exhaust ventilation eliminates fumes from the work area of the curing process
- IA** Factory shall regularly check the cleanness of the exhaust pipes and fans to address fire risk and keep sufficient exhaust ventilation flow.

- 
- IA** Fire extinguishers shall be available in areas where curing operations are being conducted and operators shall be trained in their proper use
  - IA** The factory shall ensure proper gloves are worn to protect hands from hot parts of the machine and hangers.
  - IA** The Industrial Hygiene section of the LS&Co. Sustainability Guidebook shall be reviewed to identify whether PPE use is needed (e.g., for inhalation protection) and PPE must be provided accordingly.
  - IA** Regarding oil or gas-fired curing chambers, the gas burner shall be checked regularly for health, safety, and environmental protection by specialized personnel.
  - IA** The factory shall provide adequate safety glasses for solar curing operation if these are identified in the manual. If not, contact the solar manufacturer for advice.
  - IA** Flammable or combustible gases, liquids or solids can be ignited by the radiation from the curing process. Remove all these materials from the curing area.
  - IA** The factory shall allow only trained personnel to operate of curing equipment.
  - IA** Data-logging equipment must be used to verify the actual temperature of the garment being cured in the chamber. This ultimately prevents the overheating of garments and protects against fire risk.
  - IA** Factories shall ensure a periodic maintenance plan for ovens, and all critical operations controls shall be checked during the maintenance activity.

---

## DIPPING AND SPONGING

### Background

**Dipping and sponging involve applying potassium permanganate solution or other bleaching agents with a sponge or by dipping the garment to achieve tints, bleach, or color effects on the garment.**

**Tinting in denim garments is done by sponging pigments along with the requisite amount of binder and acid catalyst on the desired area of the garment to achieve a particular cast. After application, the tints are cured to achieve a permanent effect on the garment (please refer to the [curing section](#)).**

### Purpose

**The purpose of this section is to provide health and safety guidance for workers involved in sponging and dipping operations.**

### Potential EHS Issues

- 1. Certain substances employed during sponging or dipping can result in respiratory issues and/or skin irritation.**
- 2. Chemical droplets can cause eye irritation.**
- 3. Improper ergonomic design or set-up of the workstation or the equipment can cause musculoskeletal disorders.**

### Requirements

***The following control measures must be in place:***

- IA+** Factory shall provide adequate ventilation in the work area.
- IA** The Industrial Hygiene section of the LS&Co. Sustainability Guidebook shall be reviewed to identify whether PPE use is needed for inhalation protection. PPE must be provided accordingly.
- IA** Factory shall provide work wear for workers working in the sponging and dipping operation.
- IA** A hand/body washing facility shall be accessible to sponging and dipping workers at all times.
- IA** Solutions required for the sponging or dipping process must be mixed in a well-ventilated area.

- IA** The Chemical Management section of the LS&Co. Sustainability Guidebook shall be followed in all respects, including regarding proper storage of the sponging or dipping chemicals.
- IA** All Safety Data Sheets (SDS) of chemicals used in the process shall be available and analyzed to ensure that adequate protections and precautions are taken (e.g. ventilation, gloves, mask, etc.).
- IA** A safety shower and eye wash facility shall be available where chemicals are applied.
- IA** Factory shall make sure that all containers and jars are properly labeled, including warning signs of the chemical content and associated hazards.
- IA** The factory shall allow only trained personnel for the operation of sponging or dipping.
- IA** Periodically conducts medical tests for workers that perform sponging or dipping operations.
- IA** Standing operators shall be encouraged to sit during rest breaks.

## SCREEN PRINTING

### Background

Screen printing is a process in which inks (pigments and print base) are mechanically applied to a garment. This process is used for the application of a design or logo onto garments. After application of the ink, the print is dried and cured using a tunnel-type curing oven, hot press, flasher, or similar equipment at elevated temperatures.

Different kinds of print bases are available for screen printing:

- PVC based (platisol)
- Phthalate – free
- Water based (acrylic acid)
- Silicone based

### Purpose

The purpose of this section is to provide health and safety guidance for workers involved in screen-printing operations.

### Potential EHS Issues

- Certain substances used during screen printing can result in respiratory issues and/or skin irritation.
- Chemical droplets can cause eye irritation.
- Hot surface of curing technique can cause skin burning
- Curing process can cause fire hazards due to the high-temperature process
- Rotating parts can cause injury

### Requirements

**The following control measures must be in place:**

- IA** The Industrial Hygiene section of the LS&Co. Sustainability Guidebook shall be followed to identify whether PPE use is needed for inhalation protection. If so, provide PPE accordingly.
- IA** Factory shall provide work wear for workers working in the screen-printing operation.

- IA** The factory shall provide workers with an accessible hand/body washing facility at all times.
- IA** Solutions required for the paste preparation must be carried out in a well-ventilated area.
- IA** The Chemical Management section of the LS&Co. Sustainability Guidebook shall be followed to properly store the printing chemicals.
- IA** The factory shall provide adequate ventilation in the work area.
- IA** The factory shall ensure that exhaust ventilation eliminates curing fumes from the work area of the curing process to avoid exposure to workers.
- IA** All Safety Data Sheets (SDS) for chemicals used in the process shall be available and analyzed to ensure that adequate protections and precautions are taken (e.g., ventilation, gloves, mask, etc.).
- IA** A safety shower and eye wash facility shall be available where chemicals are applied.
- IA** The factory shall make sure that all containers and jars are properly labeled, including warning signs regarding the chemical content and associated hazards.
- IA** The factory shall allow only trained personnel to operate the screen printing. Periodically
- IA** conduct medical tests for workers that perform screen printing operations. Standing
- IA** operators shall be encouraged to sit during rest breaks.
- IA** The factory shall make sure that hot parts of the curing oven are highlighted/signed.
- IA** Fire extinguishers shall be placed in the area of the curing machine, and operators shall be trained for their proper use.
- IA** Flammable or combustible gases, liquids, or solids that can be ignited by the radiation from the curing process shall be removed from the curing area.

## ABRASIVE BLASTING

### Purpose

**Levi Strauss & Co. has implemented a global ban on abrasive blasting. As of September 8, 2010, LS&Co. stopped placing new orders for sandblasted products and as of December 31, 2010, LS&Co. no longer had any active production that uses this finishing technique.**

### Requirements

**ZTV** LS&Co. bans all forms of abrasive blasting including, but not limited to, the use of aluminum oxide, aluminum silicate, silicon carbide, copper slag and garnet. LS&Co. suppliers must remove all equipment and abrasive materials from their manufacturing site.

## OZONE

### Application

This information applies to all factories covered by the Sustainability program for Levi Strauss & Co.

### Background

Some factories use ozone as a bleaching agent in the fabric or garment finishing process. Ozone generators use an electrical current to charge oxygen molecules in the incoming air and produce ozone. Ozone is an irritant gas and may cause health effects that range from irritation of the eyes, nose, throat and chest to severe injury. Ozone is also a strong oxidizing agent and may pose a fire or explosion hazard under certain circumstances.

### Purpose

The purpose of this section is to explain the safety requirements for ozone generators and associated equipment to prevent accidents, injuries, and/or illnesses that could result from exposure to ozone gas. The requirements set out below shall be followed for each ozone finishing installation at each manufacturing facility to achieve the LS&Co. required 3-level safety: 1, isolation; 2, ventilation; 3, detection.

### Requirements

#### Ozone Generator Safety

- IA+** The ozone generator room shall have exhaust ventilation linked to the outside.
- IA+** Factory shall equip areas in which ozone generators are located with an ozone monitor and an audible and visual alarm that will alert if the ozone level exceeds 0.3 ppm.
- IA+** The ozone generator shall have at least 2 shut-off switches:
  - On the generator
  - Outside of the ozone-enclosed area
- IA** Factory shall isolate ozone generators from the rest of the factory by enclosing them in their own room by using a physical cover (e.g. brick, glass or polycarbonate walls, etc.).

- IA** Equipment associated with the ozone generator (such as pipes, pipe connectors, and clamps) shall be made of ozone-resistant materials and must be strong enough to withstand the pressure generated by the ozone finish process.
- IA** Connection pipes between the generator room and ozone treatment equipment shall be enclosed through the use of a rigid tube/channel for physical protection.
- IA** All sensors in the system shall be kept switched on at all times when the ozone generator is in operation (e.g., if the generator is supplying only one washer out of several, sensors should not be turned off on any machine).

#### Ozone Finishing Equipment Safety

- IA+** The ozone Finishing Machine room shall have exhaust ventilation linked to outside to suck air away from the work area. The ventilation can stop only if the whole installation is switched off (all generators and washers).
- IA+** Ozone concentration inside the ozone chamber shall be monitored to ensure the machine is locked until the ozone is at or below 0.2 ppm.
- IA+** Factory shall also install an ozone monitor and audible and visual alarm close to the washer door to alert for immediate evacuation from that area if ozone levels exceed 0.3 ppm.
- IA+** Second door and dosing system on washer shall have automatic lock so it cannot be opened.
- IA** Factory shall isolate ozone equipment (except vacuum-type machine) from the rest of the factory by enclosing it in a separate room by using a physical cover (e.g. brick, glass, or polycarbonate walls, etc).
- IA** Factory shall isolate integrated ozone equipment (when washer and generator built in one piece) from the rest of the factory by enclosing it in a separate room by using a physical cover (e.g. brick, glass or polycarbonate walls...etc.).
- IA** Negative pressure ozone finishing machine shall be equipped with an exhaust ventilation to maintain constant negative pressure inside the machine. The ventilation can stop only if the whole installation is switched off (all generators and washers).
- IA** The control panel of the ozone machine shall be visible from outside the ozone machine room (or be installed outside), and the factory shall make sure that the operator is not staying inside the room during the ozone treatment process.
- IA** Excess or exhaust ozone shall be ventilated through an ozone-destruct unit. The ozone-destruct unit may use either thermal/steam or catalytic conversion technology and must

destroy ozone.

**IA** Final discharge after destruction shall go through a vertical chimney high enough to avoid human exposure.

**IA** Final discharge after destructor to the environment shall be monitored to identify when destructor needs to be maintained and to verify that the unit is capable of destroying the amount of ozone moving through it.

**IA** Pipes, connectors, sealants, and clamps shall be made of ozone-resistant materials (e.g., stainless steel connectors for tubing). Note: This is applicable for all parts.

**IA** Factory shall evaluate the ozone exposures of workers on a regular basis by performing an official work environmental survey.

**IA** Flammable or combustible materials shall not be stored in the same room as the ozone generator.

**IA** Factory shall have at least one Self-Contained Breathing Apparatus (SCBA) available for emergency use.

**IA** Factory shall have an air-purifying, full-face piece respirator (gas mask) with a chin-style, front or back-mounted canister providing protection against ozone. Only monoxidizable sorbents are allowed (not charcoal)



**Full-face piece respirator (gas mask) with a chin-style front or back mounted canister for escape**

**IA** The safety features of the machine, including the computer program, shall be protected and modified only with the agreement of the ozone machine manufacturer and the concurrence of LS&Co.

**IA** In case any safety button is pushed, the generator shall be stopped, and the destruction process shall start up at each washer.

**CI** Employees shall be trained annually on the hazards of ozone gas and on the need to stay out of (or evacuate) the ozone installation area if the alarm has been triggered.

**CI** Factory shall have written standard operating and maintenance procedures for safely operating the ozone installation in the local language.

**CI** Machine shall be labelled in a language understood by operators and maintenance personnel.

**CI** All ozone-related documentation should be available to Assessors for review.

## Implementation of Requirements

### *Training, Rules and Record Keeping*

- The factory shall train operators and maintenance staff annually regarding the hazards of ozone gas and regarding the equipment use and safety controls in place.
- Factory shall keep written records to show ozone safety training has been completed.

### *Hazard Controls*

- The factory shall periodically calibrate and maintain the ozone-monitoring equipment to make sure that it works properly and provides accurate information about ozone levels. The factory shall follow the ozone sensor manufacturer's written instructions.
- The factory shall periodically test and maintain the ozone alarms to ensure they are working properly.
- The safety visual and audible alarm signal must be easily distinguished from process alarms.
- The factory shall periodically maintain self-contained breathing apparatus (SCBA). The factory shall follow the SCBA manufacturer's instruction.



**SCBA for emergency or planned entry into unknown concentrations or IDLH (Immediately Dangerous to Life or Health) conditions**



# Health Guidelines



## HEALTH TRAINING

### Purpose

A healthy worker is a productive worker. Poor health is the most common reason workers take a leave of absence from the workplace. Many illnesses are a result of the lack of knowledge among workers about how they can be prevented. Basic health education can help reduce the incidence of these illnesses. The factory can benefit by identifying common health issues that the workers face and by training them on the prevention and control of these problems. At the same time, factory management must remain alert and respond to health issues that emerge in the community.

### Requirements

- CI** The factory should have a system in place for identifying the common illnesses that affect the workers. This system should include an analysis of factory clinic health records and sick leave records, each of which should be maintained in the factory. ([See sample of such records in the Appendices](#)).
- CI** The factory should create a basic demographic profile of the workers by collating and analyzing available information regarding the workforce. This will enhance health training by helping to identify possible health issues that are common in particular groups.
- CI** The factory should have a Health and Safety Committee in place, the membership of which is determined by the workers. This Committee should meet at regular intervals (at least once a month) and discuss the common health issues that are currently affecting the workers and discuss any other factory health issue that committee members identify, or which is brought to their attention. These meetings should be summarized in writing with any other appropriate health information included, with the summaries and other information promptly presented to management. A representative of Management should attend any health and safety meeting to which management is invited.
- CI** Factory management, in consultation with a representative of the Health and Safety Committee, should conduct health needs assessment surveys among the workers at least annually. This will help identify common health concerns. In this regard, see the health assessment paragraph which follows the chart in the [Implementation section](#) below.

**CI** An examination of all information gleaned from the foregoing will be helpful to factory management, in consultation with the Health and Safety Committee, establishing a robust health training program which identifies and effectively responds to whatever health issues may be present in the factory. Health training can be held at intervals that are convenient to the factory but should take place no less than once every four to six months.

Each training should include a new topic, with topics periodically repeated to ensure new workers obtain this information. Each health training session should be summarized in writing. The summaries should be placed in a notebook, and each new employee should be instructed to read this notebook before his or her first Health Training session and periodically thereafter.

**Implementation of Requirements**

- The health care professional (factory medical officer or nurse) should maintain a record of all workers who report to the factory first aid station/ambulance room/clinic. These records should include all visits, no matter how minor the illness may appear. (See sample in the Appendices.)
- The factory human resources team should collate the causes for sick leave as recorded by the health care professional who provides the certification. The common causes for sick leave should be listed in descending order of frequency. This is one way of prioritizing worker health training elements.
- The demographic profile referenced above will be shaped in part by information regarding worker age, gender, and marital status. This information should be analyzed so as to better make informed decisions regarding health issues that workers are likely to be facing (e.g., creating a health training breakout session for young women regarding reproductive health issues).

The following is a sample of topics that are relevant to selected population groups:

Health Topics	Unmarried Women	Married Women	Men
Personal Hygiene	✓	✓	✓
Environmental Hygiene	✓	✓	✓
Ergonomics	✓	✓	✓
Nutrition	✓	✓	✓
Reproductive Health	✓	✓	
Maternal Health	✓	✓	
Child Rearing Practices		✓	
Communicable Diseases	✓	✓	✓

Health Topics	Unmarried Women	Married Women	Men
Diabetes/Hypertension	✓	✓	✓
Cancers	✓	✓	✓
Domestic Violence	✓	✓	
Stress Management	✓	✓	✓
HIV and STDs	✓	✓	✓

- Health needs assessments should be conducted at intervals of a maximum of one year. It is suggested that at least 5% of the total workforce is *randomly selected* for this process. This proportion can be reduced in the case of large factories (more than 1000 workers). Tools for this process are freely available online – <https://herproject.org/resources/curriculum/herhealth>. Factory management, in consultation with the Health and Safety Committee, should make every effort to ensure that the assessment is an accurate representation of health issues within the workforce.
- For most common health problems that are present among the working populations, there are ready-made information sheets, lessons, and modules that are easily available online. The healthcare professional employed by or contracted by the factory can easily adapt the available information and convert it to material that can be used for training the workers.
- It must be understood that it will be difficult for one healthcare professional to personally train all the workers in the factory. The “peer educator” model has been tried and tested in many countries and has been found to be very useful. The health care professional can train peer educators and provide them with materials that can be used for communicating with their peers. It is suggested that at least 5% of the total workforce be trained as peer educators. The health care professional should be available to answer questions that the workers may have.
- Health training sessions may be reinforced by placing posters or distributing pamphlets related to the issue discussed.
- There are a number of resources available for health topics. Some of these include
  - <https://herproject.org/herhealth>
  - <http://hesperian.org/books-and-resources/>
- Factory management should ensure that all health training sessions occur during factory working hours. Production schedules should be adjusted accordingly and should also include time for the health care provider to train peer educators training and for peer educators to meet with workers.
- The health care professional who trains the peer educators should maintain regular contact with them to review the trainings that have taken place with the goal of making future training sessions even better.

- To improve the quality of the training, and to encourage the peer educators, a variety of non-financial incentives may be tried.
  - Peer educators can be recognized by providing them with a special apron or cap
  - They can be given diaries that contain useful health messages and pages to note common questions that are being asked by other peer trainers.
  - The notice boards within the factory should have a list of trained peer educators with their photographs. This not only will be gratifying to the peer trainer but also will better ensure that workers know who they can contact regarding whatever health issues may arise. Peer educators should be instructed that they are not permitted to render medical advice and that only trained medical personnel may provide such advice.
- Factories should be prepared to improvise as appropriate.
  - The health care professional should be permitted to suggest the topics for peer education, after reviewing information from the health needs assessment.
  - While it is quite common to use flipcharts for communication, peer educators should feel free to communicate by whatever means they determine, in consultation with the health care professional, is most likely to be effective for the intended audience.
  - While participatory methods can be used, a lecture-discussion format may be more productive.

### Suggested Timeline

- Month 1:** Health Needs Assessment, including identification of six topics for next 12 months
- Month 2-3:** Preparation of Training Material for 1<sup>st</sup> topic; re-evaluate candidate topic list
- Month 4-5:** Execute Peer Educator Training on 1<sup>st</sup> topic followed by peer-to-peer training  
Simultaneously preparation of Training Material for 2<sup>nd</sup> topic; re-evaluate candidate topic list
- Month 6-7:** Execute Peer Educator Training on 2<sup>nd</sup> topic followed by peer-to-peer training  
Simultaneously preparation of Training Material for 3<sup>rd</sup> topic; re-evaluate candidate topic list
- Month 8-9:** Execute Peer Educator Training on 3<sup>rd</sup> topic followed by peer-to-peer training  
Simultaneously preparation of Training Material for 4<sup>th</sup> topic; re-evaluate candidate topic list
- Month 10-11:** Execute Peer Educator Training on 4<sup>th</sup> topic followed by peer-to-peer training  
Simultaneously preparation of Training Material for 5<sup>th</sup> topic; re-evaluate candidate topic list

**Month 12-13:** Execute Peer Educator Training on 5<sup>th</sup> topic followed by peer-to-peer training  
Simultaneously preparation of Training Material for 6<sup>th</sup> topic; identify topics for next 12 months

**Month 14-15:** Execute Peer Educator Training on 6<sup>th</sup> topic followed by peer-to-peer training

**Month 16-18:** Review and re-plan next round

---

## WATER, SANITATION, HYGIENE (WASH)

### Purpose

**We must recognize that a number of illnesses are caused by unsatisfactory quality and quantity of drinking water, poor sanitation and a lack of hygiene – either individually or more often, when in combination. Very often, the diseases caused by poor water, sanitation and hygiene occur in isolation, where an individual employee will be affected; but of greater concern is**

**the situation when a group of employees from the factory suffer from illnesses at the same time. The latter is often indicative of poor working conditions in the factory. The prevention of diseases related to water, sanitation and hygiene is possible with the institution of simple control measures at the factory level.**

### Requirements

- IA** The creche will comply with all applicable local legal requirements.
- CI** The factory management and other concerned staff (environment, health and safety team members) should ensure that the local rules and regulations pertaining to WaSH are followed diligently – this in itself will ensure that most diseases resulting from poor WaSH conditions are prevented, or at least controlled.
- CI** With reference to water, specifically drinking water, the management should ensure that adequate quantities and safe, quality drinkable water – physical, chemical and microbiological – is provided to the employees at all times.
- CI** The factory management should ensure that other facilities related to sanitation and hygiene are also provided – these include adequate numbers of restrooms (toilets), washrooms, hygienic food services (canteens) and proper disposal of wastes (solids, effluents and sewage).
- CI** The management should also provide adequate facilities for the employees to follow good practices of personal hygiene. These include facilities for the safe disposal of products for feminine personal hygiene, handwashing and storage/washing of clothes that are soiled at work.

### Implementation of Requirements

- The factory management and EHS team should be aware of all the local laws pertaining to WaSH. The best practices for each of the issues – water, sanitation and hygiene – should be identified and followed. If necessary, the assistance of local experts should be sought and solutions for difficult conditions be identified.

- The presence of and empowerment of a Health and Safety Committee and/or EHS Team will help in the identification of illnesses or diseases related to poor WaSH as soon as the first cases start occurring.
- Local laws for the quantity of drinking water to be provided are usually in place – these are to be followed diligently, knowing that reduced quantities of water can itself lead to consumption of poor quality of water from other sources, leading to gastro-intestinal infections.
- Adequate samples of drinking water, collected from the point of consumption, should be sent for laboratory tests at regular intervals. In addition, any suspicion of outbreaks of gastro-intestinal diseases should also provoke immediate checks on the quality of water.
- Again, in keeping with local regulations, the required number of toilets, washrooms and other facilities should be provided and more importantly, maintained well. In facilities where employees are exposed to chemicals at work, facilities should be provided for their bath and change of clothes before they go home.
- Other facilities that are likely to face challenges with hygiene, such as the kitchen services, any snack store within the premises, or the dining area, should be regularly inspected, and incident problems should be corrected.
- Environmental hygiene should not be neglected – regular checks of waste disposal, drainage, sewage and effluent treatment systems should be instituted.
- Regular health education sessions for the employees, in addition to adequate instructions during induction training programs, will ensure that the employees also understand their role in the maintenance of good WaSH conditions within the factory (if not at home as well).

## CANTEEN

### Purpose

**Given the fact that many employees leave for work early from home, thus making it difficult to prepare a good mid-day meal, it is good practice for factories to provide the option of a healthy and wholesome meal for their employees. Additionally, the provision of a freshly cooked meal, served under hygienic conditions, benefits the employee and the management by reducing the possibility of illnesses due to poorly preserved home-cooked food.**

### Requirements

- CI** If the management provides a catering facility within the factory premises, it should ensure that the general recommendations for quality food service establishments are followed here as well.
- CI** Management should ensure that all raw materials are freshly procured and stored under hygienic conditions before being used as ingredients for the preparation of meals.
- CI** Management should ensure that all hygienic measures are undertaken in the preparation of the meals, which includes the maintenance of the kitchen and the dining area in proper condition. Importantly, all food-handling personnel should be medically fit to carry out their responsibilities.
- CI** While ensuring minimal wastage of cooked food, all food leftovers should be disposed of in a hygienic manner
- CI** All employees working in the kitchen (food handlers) should be medically examined at least once in 6 months to ensure that they are healthy. A certificate as proof of this should be obtained from the examining physician.

### Implementation of Requirements

#### *Kitchen/Serving/Dining Premises*

- Ensure that there are no fly breeding areas within 50 feet of the kitchen, dining area or facility where food is prepared or served. Ensure that adequate fly trapping equipment are placed in the dining area.
- Ideally the canteen, kitchen, dining area should be a separate building. However, in situations where this is not possible, it should be located on a separate floor not contiguous with the work area of the factory.

- The floor of the entire premises should be smooth and impervious. The walls and roof also should be of a quality that will not allow for the lodgment and growth of disease causing/spreading entities like flies or vermin.
- The kitchen should preferably be a separate facility/room – not contiguous with the serving area or dining area. The fuel used should be non-biomass thus ensuring that excessive smoke is not released as part of the cooking process. Smoke outlets – simple chimneys, or, if required, smoke extractors, should be installed to ensure a healthy environment for those working in the kitchen. Adequate cross-ventilation should be provided in all areas of the food preparation/service/dining facilities.
- The recommended area per person using the dining room facility is 10 sq feet.
- The water used for cooking should be of good quality – physical, chemical and microbiological. The water should be tested at regular intervals to ensure that it is potable (fit for human consumption). Adequate arrangements should be made for storage or drinking water – clean water, should be stored in clean containers – and this water should also be tested for quality at regular intervals.
- The store for raw materials should also be a separate room with the facility to store perishable and non-perishable raw food separately. All food articles should be stored at least 3 feet above ground level.
- All cooked food should be stored in fly-proof containers.
- All food preparation surfaces and cooking table-tops should be made of impervious, non-absorbable materials.
- All utensils used for preparation and cooking food should be of a quality that does not cause other health problems – some societies use iron plated or lead/tin coated vessels, which should be avoided.
- Good quality facilities should be provided for handwashing. This should be separate from the waste food disposal area – to ensure that food wastes do not clog the pipelines. Employees should be advised and monitored on a regular basis to ensure that hygienic practices of handwashing, plate disposal and waste disposal are carried out. All sullage should be disposed of appropriately.
- Provisions should be made for large enough containers for the disposal of food wastes. All food waste should be removed regularly and disposed of appropriately.
- All utensils/vessels used for preparation, serving and consuming food should be washed with good quality detergents and dried before use for the next meal.
- Appropriate measures should be taken for general housekeeping – ensuring that the entire area is clean. Clearly documentation of the cleaning procedures and their frequency is important.
- The recommendations of the WHO Day Theme for the Year 2015 are very relevant to the food service facility. These are:
  - Keep clean
  - Separate raw and cooked food
  - Cook food thoroughly
  - Keep food at safe temperatures
  - Use safe water and raw materials

More details are available at: <http://www.who.int/campaigns/world-health-day/2015/event/en/>

### Health of Food Handlers

- All food handlers should have a medical exam once every six months to ensure that they are healthy and do not have any diseases that are likely to spread to the consumers.
- Particular attention should be paid to diarrheal diseases and typhoid – which are common illnesses that are transmitted by food handlers. Food handlers should be tested to check if they are carriers of typhoid – adequate treatment should be given if they are tested positive (by stool examination). They should also be given deworming medication once every six months.
- The supervisor should examine all food service employees for their hygienic practices – adequate hair cropping and protection, cut nails, presence of any skin infections, etc.
- Food handlers should be trained and monitored for practices of good hygiene. While it is imperative that these practices are part of the routine in the establishment, particular attention to these details is important during epidemics of influenza or other communicable diseases.
- Food handlers should be provided vaccination against typhoid

## FIRST AID

### Purpose

**First aid is the care given to an injured worker before professional medical help arrives. First aid may mean the difference between life and death. The purpose of this section is to preserve life, prevent any injuries from getting worse, and help injured workers recover.**

### Requirements

- CI** Factory shall identify the common hazards that are present in the factory, as indicated in this manual. This step will have to be repeated at regular intervals, especially when new machinery is installed and when the factory layout has been altered.
- CI** Factories should maintain up-to-date written records of injuries, no matter how minor they appear to be. Every time the First Aid Box is opened, the reason has to be documented. These records should include a description of the circumstances, the time and date of the injury, a description of the injury, and the first aid provided. In addition, injury records should identify the worker and the department to which s/he belongs. While all injuries should be logged in a register, more serious injuries should be described in detail. ([See Appendices for suggested formats](#)).
- CI** Factories should provide at least one First Aid Box per 100 workers. The kits should be located on the factory floor to give workers immediate access. There should be a signboard that clearly displays their location. At induction (training) and at least every six months thereafter, each worker should be told of this location. The first aid kits should not be kept under lock and key.
- IA** First aid kits are recommended to be fully stocked with the items listed in the table below:

First Aid Supplies		
Supply	Size/Type	Quantity
Absorbent Compress	84 sq.cm (32 sq.in) with no side smaller than 10 cm (4 in)	1
Adhesive Bandages	2.5 x 7.5 cm (1 x 3 in)	16
Adhesive Tape	460 cm (5 yards)	1
Antiseptic liquid	100 ml	1 bottle
Antiseptic cream	20 gm	1 tube
Sterile pads	7.5 x 7.5 cm (3 x 3 in)	4
Triangular Bandage	100 x 100 x 140 cm (40 x 40 x 56 in)	1

First Aid Supplies		
Supply	Size/Type	Quantity
Cold pack		1
Surgical gloves		1 pair
Hand sanitizer		1

**Note:** This kit does not contain any tablets like aspirin or paracetamol – these should be made available only with a trained nurse at a first-aid station or ambulance room. Similarly, local pain-relieving ointments are also not listed above and should be made available at the discretion of the factory management.

All aseptic precautions must be taken in the storage of the items listed in the kit.

- IA** The number of workers who should be trained to give first aid depends upon the overall worker strength and the distance of the factory from the nearest medical facility.
  - For all factories with fewer than 500 workers, at least 1% of the workforce should be trained in first aid and 2 workers per shift should be trained in Cardio-Pulmonary Resuscitation (CPR) techniques.
  - Factories with more than 500 workers, and all factories where medical facilities are more than 5 minutes away, should have a full-time medical professional onsite during all hours that the workers are in the factory.
- CI** Factories should have written procedures to treat workers needing first aid. (See sample of procedures for common injuries in the Appendices)

## Implementation of Requirements

### **Training, Rules and Record Keeping**

- Workers who have been selected and agree to be first aid responders should be trained and certified by a qualified contractor. (See [sample of training program](#) in the Appendices). First aid responders should go through a refresher periodically, ensuring also that those who have left employment are replaced with new volunteers.
- First aid training should be documented, with certificates given to the workers who successfully complete the first aid course and copies maintained in the factory files.
- Factories should keep a written record of first aid incidents that includes the name of the injured worker and other identifiers along with the circumstances that led to the injury. A short description of the first aid given should also be included. (See sample of a first aid register and a sample of the injury record in the [Appendices](#).)

- Each first aid kit should have a label listing the contents and noting the date on which it was last refilled. Emergency telephone numbers should be listed on the first aid kit and near all telephones.
- Factories should ensure that all medications are at least 6 months short of their printed expiration date.

### **Hazard Assessment**

- Factories should create a factory first aid program that identifies the first aid responders and the locations of first aid kits. The program will also include written first-aid instructions for the common injuries seen in the factory.
- Factories should annually review the first aid program to make sure the first aid requirements are met. This review should also take into account improvements that have been made to the existing program. This review should be recorded in writing.
- Hazard Controls
- First aid responders should be offered a consultation with a medical professional and the Hepatitis B vaccination (if required) within 10 days of completing their first aid training. The course of Hepatitis B vaccination should be completed as indicated by the medical professional. (Usually three doses, one on Day 1, the second after one month and the third after 6 months).
- Vaccination services should be provided at no cost to the worker, at a convenient place and time, and supervised and endorsed by a licensed physician or other licensed healthcare professional.
- Factories should establish a system to inspect first aid kits on a regular basis to make sure they have all the supplies listed in the requirements section.

---

## COMMON DISEASES

### Purpose

**A healthy worker is a productive worker, and poor health is the most common reason workers take leave of absence from the workplace. There are many diseases that can cause distress in the factory. Some of these can be transmitted from one person to another (hence called communicable diseases) and others cannot be transmitted (hence called non-communicable diseases). More importantly, in the case of communicable diseases, employees can bring these diseases into the factory and transmit them to other employees. Also important is the fact that environmental conditions in the factory can be favorable to the transmission of some communicable diseases from one employee to another. Non-communicable diseases, on the other hand, are diseases of lifestyle and in this case, factories can help prevent them by encouraging behavioral changes.**

### Requirements

- CI** Factory management and health care providers should be constantly attentive to the health issues that affect the communities around them and realize that if they are not vigilant these illnesses can affect their own employees.
- CI** Factory management and health care providers should also be aware of the diseases from which employees are currently suffering. The systems referred to in the chapter on “Health Training” will help in identifying common illnesses among the employees.
- CI** A Health and Safety Committee as described in the Health Training requirements should be established. This will help identify the presence of communicable diseases among factory employees.
- CI** A demographic profile of the employees as described in the Health Training requirements should be created and scrutinized so that, along with appropriate interventions, non-communicable diseases can better be identified and controlled at an early juncture.

### Implementation of Requirements

- The healthcare professional (factory medical officer or nurse) should be aware of the common communicable diseases that are prevalent in the community around the factory. More importantly, the health care professional should be proficient in the prevention and control of these diseases as well as in the appropriate treatment that should be provided should an employee demonstrate symptoms and signs of the disease.

- The healthcare professional and the safety officer (if available) should constantly look out for environmental factors within the factory premises that are likely to promote the spread of communicable diseases.
- The healthcare professional should be knowledgeable about the modes of transmission of the common diseases ([see Appendices](#)) and take adequate precautions, including appropriate communication with management, to ensure that these are addressed appropriately.
- In the case of non-communicable diseases, the health care professional should be aware that these are diseases that commonly affect older age groups and also those with poor lifestyles. Health promotion through education and other interventions should be implemented to help prevent the onset of these diseases. Regular health checks to monitor the health status of the workers, especially those who are at risk, should be initiated to help identify disease onset. Appropriate steps should be implemented to prevent the disease from progressing.
- A short description of the common illnesses – both communicable and non-communicable – is given in the appendices. Factory management should peruse these appendices, especially the sections that describe the prevention of each illness, so that in consultation with health care professionals, appropriate actions can be undertaken to address these illnesses.
- Factory management must store all details related to health data confidentially, and it should never be disclosed to a person other than the one it is intended for.

### Key Definitions:

**Disease:** The term disease broadly refers to any condition that impairs the normal functioning of the body. For this reason, diseases are associated with the dysfunction of the body’s normal homeostatic process.

**Contagious disease:** An infectious disease communicable by contact with the one who has it, with bodily discharge or with an object the patient has used.



---

## PREVENTING COMMUNICABLE DISEASE

### Purpose

A communicable disease is one that may be spread from one person to another by direct contact with blood or other body fluids. It may also be spread by direct contact with diseased animals, or by taking in contaminated food, water, or air. Human Immunodeficiency Virus (HIV) and Hepatitis B Virus (HBV) are examples of communicable diseases. The purpose of this section is to explain the requirements for preventing the spread of communicable diseases among factory workers.

### Requirements

- IA** The factory must provide toilets that are clean and in good working condition for workers' use.
- IA** The factory must have plenty of safe drinking water; it must be available, at no cost, to all workers at all times.
- IA** The factory must have an Exposure Control Plan to prevent workers from contacting blood or other body fluids that may contain harmful organisms, such as HIV or HBV.
- CI** Kitchens should be clean and organized for safe food preparation.
- CI** The dining halls or other eating areas should be kept clean and separate from the main work area.
- CI** The factory should keep a written record of any injuries caused by needle sticks or cuts.

### Implementation of Requirements

#### *Training, Rules and Record Keeping*

- Workers should be trained on the Exposure Control Plan.
- "Sharps containers," also known as "safety boxes," are made of material that is inflexible, leak-proof, and resistant to being punctured by the sharp objects it contains. Sharps containers should be supplied for workers to dispose of broken needles, scissors, or cutting blades.
- The following list of supplies should be kept on-site and easily available to workers to prevent accidental exposure to blood or other body fluids:
  - Protective gloves
  - Handling devices (tongs, tweezers, forceps, magnets)

- CPR mask with one-way valve mouthpiece (to prevent first-aid responders from contacting a victim's body fluids)
- Disinfectant (such as 10% bleach solution)
- Sharps containers

### *Hazard Assessment*

- Factories should regularly test drinking water for bacteria and lead and should act to improve the drinking water if the tests show it to be unhealthy. Factories should keep written records of these tests.
- Factories should identify workers whose tasks may expose them to blood or body fluids (e.g., first-aid responders, sewing machine operators, kitchen workers). These workers should be offered the Hepatitis B vaccine and a meeting with a medical professional within 10 days of beginning their work.
- When a new task is introduced into the work area, factory managers should decide whether it may expose workers to blood or body fluids. If so, managers should make sure that workers are trained on the Exposure Control Plan and that the Plan is being followed in that work area.

### *Hazard Controls – Exposure Control Plan*

- The Exposure Control Plan should address the following requirements:

#### *Sharp Objects*

- Include clear rules and procedures for safely handling broken needles, cutting blades, glass, security tags, or other sharp objects. These rules should apply to sharp objects that may be contaminated (that is, they may have contacted blood or other body fluids) as well as to those sharps that are not contaminated.
- An example of such a rule might be: "Do not handle broken sharp objects or broken glass by hand. Use tongs, forceps, tweezers, magnets or other devices to pick up and discard the broken object."
- Workers should dispose of sharp objects in sharps containers which have been labeled as "Biohazard" and "Sharps Waste" in the local language.
- Factories should keep written records of injuries caused by sharp objects and of incidents requiring first aid.

#### *Cleaning and Disinfecting*

- Include specific procedures for cleaning and disinfecting contaminated work areas and equipment.
- "Disinfect" means to use heat or chemicals to destroy harmful organisms. This is typically done with a 10% bleach/ water solution.

- When cleaning and disinfecting contaminated areas or equipment, workers should wear protective gloves (such as latex or other watertight gloves). Other personal protective equipment may be required, depending upon the task. For example, if cleaning and disinfecting may cause splashing, workers should wear safety glasses or goggles. Workers are required to wash their hands after they remove their gloves. If there is not a sink nearby, cleansing wipes should be provided instead.
- If work surfaces (including kitchen counters) or equipment have come in contact with blood or other body fluids (for example, a worker's finger has been punctured by a sewing machine needle and has bled onto the equipment surface), these surfaces should be cleaned and disinfected immediately. Workers should spray contaminated equipment or surfaces with a 10% bleach/water solution and wait at least 5 minutes before wiping these surfaces. (Note: In addition to the bleach solution, other disinfecting materials may be approved by factory managers.)

### ***Kitchen***

- Workers who prepare and serve foods should keep their skin and hair clean and wear clean clothing.
- Raw poultry, fish, and meat should be prepared separately from vegetables, fruits, and cooked foods.
- Uncooked foods (with the exception of dry goods such as grains) should be kept refrigerated.
- Dishes and utensils should be cleaned (by washing in hot water and detergent and then rinsing in hot water) between uses. Kitchen work surfaces and equipment should routinely be cleaned and disinfected using the procedure described in the "Cleaning and Disinfecting" section.

### ***Toilets***

- Toilet facilities should be provided with running water and stocked with toilet paper (where culturally appropriate) and anti-bacterial soap or instant hand sanitizer at all times.
- Factories should be equipped with enough toilet facilities to serve the worker population. For example, if a factory employs many more female workers than males, it should provide more female toilet facilities than male toilet facilities.

### ***Dining***

- Dining areas should be clean, protected from the weather, and have enough seating for all the workers who may be on break at any one time.

## **PANDEMIC MANAGEMENT**

### **Purpose**

**Good pandemic management can result in better business continuity and legal compliance. By consulting the most up-to-date LS&Co. pandemic guidance(s) on a regular basis, a factory can identify areas for continuous improvement to keep the workplace safe and employees healthy.**

### **Requirements**

- IA** At a minimum, all new and existing suppliers' facilities producing for LS&Co. must meet all applicable local legal pandemic (e.g. bird flu, swine flu, COVID-19, etc.) requirements.
- IA** Factories should ensure that all facilities producing for LS&Co. comply in all respects with the specific LS&Co. pandemic guidelines relevant to an outbreak (e.g. bird flu, swine flu, COVID-19, etc.).

### **Recommendations**

Factory should frequently check the updated LS&Co. [pandemic guidelines](#).

# Environmental Guidelines



## ENERGY MANAGEMENT

### Purpose

**Good energy management can result in energy-related cost savings and a more reliable energy supply. By tracking and monitoring energy usage on a regular basis, a factory can identify areas for improvement and set targets for reducing energy consumption.**

### Requirements

- CI** Factory should track its energy consumption information according to the questions in Level 1 of the Higg Index Facility Environment Module, which includes:
  - Quantity of energy consumed, per energy type (for example: electricity, natural gas, diesel fuel, solar, wind)
  - Unit of measurement
  - Method of measurement
  - Frequency of measurement
  - Start date and end date of energy measurement
  
- CI** Factory should maintain records of monthly energy usage for up to two years that may be made available upon request by an external auditor.

### Recommendations

- Factory explores options for renewable energy such as on-site solar or wind energy.

---

## WATER MANAGEMENT

### Purpose

**Good water management can result in reduced regulatory, reputational, and scarcity risks for factories.**

### Requirements

- IA** Factory must have a water meter to measure its regular water consumption. If a factory does not currently have a water meter, it should have one installed with outside expert guidance (see guidelines below).
- CI** Factory should track its water consumption information according to the questions in Level 1 of the Higg Index Facility Environment Module, which includes:
  - How much water is consumed annually
  - Water sources (for example: municipal source, groundwater well, lake, river, etc.)
  - Unit of measurement
  - Method of measurement
- CI** Factory should maintain records of monthly water usage for up to two years that may be made available upon request by an external auditor.

### Recommendations

- Factory explores options for water efficiency or water recycling in accordance with the LS&Co Recycle/Reuse program: <http://www.levistrauss.com/wp-content/uploads/2014/02/LSCo-Water-Recycle-Reuse-Standard.pdf>

### Water Meter Guidance:

1. **Meter location.** Meter should be placed on the intake pipe entering the factory. Ideally, a second meter would be placed on the effluent (wastewater) pipe.
2. **Types of water meters.** For technical background on different water meter technologies, please refer to this guideline produced by Partnership for Cleaner Textile (PaCT): <http://www.textilepact.net/pdf/water-metering-and-monitoring-in-cleaner-production-management-system.pdf>
1. **Installation guidelines.** Although LS&Co is unable to provide technical installation assistance to vendors, please use the above document produced by Partnership for Cleaner Textile (PaCT) for basic guidance. Factory may need to consult with an outside expert for installing water meters.

---

## ZDHC WASTEWATER REQUIREMENTS (FORMERLY 'GLOBAL EFFLUENT REQUIREMENTS')

- IA+** At a minimum, all existing and new suppliers must ensure that all effluents from all factories producing for LS&Co. meet all applicable legal discharge requirements and comply in all respects with the ZDHC Wastewater Guidelines and the limits set forth in Table 2 ZHDC Heavy Metals and Table 3 ZDHC Conventional and Anions.
- IA+** Direct Discharge of Industrial Wastewater without proper treatment methods that may cause serious impact on the natural environment is strictly prohibited.
- CI** Factories should ensure that all effluents from all factories producing for LS&Co. comply in all respects with the ZDHC Wastewater Guidelines and the limits set forth in the table 1 "ZDHC MRSL" and Table 4 "ZDHC Sludge"

## BIO-SOLIDS MANAGEMENT

### Purpose

Bio-solids are sewage sludge that has been treated to remove pollutants and disease-causing organisms; this material can be recycled, typically as a soil amendment, because of the plant nutrients it contains. The purpose of this section is to explain the requirements for managing the resulting bio-solids, in order to control environmental and health hazards.

### Requirements

- CI** Bio-solids should be reused or disposed of at a facility with valid permits, which should be checked by factory personnel.

### Implementation of Requirements

#### *Training, Rules and Record Keeping*

- Factories should keep written records about the disposal methods they use for bio-solids, including verification that receiving facilities have permits to use or dispose of bio-solids.

#### *Hazard Assessment*

- If factories treat domestic sewage on site, the resulting sewage sludge should be thickened, stabilized, conditioned, disinfected, dewatered, and made into bio-solids prior to transportation.
- Bio-solids should only be transported in a water-tight truck that has the proper permits.



**Good practice:** Bio-solids ready for transportation after proper bio- solids management processing (i.e., thickened, stabilized, conditioned, disinfected, and dewatered).



**IA** **Bad Practice:** This truck is not watertight and lacks the proper signage. It is unacceptable for bio-solid transport. Plastic lining is required to make watertight.

- Bio-solids should be reused, recycled, or disposed of. Solutions for disposal of biosolids include:

- Mono-fill (a landfill that accepts only wastewater treatment plant biosolids)
- Designated disposal landfill
- Land-filling with biogas recovery
- Incineration
- Agricultural purposes (e.g., fertilizer)
- Silviculture
- Composting
- Cotton crust
- Bricks
  
- Ceramics
- Other acceptable recycling programs



**Example of a mono-fill: a sludge pit that is properly lined.**

- If a factory is unable to achieve any of the above solutions, it should discuss its situation with the LS&Co. contact.

## PREVENTING STORM WATER POLLUTION

### Purpose

Factory activities such as chemical storage, equipment handling, etc., can mix pollutants into rainstorm water that flows off the property and into bodies of water such as streams, rivers, ponds, oceans. This can harm the environment and create community health hazards. The purpose of this section is to describe the requirements for practices that can be used to minimize the amount of pollutants in storm water that flows off factory property.

### Requirements

**CI** Factories should regularly inspect the exterior of buildings and surrounding parking areas, grounds, equipment, etc. to ensure that best management practices are used at the factory and are effective in controlling storm water pollution. Written records of these inspections should be kept by the factories.

**CI** Workers whose activities may cause pollutants to be mixed into storm water should be trained on the subject of storm water pollution; this training should emphasize the importance of using the best management practices.



or discharge helps prevent

stream bank erosion.

### Implementation of Requirements

#### Training, Rules and Record Keeping

- Factories should keep written records of the specific training provided to workers whose activities may cause pollutants to be mixed into storm water.
- Factories should have written records that include the inventory of potentially polluting materials (see "[Hazard Assessment](#)" section, below) and the periodic inspections.

#### Hazard Assessment

- Factories should create a list of the materials (other than clean water) that have the potential to come into contact with storm water and pollute it. These may include raw materials, fuels, solvents, detergents, finished products, fertilizers, pesticides, herbicides, and waste materials. Materials should be included in this list if they are used, stored, or transported in areas where they could contact rain as it falls or storm water on the ground.

- Factories should regularly inspect equipment, grounds and areas outside the factory to identify any conditions or practices that might pollute storm water and to assess if best management practices are effective in preventing pollution. Written records should be kept of these inspections.

#### Hazard Controls

- Stormwater pollution is best prevented by using a standard set of practices called "best management practices." These practices are listed below and have been included in the Appendix.

### Best Management Practices

- Chemical / Raw Material Storage (in sheltered area, away from storm water drains—see the Chemical Management section)
- Housekeeping (regular removal of trash, orderly material storage to avoid spills, etc.)
- Preventive Maintenance (check equipment for spills and leaks, regularly clean out containment areas, etc.)
- Spill Prevention and Response (check material storage, wastewater piping, etc. for damage or leaks; keep an inventory of spill clean-up materials ready, etc.)
- Periodic Inspections (ongoing daily inspections of potential storm water contact areas, monthly inspections of areas, equipment, best management practices)
- Employee Education and Training
- Sediment and Erosion Control (paving, maintaining vegetation in unpaved areas, etc.)
- Structural Improvements (installing roofs over exterior storage areas, installing containment areas, etc.)
- Documentation and Record Keeping (training, inspection, inventories)



Good practice: Empty barrels stored in sheltered area reduces

risk of stormwater pollution.

---

## ABOVEGROUND/UNDERGROUND STORAGE

### Purpose

**Storage of petroleum products and hazardous materials in underground or aboveground tanks presents a risk of spilling or leaking the hazardous materials into the environment. The purpose of this section is to describe the best management practices for storage tanks in order to minimize this risk.**

### Requirements

- CI** Factories that operate aboveground or underground storage tank systems that contain petroleum products or hazardous materials should have a written plan for preventing spills or leaks to the environment. This plan should be kept on site and should be updated or improved whenever there is a change in factory operations or if there has been a spill or leak of material into the environment. The plan should include at least the following:
  - a current list of all aboveground and underground tanks that contain petroleum products and hazardous materials;
  - procedures to prevent spills or leaks, including while doing routine tasks, such as transferring small amounts of material to smaller containers;
  - procedures for monitoring aboveground or underground storage tank systems for leaks;
  - testing of secondary containment systems for aboveground or underground storage tank systems, if present;
  - an emergency response plan for an incident involving a spill or leak from a storage tank;
  - inspection forms; and
  - requirements for training workers.
- CI** Factory workers who have responsibility for the operation and/or maintenance of tank systems should be trained on best management practices for storage tanks. This training should be provided within 30 days of hire, and again each year after. A written record should be kept showing this training was completed.
- CI** Routine inspections should be conducted on storage tank systems, including site-owned, oil-filled power transformers.
- CI** A report form should be completed if a spill or leak occurs. This allows the factory to keep a written record of spills/ leaks and of the corrective actions taken to prevent future spills or leaks.

---

## Implementation of Requirements

### *Hazard Assessment*

- Factories should routinely inspect storage tank systems (tanks, containment, pipes, connections, etc.) to make sure they are intact and in good condition. A written record should be kept of these inspections. Completed inspection forms should be kept on file as part of the factory's operating records.

### *Hazard Controls*

- Secondary containment should be provided for large storage containers and aboveground storage tank systems. The containment system should hold 110% of the contents of the largest tank.
- Underground storage tanks should be equipped with a leak- detection monitoring system. If feasible, underground storage tanks should also be equipped with a secondary containment system.

## WASTE MANAGEMENT

### Purpose

The purpose of this chapter is to describe the requirements for making sure that wastes are safely transported, handled and disposed of.

### Transporting Hazardous Materials

If they are not packaged and transported safely, hazardous materials may leak or spill and cause harm to factories, factory workers, transportation workers, communities in which we do business, and the environment. The purpose of this section is to describe the requirements for making sure that hazardous materials are transported safely to and from the factory.

### Requirements for Transporting Hazardous Materials

- IA** Factories must prepare and follow written procedures to safely receive hazardous materials into the factory (e.g., from a chemical supplier) and ship hazardous materials/ wastes away from the factory.
- IA** Workers who ship or receive hazardous materials or hazardous wastes must be trained about the hazards associated with these materials and be familiar with the factory's procedures.
- IA** Factories shall only use permitted transporters that have a record of operating safely and complying with transportation laws and best management practices.
- IA** Factories shall provide information to transporters about the physical, chemical, and environmental hazards of hazardous materials and hazardous wastes they ship off-site.
- IA** Factories that transport hazardous materials/wastes using owned or leased vehicles (e.g., to another facility for storage or to a treatment facility) must also have specific procedures to safely transport hazardous materials. These procedures must comply with federal, state, provincial, and/or local laws and regulations governing transporters, and with best management practices.
- IA** Factories must keep written records of employee training and must keep copies of transporter permits and licenses and hazardous material/waste shipping documents

## Implementation of Requirements

### Training, Rules and Record Keeping

- Factories should be familiar with the laws governing the shipment of hazardous materials off site.
- Factories should train all workers who ship and/or receive hazardous materials, initially and on an annual basis. The training should cover the hazards of these materials, as well as the factory's procedures for safely transporting hazardous materials.
- Written training records should be kept and made available to Assessors upon request. These records should show that all employees who are responsible for shipping or receiving hazardous materials:
  - Have been identified and trained
  - Understand the hazards associated with these materials
  - Are knowledgeable about the legal and regulatory requirements that apply to shipping and receiving hazardous materials
  - Understand the company's procedures for safely receiving hazardous materials into the factory and shipping hazardous materials and hazardous wastes away from the factory
- Factories should be familiar with the laws governing the shipment of hazardous materials off-site.
- Factories should train all workers who ship and/or receive hazardous materials, initially and on an annual basis. The training should cover the hazards of these materials, as well as the factory's procedures for safely transporting hazardous materials.
- Written training records should be kept and made available to Assessors upon request. These records should show that all employees who is responsible for shipping or receiving hazardous materials.
  - Have been identified and trained
  - Understand the hazards associated with these materials
  - Are knowledgeable about the legal and regulatory requirements that apply to shipping and receiving hazardous materials
  - Understand the company's procedures for safely receiving hazardous materials into the factory and shipping hazardous materials and hazardous wastes away from the factory



**Good Practice: A hazardous materials transport truck with appropriate placards and signs.**



## Hazard Controls

- Factories should establish and enforce written procedures for loading and unloading hazardous materials, which include, at a minimum:
  - Specific instructions to be given to transporters about routing, parking, and delivery of hazardous materials
  - Practices for safely loading/unloading hazardous materials
  - Sign-off and receipt of hazardous materials/waste shipping documents
- Factories should prepare written procedures for the delivery of bulk materials (such as fuel oil) that include specific measures to prevent over-filling and to respond to an emergency event such as a spill or release.
- Factories should identify and select only qualified, permitted transporters with a record of operating safely and obeying transportation laws and best management practices. Factories should maintain a current copy of the transporter permit(s) on file and make these records available to the Assessors.
- Factories should periodically audit their transporters' safety performance and verify that transporters maintain the required permits and licenses.
- Factories should provide written hazard information for transporters carrying hazardous materials from the factory to allow them to (a) select the correct tank and equipment, (b) post the proper warnings signs on the vehicle, and (c) instruct the driver on necessary safety measures, including actions to take in case of emergency.
- Factories should identify and provide transporters with the telephone number of a specialist who is knowledgeable about hazardous materials transportation emergencies and is available to provide transporters with advice on a 24-hour per day, 7 days a week.

basis. An example of such a specialist is the Chemical Transportation Emergency Center, known as "Chemtrec," which is based in the United States, but provides services in many regions of the world.

## Further Information

- [See the Appendix.](#)
- For information on Chemtrec: <https://www.chemtrec.com/about-chemtrec>
- See the [Hazardous Waste section.](#)

## TRANSPORTING HAZARDOUS MATERIALS

Hazardous wastes that are disposed of improperly can pollute the air, land, groundwater, and waterways, harming the environment and threatening community health. It is important that any amount of hazardous waste be managed properly to avoid contaminating the environment. The purpose of this section is to describe how factories should properly manage hazardous wastes.

### Definition

A "hazardous waste" is a "solid waste" which, because of its quantity, concentration, or physical, chemical, or infectious characteristics, may: (a) pose a significant or potential hazard to human health or the environment when improperly treated, stored or disposed of, or otherwise mismanaged; or (b) cause or contribute to an increase in mortality, or an increase in irreversible or incapacitating illness.

A "solid waste" is defined as any material that is no longer useful or that is discarded by being disposed of, burned or incinerated, recycled or that is considered "waste-like." A "solid waste" can physically be a solid, liquid, semi-solid, or container of gaseous material.

### HAZARDOUS WASTES ARE GENERALLY CATEGORIZED AS FOLLOWS:



**Ignitable hazardous wastes, with a flashpoint of 140° F (60° C).**



**Corrosive hazardous wastes, including strong acids and bases.**



**Reactive hazardous wastes, which include wastes that are normally unstable, react violently with water or generate toxic gases when exposed to water or other materials.**



**Toxic hazardous wastes, which contain certain substances determined to be harmful at or in excess of certain concentrations. Some of those substances include lead, arsenic, and mercury.**

## Common Types of Hazardous Waste

### Examples of hazardous waste include:

- Spent chemicals, such as bleach, solvent-based paint, flammable solvents, and caustic cleaners
- Used oil and un-drained oil filters
- Used batteries
- Used fluorescent / high-intensity-discharge lamps
- Electronic equipment (such as computers)
- Electrical equipment containing polychlorinated biphenyls (PCBs)
- Ballasts (PCB and Non-PCB)
- Pesticides
- Medical Waste (e.g., sharps such as hypodermic needles)

## Requirements for Hazardous Waste Management

**IA+** Factories shall treat, recycle, or dispose of all hazardous wastes they generate by using a permitted hazardous waste contractor or recycler, whenever feasible.

**IA+** Factories may not dispose of hazardous wastes in a nonhazardous waste landfill, solid waste landfill, or local “dump.”

**IA+** Factories shall dispose of dry chemical bags by incineration; these wastes may not be disposed of in a landfill.

**IA** Factories shall identify and track the types and amounts of hazardous wastes they generate as a result of production and business activities.

**IA** Factories shall manage all hazardous wastes in a way that minimizes the possibility of exposing workers and contaminating the environment (air, land or water).

**IA** Factories shall audit hazardous waste recycling, treatment, or disposal facilities to ensure the facilities and the methods they use are appropriate and adequate before sending any wastes to them. Audits must be kept on file for review, upon request, by Assessors.

**IA** Factories may not co-mingle or mix hazardous and nonhazardous wastes (see picture).

**IA** Factories shall dispose of hazardous waste that cannot be treated or recycled at a secure,



**Bad Practice: Co-mingling or mixing of hazardous and non-hazardous wastes**

permitted landfill designated for hazardous waste disposal that has no access to the general public or any unauthorized personnel.

**IA** Factories shall recycle, treat or incinerate liquid hazardous wastes; liquid wastes may not be disposed of in a landfill.

**IA** Factories shall develop and implement a written procedure for managing empty hazardous waste containers to prevent exposing employees to harm and contaminating the environment. Empty containers may not be given to the public or employees for personal use.

**IA** All employees who handle hazardous wastes shall be trained to avoid personal injury, prevent spills and releases, and make sure hazardous wastes are disposed of safely. Training records shall be maintained by the factory and made available to Assessors.

**IA** Factories shall develop and implement a written emergency plan that includes procedures to be followed if there is a spill or other event that releases hazardous waste from its container.

**IA** Hazardous waste “manifests” or other equivalent shipping documents shall be used with every hazardous waste shipment to an off-site location. Shipping documents used for hazardous wastes shall contain, at a minimum, the following information:

- Factory name and address
- Name, address, and phone number of the transporter and the designated recycling, treatment or disposal (destination) facility
- Description of each waste stream transported off-site for disposal

Shipping documents must be signed by factory personnel who have been trained on the hazardous waste shipping and documentation requirements.

**IA** Factory personnel shall track all waste shipments to verify that the shipments were received by the designated facility.

**IA** Waste disposal records shall be kept by the factory for at least three years (or longer, if required by local authorities).

**IA** Electrical equipment that may contain polychlorinated biphenyls (PCBs), such as transformers, regulators, capacitors, etc., shall be labeled and managed as PCB- PCB-contaminated equipment

**C1** In areas where permitted hazardous waste treatment, recycling, or disposal facilities are not readily available, factories shall consider on-site treatment by incineration, provided the incinerator is equipped with air pollution control equipment and is permitted by applicable federal, state, provincial, and/or local authorities.

- CI** Factories shall take steps to reduce hazardous waste (e.g., by using non-hazardous materials such as citrus-based solvents and non-toxic cleaners). Factories shall work to improve current procedures and technologies for hazardous waste reduction, treatment, recycling, and disposal.

## Implementation of Requirements

### Training, Rules and Record Keeping

- Factories should be familiar with local laws and regulations governing the management of hazardous waste and comply with all applicable requirements, as well as with best management practices.
- Workers who handle hazardous wastes should receive training on the following topics:
  - How to avoid personal injury when handling chemicals and wastes;
  - Waste container and labeling requirements;
  - Proper storage and handling procedures to prevent spills and leaks;
  - Weekly hazardous waste storage area inspections;
  - Approved disposal methods for each type of waste stream;
  - Filling out hazardous waste manifests or other equivalent shipping documentation;
  - Waste loading procedures (if performed by factory personnel);
  - Spill response and clean-up.
- Workers who are responsible for “containing” a spill (e.g., placing absorbent material around a spill to keep it from flowing off the property) or cleaning up a spill shall be trained on spill clean-up procedures, including how to protect themselves from contacting the spilled waste.
- If the factory has made arrangements with a qualified contractor(s) to clean up hazardous waste spills, employees should be trained to know what size spill they are allowed to clean up (e.g., one gallon or less if the waste is not extremely hazardous) and how to contain larger spills before the spill response contractor arrives.
- Factories should maintain written records of the following:
  - Personnel Training
  - Emergency Plans
  - Manifests or other shipping documentation
  - Waste Tracking (written verification from the designated treatment, recycling or disposal facility that the waste shipment was received, and the waste was managed according to instructions)
- Audits of hazardous waste treatment, recycling, or disposal facilities to verify that they are qualified and have all the necessary permits.
- Documentation showing any factory efforts to reduce waste generation.

### Hazard Assessment

- Factories should identify the types and amounts of hazardous wastes generated as a result of production and business activities and determine the waste disposal method for each waste stream.
- Factories should use hazardous waste identification records to (1) evaluate options for reducing or eliminating wastes and (2) track the factory’s progress in reducing waste.
- Factories should audit hazardous waste recycling, treatment, or disposal facilities before sending hazardous wastes to them. This audit should determine if the facility:
  - is secure from public access (i.e., fenced, gated);
  - manages wastes responsibly;
  - has all the required permits;
  - complies with its permit conditions, including keeping records on file; and
  - has the financial ability to pay for a spill clean-up or the closing down of its site.

### Hazard Controls

- Factories should establish written waste disposal procedures that include, at a minimum, the following specific requirements:
  - Hazardous wastes must be identified, placed in proper containers, labeled, stored in specially designated areas, secure from unauthorized entry, and disposed of in a manner that minimizes harm to human health and the environment.
  - Hazardous wastes shall only be handled by trained personnel.
  - Hazardous wastes must never be disposed of in a nonhazardous waste landfill, solid waste landfill, or local “dump.”
  - Hazardous wastes must never be co-mingled or mixed with non-hazardous waste. [If regular trash is mixed with hazardous waste, the entire waste must be managed as hazardous waste, resulting in unnecessary hazardous waste generation, higher disposal costs, and increased risk to factory employees and the surrounding community.]
  - Used oil must not be thrown in the trash, discarded to land, or mismanaged in a way that could cause it to enter waterways or the groundwater system or cause harm to human health or the environment. Used oils shall instead be recycled or reprocessed and used, for example, in furnaces for heat or in power plants to generate electricity.
  - Medical waste (including any waste contaminated with blood and human tissue) shall be collected in marked “Medical Waste” containers/bags. Sharps, such as contaminated sewing needles or hypodermic needles, shall be collected in containers marked as “Medical Waste Sharps” to prevent injury to those who handle the waste.



**Good Practice: Secure controlled landfill with guarded access and fenced perimeter**

- Hazardous wastes that pose a unique hazard if they are not completely destroyed, such as discarded dry chemical bags, shall be incinerated and not disposed of in a landfill.
- Empty hazardous material containers must be managed in a way that prevents a risk to human health and the environment. (See the best management practices for empty containers below.) Empty containers must never be given to the public or to employees for their personal use.
- All hazardous wastes should be placed in containers that are in good condition and are compatible with their contents (e.g., acid or caustic wastes must not be stored in metal drums, as they will corrode the metal). Containers should be covered except when workers are transferring hazardous waste into them.
- Hazardous waste containers should be labeled with the words, “HAZARDOUS WASTE,” the name of the waste (e.g., the chemical name), and the hazardous properties (such as flammable or caustic).
- Hazardous wastes should be stored in assigned areas with secondary containment (a container or physical structure that surrounds the primary container and serves to hold any liquids that may leak from the primary container).
- Assigned hazardous waste storage areas shall be:
  - located indoors, if possible (outdoor areas shall be completely enclosed, such as a shed);
  - locked to prevent unauthorized individuals from entering;
  - labeled with warning signs, such as: “WARNING— HAZARDOUS WASTE”; and
  - properly ventilated.
- Incompatible wastes should be segregated (e.g., incompatible wastes stored in a common area must have separate secondary containment structures to prevent mixing of incompatible waste streams).
- Authorized and trained factory workers should inspect assigned hazardous waste storage areas each week to make sure containers are in good condition and the requirements for hazardous waste are being met. [See Appendix for a sample “[Hazardous Waste Storage Area Weekly Inspection Checklist](#)”.]
- Spill control equipment should be kept in the assigned hazardous waste storage areas and inspected routinely to make sure adequate



**IA** Incompatible wastes stored in a common area must have separate secondary containment structures to prevent mixing of incompatible waste streams.

supplies are on hand in the event of a spill or release.

- The factory should develop and implement a written hazardous waste emergency plan to be

followed if there is a spill or other event that releases hazardous waste from its container. [See [Appendix](#) for a sample “[Hazardous Waste Emergency Plan](#).”]

- Emergency phone numbers (such as the numbers for the clean-up contractor and for local authorities who respond to fires or chemical spill emergencies) should be posted next to the telephone in the hazardous waste storage area. [See the Appendix for sample “Emergency Procedures” to post.]
- Factories that treat wastes on-site by incineration should do all of the following:
  - equip the incinerator with air pollution control equipment;
  - obtain all necessary permits from federal, state, provincial, and/or local authorities;
  - comply with all permit conditions associated with the incineration unit; and
  - dispose of incineration wastes at a permitted, secure hazardous waste landfill.
- The factory should establish a procedure for managing empty hazardous material containers to prevent them from being misused for personal purposes. The procedure shall address the following requirements:
  - Empty all chemical containers as much as possible.
  - If feasible, return empty containers to the original suppliers for recycling or re-use.
  - If it is not feasible to return empty containers to the original supplier, use the following best management practices:
    - o Triple-rinse containers that formerly held substances that may be disposed of to the sewer or to the on-site treatment plant (such as water-based detergents). Once containers are clean and dry, they may be recycled as nonhazardous solid waste.
    - o Make sure that chemical solvent or flammable material containers (that cannot be triple-rinsed because of sewer and/or on-site treatment plant restrictions) are drained completely dry. Factory personnel should poke holes in the plastic containers so they may never be re-used.
    - o Containers with residual chemicals shall be disposed of as hazardous waste.

---

## SOLID WASTE MANAGEMENT

“Solid waste” is a term that includes municipal wastes (general trash), debris, liquid industrial wastes, special wastes such as used oil and medical waste, and hazardous wastes. The benefits of reducing the volume of solid waste generated at a factory include a positive effect on the environment, an economic advantage to the factory and better community relations. The purpose of this section is to describe the requirements for managing and reducing the volume of solid waste generated by factories.

### Requirements for Solid Waste Management

- IA** Factories shall return surplus LS&Co. branded tags, buttons, and zippers to LS&CO, unless specifically instructed by LS&Co. to destroy them. These items may NOT be disposed of in a landfill, thrown in the general trash, or buried on site. Where factories are instructed to destroy these materials, they shall obtain and keep a “certificate of destruction” for the materials from the facility that destroys them.
- IA** Factories shall identify the local requirements (if any) for recycling containers and manage them accordingly (e.g., separate glass, plastic, and aluminum). Factories shall use permitted recycling facilities (e.g., glass, plastics, metals recyclers, or municipal waste disposal facilities that have a recycling program), wherever feasible.
- IA** Hazardous wastes—including medical waste and used oil— shall meet the requirements of the Hazardous Waste section and must never be mixed with general waste.
- CI** Factories shall create and implement a program to reduce the amount of solid waste they create, increase reuse or recycling of materials, and properly manage, store and dispose of all wastes. The program shall include setting waste reduction goals.
- CI** Used metal items such as scissors, metal carts, blades, sewing machine needles, etc. shall not be disposed of in a landfill, but instead recycled.
- CI** If there are no permitted recycling facilities in their vicinity, factories shall consider and investigate the use of local vendors or merchants who will accept non-hazardous recyclable materials.
- CI** Factories shall evaluate their procedures and technologies for managing solid waste each year and update these, when necessary, to improve the program and/or achieve goals.

---

## Implementation of Requirements

### *Training, Rules and Record Keeping*

- The factory’s solid waste program should be guided by the principle of REDUCE, REUSE, and RECYCLE. Workers should be encouraged to participate in the program to help the factory save resources and money.
- Factories should adhere to the suggested disposal methods for common types of solid wastes, listed below. More detailed information about how to reduce waste is included in the Appendix.

### LS&Co. Brand Materials

Buttons, zippers, or tags may never be thrown in the trash or disposed of in a landfill. Factories shall return all buttons, zippers, and tags to LS&Co., unless specifically instructed by LS&Co. to destroy these items by incinerating zippers and shredding tags.

Whenever factories destroy LS&Co. branded buttons, zippers, and/or tags (instead of returning them to LS&Co.), factories shall obtain a “certificate of destruction” from the designated facility for each waste load sent off-site for incineration (buttons and/ or zippers) or shredding (tags). Certificates of destruction should be maintained on file by the factory and made available to Assessors for review.

### Factory Equipment

Factory equipment includes any electrical device or machine used in the process of producing apparel, such as a sewing machine and/or a cutting machine, as well as computer and other electronic equipment. When equipment is no longer in useful condition, the factory should reuse or recycle the internal components, wherever feasible, rather than simply disposing of the entire machine in a landfill.

**Caution:** Some equipment may contain hazardous materials, such as mercury or polychlorinated biphenyls (PCBs). All equipment containing hazardous materials, such as mercury or PCBs, shall be removed and then properly managed as hazardous waste. (See the Hazardous Waste section for details.)

### Food

There are many methods of reducing the solid waste created by the factory’s food service. Examples include buying food supplies frequently (“just-in-time buying”) to make sure the food does not spoil; and using washable and reusable dishes, cutlery and linen. Food waste shall be collected and provided to a composting facility.

## Office Supplies

Every effort shall be made to recycle all office paper. Most types of paper are recyclable, including computer printout (colored or blank), white ledger, colored ledger, manila folders, pamphlets, brochures, phone books and newspapers. Examples of paper that cannot be recycled are paper with food contamination and blueprints.

## Plastic Covering

Plastic coverings should be collected and recycled, wherever feasible. The plastic is low-density polyethylene (LDPE) and can be reprocessed to agricultural film, shopping bags and/or packaging film.

## Material Waste

Factories should minimize the amount of lost material. Material that is unused or damaged can be reused and/or recycled for other purposes. Scraps can be used for cleaning tasks—wiping down machines,

for example. Scraps can also be collected and sold or given to a company to be used as stuffing for cushions and pillows. Unused material can be used as padding for carpet underlay, mattress padding and the molded padding used in the automotive industry.



**IA Bad Practice: Hazardous waste shall never be disposed of at a landfill with uncontrolled access. Hazardous waste landfills must be secured to prevent scavengers.**

## Thread and Cones

Factories should use all thread in production and avoid having it go to waste. Thread cones should be returned to the supplier or manufacturer for reuse.

## Cardboard Boxes

Cardboard should be properly recycled. Recycled cardboard is used to manufacture new boxes, paper tubes, cans and drums, gypsum wall and many other products.

## Wooden Crates and Pallets

Broken wooden crates and pallets can be reused or recycled. Wherever possible, used pallets should be returned to the vendor to be repaired and reused. If pallets are broken and uncontaminated, they may be recycled by a composting company for use as mulch.

## Glass/Plastic/Aluminum Containers

Glass, plastic, and aluminum containers should be recycled, wherever feasible. Factories should identify the local requirements (if any) for recycling these containers and manage them accordingly (e.g., separate glass, plastic, and aluminum).

Containers that formerly held hazardous materials should be managed as hazardous waste (see the Hazardous Waste section for details).

## Hazardous Waste

Examples of hazardous wastes include: spent chemicals such as bleaching materials, solvent-based paint, flammable solvents and caustic cleaners; used oil; spent batteries, ballasts, and fluorescent/high-intensity discharge lamps; medical wastes, and pesticides.

Hazardous waste shall never be disposed of with

general waste. All hazardous waste shall be managed according to the requirements of the Hazardous Waste section.



**IA Bad Practice: Construction waste, garbage, chemicals, and discharge from pipe all commingling in one pond. All waste must now be treated as hazardous.**

# Annex A: Safety Guidelines

## SAFETY COMMITTEES

### Sample Safety Committee Mission Statement

#### Purpose

The purpose of the \_\_\_\_\_ (factory name) Safety Committee (“the committee”) is to promote a safe working environment at the factory name of factory with worker involvement. The committee will give workers a direct voice in addressing safety concerns throughout the factory. Workers who become members of the committee will have the opportunity to work closely with management staff in solving critical problems. The members will be the representatives of all other workers and should be the contacts for workers who have safety concerns.

#### Membership

The committee will consist of \_\_\_\_\_ (number) workers from all areas of the factory that will work directly with [list the management members and number, including the Health and Safety Coordinator]. The committee members will meet monthly for approximately one hour to discuss safety concerns. It is important for workers who become members of this committee to have:

- good attendance and work records,
- a good attitude,
- good communication skills,
- motivation and a concern for safety.

The committee members will elect two Leaders (one worker and one management representative) and a Secretary for the committee. The Leaders are responsible for running the meetings and will report to factory management on the activities of the committee. It will be the Leaders’ responsibility to develop an agenda for each meeting and ensure that it is followed. It is also the Leaders’ obligation to ensure that all safety concerns that are raised are followed through to an end result. The Secretary is responsible for recording the minutes of each meeting and distributing copies of these minutes to all members and to factory management in a timely manner. The Secretary is also responsible for posting the minutes in a location(s) that allows them to be read by the factory worker population.

The committee will need to set the terms for serving on this committee for each member. Most committee members will serve for no more than three years, with the normal term running two years. Terms for each member will need to be staggered so that a complete turnover of the committee does not occur at one time. When there is a vacant position on the committee, the factory will solicit nominations, and it will be the responsibility of the committee to select new members from the nominations received. The committee will have very strict guidelines for attendance at committee meetings and if any member misses three consecutive meetings without a valid excuse, they will be dismissed from the committee.

#### Responsibilities

The committee will tour work areas throughout the factory with the Health and Safety Coordinator to familiarize all members with the different types of jobs workers do and their work environment. The committee will work to identify areas where workers are at risk either through direct experience, through observation (during routine inspections) or through concerns brought to their attention by other workers. They will address the various issues identified and offer suggestions. The committee will conduct investigations of incidents (accidents, environmental incidents, near misses) that occur at the factory to identify root causes and appropriate corrective actions. The committee will also review safety suggestions made by other workers. It will be the committee’s responsibility to prioritize the concerns and present their plans and suggestions to management. In addition, the members will do an annual review of all training programs related to safety and offer continual improvement suggestions.

Being a member of this committee is a very serious role. The cooperative effort between workers and management typically results in higher morale, lower accidents and injury rates, reduced workers’ compensation costs, and joint ownership of the safety improvement process. Worker involvement is integral to creating a safe working environment.

### Example procedure for identifying workplace hazards

- a. Risk assessment performed as required by law (not less than once every 2 years)
- b. Procedures are implemented
- c. Employees are trained
- d. Every activity is assessed at periodically by H&S competent person

### Examples of Risk Assessment Minimum Requirements

- a. Fire risk
- b. Use of electricity
- c. Delivery and storage of stock
- d. Workplace health and safety arrangements in work floor
- e. Employment of persons under 18
- f. Pregnant or nursing mothers
- g. Working at height
- h. Slips, trips and falls
- i. Manual handling
- j. Stress
- k. Machinery (e.g., sewing machines, steamers, irons, boilers, etc.)
- l. Display screen equipment
- m. Chemicals and banned substances
- n. Minimum property requirements including:
- o. Separate break area including kitchenette
- p. Storage area
- q. Toilets available as legally required and in good condition
- r. If the local requirements exceed above standards these should be included

### Example Safety Committee Agenda

- a. Attendance
- b. Minutes of last meeting (circulated prior to meeting)
- c. New issues/matters (only if not on this agenda)
- d. Report from Health and Safety Coordinator
- e. Regular items: Incident Investigations, Inspection Results, Metrics (e.g., training attendance, injury rate, etc.)
  - Progress towards improving systems
- f. Outstanding issues from previous meetings
- g. Scheduling next meeting

#### Use the Agenda:

- To keep track of issues from meeting to meeting
- As a template for minutes
  
- To publicize dates/times and issues to factory managers and workers

## EMERGENCY PREPAREDNESS

### Contents

1. Sample Fire Prevention Plan
2. Sample Earthquake Preparedness Procedure
3. Sample Shelter-in-Place Procedure

### Purpose

The \_\_\_\_\_ (factory name) Fire Safety Plan has been developed to work with company emergency plans and other safety programs. All new building construction and renovations should be reviewed to ensure compliance with applicable state, local, and national fire and life safety standards. Fire prevention measures reduce the incidence of fires by eliminating opportunities for flammable materials to ignite.

### Responsibilities

#### Management

- Make sure all fire prevention methods are established and enforced.
- Make sure fire suppression systems such as sprinklers and extinguishers are inspected at least monthly and maintained to a high degree of working order.
- Train all workers to use fire extinguishers for fires that are just beginning.
- Train workers on evacuation routes and procedures.
- Supervisors
- Closely monitor the use of flammable materials and liquids.
- Train assigned workers to safely store, use and handle flammable materials.
- Make sure areas where flammable materials are stored are properly maintained.

#### Workers

- Use, store and transfer flammable materials following procedures provided in training.
- Do not mix flammable materials.
- Immediately report violations of the Fire Safety Program.

#### Hazards

Fire and explosion hazards can exist in almost any work area. Potential hazards include:



- 
- Improper operation or maintenance of gas-fired equipment

- Improper storage or use of flammable liquids
- Smoking in prohibited areas
- Accumulation of trash
- Hot Work (welding, soldering, any use of open flame or torch) operations without proper controls.

## Hazard Controls

### Eliminate Ignition Sources

All non-essential ignition sources should be eliminated where flammable liquids are used or stored. The following is a list of some of the more common potential ignition sources:

- Open flames, such as cutting and welding torches, furnaces, matches, solder guns, and heaters—these sources should be kept away from flammable liquids operations. Cutting or welding on flammable liquids equipment should not be performed unless the equipment has been properly emptied and purged with a neutral gas such as nitrogen.
- Chemical sources of ignition such as d.c. motors, switches, and circuit breakers—these sources should be eliminated where flammable liquids are handled or stored. Only approved explosion-proof devices should be used in these areas.
- Mechanical sparks—These sparks can be produced as a result of friction. Only non-sparking tools should be used in areas where flammable liquids are stored or handled.
- Static sparks—these sparks can be generated as a result of electron transfer between two contacting surfaces. The electrons can discharge in a small volume, raising the temperature to above the ignition temperature. Every effort should be made to eliminate the possibility of static sparks. Also, proper bonding and grounding procedures should be followed when flammable liquids are transferred or transported.

### Remove Incompatibles

Materials that can contribute to a flammable liquid fire should not be stored with flammable liquids. Examples of such materials include oxidizers and organic peroxides, which, on decomposition, can generate large amounts of oxygen.

### Control Flammable Gases

Generally, flammable gases pose the same type of fire hazards as flammable liquids and their vapors. Many of the safeguards for flammable liquids also apply to flammable gases; other properties such as toxicity, reactivity, and corrosiveness also should also be taken into account. For example, a gas that is flammable could produce toxic combustion products.

## Fire Extinguishers

A portable fire extinguisher is a “first aid” device and is very effective when used while the fire is small. The use of a fire extinguisher that matches the class of fire, by a person who is well trained, can save both lives and property. Portable fire extinguishers should be installed in workplaces regardless of other fire-fighting measures. The successful performance of a fire extinguisher in a fire situation largely depends on its proper selection, inspection, maintenance, and distribution.

### *Classification of Fires and Selection of Extinguishers*

Fires are classified into four general categories depending on the type of material or fuel involved. The type of fire determines the type of extinguisher that should be used to extinguish it:

- Class A fires involve materials such as wood, paper, and cloth, which produce glowing embers or char.
- Class B fires involve flammable gases, liquids, and greases, including gasoline and most hydrocarbon liquids, which should be vaporized for combustion to occur.
- Class C are fires in live electrical equipment or in materials near electrically powered equipment.
- Class D fires involve combustible metals such as magnesium, zirconium, potassium, and sodium.

Extinguishers should be selected according to the potential fire hazard, the construction and occupancy of facilities, the hazard to be protected, and other factors pertinent to the situation

### *Location and Marking of Extinguishers*

Extinguishers should be conspicuously located and readily accessible for immediate use in the event of fire. They should be located along normal paths of travel and egress. Extinguishers should be clearly visible. In locations where visual obstruction cannot be completely avoided, directional arrows will be provided to indicate the location of extinguishers, and the arrows will be marked with the extinguisher classification.

If extinguishers intended for different classes of fire are located together, they should be conspicuously marked to ensure that the proper class of extinguisher is selected at the time of a fire. Extinguisher classification markings should be located on the front of the shell above or below the extinguisher nameplate. Markings should be of a size and form to be legible from a distance of 1 meter (about 3 feet).

### *Condition*

Portable extinguishers should be maintained in a fully charged and operable condition. They should be kept in their assigned locations at all times when not being used. When extinguishers are removed for maintenance or testing, a fully charged and operable replacement unit should be provided.

---

### **Mounting and Distribution of Extinguishers**

Extinguishers should be installed on hangers, brackets, in cabinets, or on shelves.

Extinguishers mounted in cabinets or wall recesses or set on shelves should be placed so that the extinguisher operating instructions face outward. The location of such extinguishers will be made clear by marking the cabinet or wall recess in a contrasting color which will distinguish it from the normal decor.

Extinguishers should be distributed in such a way that the amount of time needed to travel to their location and back to the fire does not allow the fire to get out of control. The travel distance for Class A and Class D extinguishers should not exceed 23 meters (75 feet).

The maximum travel distance for Class B extinguishers is 15 meters (50 feet) because flammable liquid fires can get out of control faster than Class A fires. There is no maximum travel distance specified for Class C extinguishers, but they should be distributed on the basis of appropriate patterns for Class A and B hazards.

### **Inspection and Maintenance**

Once an extinguisher is selected, purchased, and installed, it is the responsibility of [names/titles of individuals assigned this responsibility] to oversee the inspection, maintenance, and testing of fire extinguishers to ensure that they are in proper working condition and have not been tampered with or physically damaged.

### **Fire Safety Inspections & Housekeeping**

\_\_\_\_\_ (Title of individuals assigned this responsibility) \_\_\_\_\_ are responsible for observing worksite safety and housekeeping issues and should specifically address proper storage of chemicals and supplies, unobstructed access to fire extinguishers, and emergency evacuation routes. Also, they should determine if an emergency evacuation plan is present in work areas and if personnel are familiar with the plan.

\_\_\_\_\_ (Title of individuals assigned this responsibility) \_\_\_\_\_ will be responsible for ensuring a monthly fire safety inspection of the facility is conducted. This includes valve inspections, flow tests of the risers, audible and visual alarm activation, inspection of sprinkler heads, emergency lighting, general order and housekeeping. It also includes checking that combustible materials are removed daily, that flammable liquids are stored safely, that spill kits are intact at specific locations and that electrical equipment is in good repair.

---

### **Emergency Exits**

Every exit will be clearly visible, or the route to it clearly identified in such a way that every occupant of the building will readily know the direction of escape from any point. At no time will exits be blocked.

Any doorway or passageway which is not an exit or access to an exit, but which may be mistaken for an exit, will be identified by a sign reading "Not An Exit" or a sign indicating its actual use (i.e., "Storeroom"). Exits and accesses to exits will be marked by a readily visible sign. Each exit sign (other than internally illuminated signs) will be illuminated by a reliable light source providing not less than 50 lux on the illuminated surface.

### **Emergency Plan for Persons with Disabilities**

Supervisors are assigned the responsibility of assisting persons with disabilities under their supervision. An alternate assistant will be chosen by the supervisor. The role of the assistants is to report to their assigned person in an emergency, and to either assist in evacuation or assure that the person is removed from danger.

- Supervisors, alternates, and the person with a disability will be trained on available escape routes and methods.
- Visitors who have disabilities will be assisted in a manner similar to that of factory workers. The host of the person with disabilities will assist in their evacuation.

### **Emergencies Involving Fire**

#### **Fire Alarms**

In the event of a fire emergency, a fire alarm will sound \_\_\_\_\_ (include any description of sound) \_\_\_\_\_ for the building.

#### **Evacuation Routes and Plans—See *Emergency Evacuation Plan***

\_\_\_\_\_ (Name of Supplier) \_\_\_\_\_ will have an emergency evacuation plan. All emergency exits should conform to codes and standards. Should evacuation be necessary, go to the nearest exit and proceed to the assigned area outside the building.

#### **Supervisors and Coordinators**

Supervisors and Coordinators will be responsible for checking that all personnel have evacuated from their assigned areas.

---

## Fire Emergency Procedures

### If you discover a fire:

1. Activate the nearest fire alarm.
2. Notify your Supervisor and other occupants.

### Fight the fire ONLY if:

1. The fire department has been notified of the fire, AND
2. The fire is small and confined to its area of origin, AND
3. You have a way out and can fight the fire with your back to the exit, AND
4. You have the proper extinguisher, in good working order,
5. AND have been trained and know how to use it.
6. If you are not sure of your ability or the fire extinguisher's capacity to contain the fire, leave the area.

### If you hear a fire alarm:

1. Evacuate the area, and close doors as you leave.
2. Leave the building and move away from exits and out of the way of emergency operations.
3. Assemble in an assigned area, outside the building.
4. Supervisors and Coordinators should account for all workers in their area to determine that all personnel have evacuated.
5. All workers should remain outside until given the signal or
6. announcement that it is safe to re-enter.

### Evacuation Routes:

1. Learn at least two escape routes and emergency exits from your area.
2. Learn to activate a fire alarm.
3. Learn to recognize alarm sounds.
4. Take an active part in fire evacuation drills.

---

## Evacuation

### Fire

- When the alarm sounds, all personnel not assigned to emergency duties will immediately proceed to the nearest SAFE exit. Leave the building and move directly to the nearest assembly area.
- Do not stop to pick up personal items.
- All personnel should refrain from smoking during the evacuation.
- All personnel should be at least sixty meters (60 m) or two hundred feet (200 ft) away from the building.
- Be familiar with exit routes, assembly areas, and evacuation maps.
- Report to assembly area coordinator if evacuating from other than your normally assigned location, also report to assembly area coordinator if co-worker is missing.
- Treat all alarms as if there is an emergency situation. Factory will evacuate for all alarms.

### Power Failure

- In the event of a power failure, remain in your work area. Wait for instruction from your coordinator, Supervisor, or shift leader.
- STOP and park all moving equipment immediately for the duration of the power failure (this includes golf/ utility carts and bicycles).

### List of Potential Fire Hazards

Flammables	Location	Handling Procedure	Storage Procedure
Flammable Chemicals Diesel Fuel	[insert location]	Trained Personnel only	Kept in flammable cabinets when not in use.
	[insert location]	Trained Personnel, Contracted Fuel Delivery Company	Protected tanks, with secondary containment, isolated from ignition sources.







Processes	Location	Precautionary Steps	Storage Procedure
Welding, cutting, grinding	[insert location]	Isolated area with local ventilation, fire- rated walls	Compressed gas cylinders secured properly to structure or cart, stored in welding area.
	[insert location]	Hot work permit system	

Combustibles	Location	Handling Procedure	Storage Procedure
Cartons, pallets, garments, sundries, trash	[insert location]	All items isolated from ignition sources, hot work permit system	Cartons, pallets, garments, sundries stored in compliance with local ordinances, in warehouse equipped with automatic sprinklers. Trash stored outside in covered dumpster emptied regularly.

Reactives	Location	Handling Procedure	Storage Procedure
Sulfuric Acid	Battery Charging Area	Trained Personnel wearing proper personal protective equipment	Acid only contained in batteries themselves

### Types of Fires and Fire Extinguisher Ratings

There are four classes of fires, categorized according to the kind of material that is burning. There are two sets of color-coded icons in common use. One or both types of icons appear on most fire extinguishers to indicate the kinds of fire against which the unit is intended to be used. There is only one icon used to indicate the fourth (class D) kind of fire. Class D fires involve uncommon materials and occur in fairly specialized situations. Note that any given fire can fall into more than one class; a fire that involves both burning paper and kitchen grease would be a Class AB fire.

	Picture Designator	Old Style Label
<p><b>Class A fires</b> are those fueled by materials that, when they burn, leave a residue in the form of ash, such as paper, wood, cloth, rubber and certain plastics.</p> <p><b>Class A Extinguishers</b> will put out fires in ordinary combustibles, such as wood and paper.</p>		
<p><b>Class B fires</b> involve flammable liquids and gases, such as gasoline, paint thinner, kitchen grease, propane, and acetylene.</p> <p><b>Class B Extinguishers</b> should be used on fires involving flammable liquids, such as grease, gasoline, oil, etc.</p>		
<p><b>Class C fires</b> involve energized electrical wiring or equipment (motors, computers, panel boxes). Note that if the electricity to the equipment is cut, a Class C fire becomes one of the other three types of fires.</p> <p><b>Class C Extinguishers</b> are suitable for use on electrically energized fires. This class of fire extinguishers does not have a numerical rating. The presence of the letter "C" indicates that the extinguishing agent is non-conductive.</p>		
<p><b>Class D fires</b> involve exotic metals, such as magnesium, sodium, titanium, and certain organometallic compounds such as alkyllithium and Grignard reagents.</p> <p><b>Class D Extinguishers</b> are designed for use on flammable metals and are often specific for the type of metal in question. There is no picture designator for Class D extinguishers.</p>	NONE	

---

## Earthquake Preparedness Procedures

### Earthquake Preparation

- Search for hazards in your work areas; eliminate them where possible and know how to protect yourself.
- Keep earthquake supplies on hand, at or near your workstation. An individual kit, stored in a backpack, should include a 72-hour supply of the following:
  1. Sturdy, hard-soled, close-toed shoes
  2. Essential medications
  3. Spare prescription glasses
  4. Warm clothing
  5. Flashlight and batteries
  6. Battery-powered radio
  7. Bottled water
  8. Non-perishable foods in sealed containers

### During an Earthquake

#### *Inside the building:*

- Stay calm. Seek cover. Get under a sturdy table or desk; protect your hands by keeping them off the floor.
- Stay clear of tall objects and windows.
- Once the initial shocks have subsided, stay under cover.
- When it is safe to do so, assist the injured.
- Check for potential safety and fire hazards.
- Evacuate the building only if instructed to do so.
- Always use stairs—elevators are a potential trap in an earthquake.
- When you move, be careful—the greatest danger from falling debris is just outside doorways, on the outer walls of a building or room.
- Be prepared for aftershocks.

#### *If outside:*

- Get out into the open.
- Move away from power lines and tall buildings, if possible.
- Get down and protect your face and head with your arms or an object such as a newspaper, blanket or coat.
- Do not enter any building, even after the shaking has stopped, until local authorities have said it is safe.

---

### After an Earthquake

- Check your immediate location; are you safe?
- Use flashlights; do not light matches or ignite flames.
- Check for injuries of others and report to emergency personnel.
- Be prepared for aftershocks.
- Put on sturdy shoes to protect yourself from broken glass and debris.
- Do not relocate to another floor or evacuate until safe to do so.
- If you smell gas or see broken pipe, report it immediately to security guards or emergency personnel.
- Be prepared to go without public emergency services and to ration food and water.

## Sample Shelter-in-Place Procedure

### Shelter Areas

The following areas have been assigned as shelter areas in case of severe weather or other emergencies requiring shelter-in place:

\_\_\_\_\_ (name/location)

\_\_\_\_\_ (name/location)

\_\_\_\_\_ (name/location)

### Shelter-in-Place Procedure

- Become familiar with your primary shelter area.
- Become familiar with the sound of the shelter-in-place alarm. When the shelter-in-place alarm sounds, walk in an orderly fashion toward the nearest shelter area.
- If directed to relocate to another area, follow and wait for further instructions.
- Stay in your shelter area until the signal has been given that it is safe to leave.

## AISLES AND EXITS

### Aisles and Exits Checklist

	Requirement	Meet Requirement?	
<b>Exit Doors</b>	The floor on each side of the exit doors should be level. (The floor surfaces on both sides of a door should not vary in height by more than 1.3 cm [0.5 in].)	<input type="checkbox"/> Yes	<input type="checkbox"/> No
	If doors do not swing open at least 90 degrees, the width of the doorway should be measured between the face of the door and the door stop. This width should be at least 91 cm (36 in).	<input type="checkbox"/> Yes	<input type="checkbox"/> No
	Exit doors should swing in the direction of the way out from the building (generally outward).	<input type="checkbox"/> Yes	<input type="checkbox"/> No
	Exit doors should not be equipped with locks or keys or other mechanisms which require special knowledge or effort to operate.	<input type="checkbox"/> Yes	<input type="checkbox"/> No
	The door-latch release mechanism should be located at least 86 cm (34 in), but no more than 122 cm (46 in), above the floor.	<input type="checkbox"/> Yes	<input type="checkbox"/> No
	Exit doors should release easily to the outside. It should not take more than 67 N (15 lbf) of manual force to fully open any exit door.	<input type="checkbox"/> Yes	<input type="checkbox"/> No
	All exits should end in an outdoor public way.	<input type="checkbox"/> Yes	<input type="checkbox"/> No
<b>Stairs</b>	Stairwell doors should allow a worker to re-enter from the stairwell.	<input type="checkbox"/> Yes	<input type="checkbox"/> No
	Stairs that serve as an exit route should be of permanent, fixed construction. Stairs that exit the building that are more than 76 cm (30 in) above the floor should have guards that are at least 107 cm (42 in) high to prevent workers from falling over the open side.	<input type="checkbox"/> Yes	<input type="checkbox"/> No
	Stairs should be at least 112 cm (44 in) wide and at least 10-19 cm (4"-7 1/2" in) high. Stairs and ramps should have handrails on both sides. Existing handrails should not be less than 76 cm (30 in) high. New handrails should be at least 86 cm (34 inches) and not more than 96 cm (38 in) high.	<input type="checkbox"/> Yes	<input type="checkbox"/> No

	Requirement	Meet Requirement?	
<b>Stairs</b>	Handrails should have an outside diameter of not less than 3.2 cm (1.25 in) and no more than 5 cm (2 in). Handrails should be located a distance of 5.7 cm (2.25 in) from the adjacent wall or other point of contact.	<input type="checkbox"/> Yes	<input type="checkbox"/> No
	For buildings with one to three levels, the exit corridors and stairwells should be able to contain a fire and stay intact for at least one hour in a fire situation. There should be at least two exits on each floor that are located as far away from one another as is practical.	<input type="checkbox"/> Yes	<input type="checkbox"/> No
<b>Exit Routes</b>	The maximum distance for a worker to travel to an exit should be no more than 61 m (200 ft) in a building that does not have fire sprinklers. This distance may be no more than 76 m (250 ft) in a building that has fully automatic sprinklers. Corridors with only one exit may not be longer than 15 m (50 ft).	<input type="checkbox"/> Yes	<input type="checkbox"/> No
	All exit routes should have at least 10.7 lux (one foot-candle) of light.	<input type="checkbox"/> Yes	<input type="checkbox"/> No
	Emergency lighting should be provided by battery-powered units or generators that can run for 1.5 hours. Emergency lighting should operate automatically and provide at least 10.7 lux (one foot candle).	<input type="checkbox"/> Yes	<input type="checkbox"/> No
	The route to each exit should be clearly marked.	<input type="checkbox"/> Yes	<input type="checkbox"/> No

1N = Newton. 1 Newton is the amount of force required to accelerate a mass of one kilogram at a rate of one meter per second squared (kg \* m/s<sup>2</sup>).

2 Lbf = pound-force

## HOUSEKEEPING

### Housekeeping Checklist





Aspect	Housekeeping Item	Meet Requirement <sup>1,2</sup>	
<b>Buildings</b>	Walls and windows clean.	<input type="checkbox"/> Yes	<input type="checkbox"/> No
	Lint and combustible fiber regularly swept or vacuumed up.	<input type="checkbox"/> Yes	<input type="checkbox"/> No
	Walls free of unnecessary hangings.	<input type="checkbox"/> Yes	<input type="checkbox"/> No
	Proper light provided.	<input type="checkbox"/> Yes	<input type="checkbox"/> No
	Stairs clean and well lit. Handrails and steps are well constructed and well maintained.	<input type="checkbox"/> Yes	<input type="checkbox"/> No
<b>Floors</b>	Clean and free of loose or scrap material. Clean in corners, behind radiators and other equipment, along walls, around pillars or columns.	<input type="checkbox"/> Yes	<input type="checkbox"/> No
	Free of oil, grease, other drips or spills.	<input type="checkbox"/> Yes	<input type="checkbox"/> No
	Free of unnecessary materials.	<input type="checkbox"/> Yes	<input type="checkbox"/> No
	Non-combustible containers, with lids, provided for waste. Waste regularly removed.	<input type="checkbox"/> Yes	<input type="checkbox"/> No
<b>Aisles</b>	Free of obstacles.	<input type="checkbox"/> Yes	<input type="checkbox"/> No
	Safe and free passage to fire-fighting equipment and exits.	<input type="checkbox"/> Yes	<input type="checkbox"/> No
	Safe and free access to workstations.	<input type="checkbox"/> Yes	<input type="checkbox"/> No
	Clearly marked.	<input type="checkbox"/> Yes	<input type="checkbox"/> No
<b>Machinery &amp; Equipment</b>	Clean and free of unnecessary material. Lint and combustible fiber regularly swept or vacuumed up.	<input type="checkbox"/> Yes	<input type="checkbox"/> No
	Free of dripping oil or grease.	<input type="checkbox"/> Yes	<input type="checkbox"/> No
	Area around machines is clean and free of rags, paper, etc.	<input type="checkbox"/> Yes	<input type="checkbox"/> No
	Lockers and cupboards clean and free of unnecessary material both on top and inside.	<input type="checkbox"/> Yes	<input type="checkbox"/> No
	Benches and seats clean and in good condition.	<input type="checkbox"/> Yes	<input type="checkbox"/> No
	Toilet facilities clean and well ventilated.	<input type="checkbox"/> Yes	<input type="checkbox"/> No
	Proper machine guards provided and in good condition.	<input type="checkbox"/> Yes	<input type="checkbox"/> No
	First-aid facilities and equipment fully stocked and in clean condition.	<input type="checkbox"/> Yes	<input type="checkbox"/> No
<b>Stock &amp; Material</b>	Properly piled and arranged.	<input type="checkbox"/> Yes	<input type="checkbox"/> No
	Neatly kept in storage areas.	<input type="checkbox"/> Yes	<input type="checkbox"/> No
	Storage areas clearly marked, kept in orderly condition.	<input type="checkbox"/> Yes	<input type="checkbox"/> No
	Storage does not block exits, first-aid stations, fire extinguishers, electrical panels, eyewash stations/showers, or sprinkler heads.	<input type="checkbox"/> Yes	<input type="checkbox"/> No
	Flammable, combustible, toxic and other hazardous materials are stored in approved containers in designated areas that are appropriate for the different hazards that they pose.	<input type="checkbox"/> Yes	<input type="checkbox"/> No



Aspect	Housekeeping Item	Meet Requirements?
<b>Tools</b>	Properly arranged in place.	<input type="checkbox"/> Yes <input type="checkbox"/> No
	Free of oil and grease.	<input type="checkbox"/> Yes <input type="checkbox"/> No
	Inspected and maintained in good order.	<input type="checkbox"/> Yes <input type="checkbox"/> No
	Tool room and racks in clean and orderly condition.	<input type="checkbox"/> Yes <input type="checkbox"/> No
<b>Grounds</b>	Building grounds are free of refuse such as food scraps, scrap metal, other waste material.	<input type="checkbox"/> Yes <input type="checkbox"/> No
	Waste materials removed frequently.	<input type="checkbox"/> Yes <input type="checkbox"/> No
	Outside storage is at least 25 m (7.5 ft) from building walls.	<input type="checkbox"/> Yes <input type="checkbox"/> No

## ELECTRICAL SAFETY

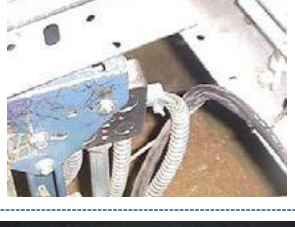
### Electrical Safety Inspection Checklist

Condition	Yes or No?	Corrective Action	Examples of Improper Conditions
Are <b>face plates</b> in good condition?	<input type="checkbox"/> Yes <input type="checkbox"/> No	Replace broken or cracked faceplates.	
Are <b>electrical cords</b> in good condition?	<input type="checkbox"/> Yes <input type="checkbox"/> No	Repair or replace cords with exposed wiring.	
Are <b>ground plugs</b> intact?	<input type="checkbox"/> Yes <input type="checkbox"/> No	Replace plugs that have broken ground plugs.	
Are connections to <b>junction boxes</b> secure?	<input type="checkbox"/> Yes <input type="checkbox"/> No	Repair connection to J-boxes so wires are not exposed.	
Are <b>knockouts to J-boxes</b> covered?	<input type="checkbox"/> Yes <input type="checkbox"/> No	Cover all J-box knockouts so internal wires are not exposed.	

**LOCK-OUT/TAG-OUT**

**Annual Inspection Checklist**

Name of authorized worker: \_\_\_\_\_ ID# \_\_\_\_\_

Description of machinery/equipment: \_\_\_\_\_

**Observe the authorized worker implementing the lock-out/tag-out procedure. Ensure he/she completes the following:**

- Notify affected personnel.
- Shut off the machine according to proper procedures; then assure the controls are in the OFF or NEUTRAL position.
- Separate the machine from ALL hazardous energy sources.
- Apply the lock-out/tag-out device(s) to the separation point(s).
- Assure the lock-out/tag-out is effective by attempting to start machine.
- Simulate/describe repairs.
- Assure area is clear of items that could cause an accident or problems.
- Replace all guards and safety devices.
- Remove lock-out/tag-out device(s).
- Restore power.
- Test machine with or without guards to assure it is working properly.
- Inform affected person(s) that lock-out/tag-out is no longer in effect.

**Ensure Authorized Worker is able to explain the following:**

- Group lock-out/tag-out
- Shift Change lock-out/tag-out
- Limitations of Tag-Only procedure
- Understanding of "Management Lock" procedures

**Authorized worker signature:** \_\_\_\_\_

**Inspector Name (print):** \_\_\_\_\_

**Title:** \_\_\_\_\_

**Annual Certification Form**

This document is to certify that an annual certification of the [Name of the Factory] Lock-Out/Tag-Out program has been conducted for the year \_\_\_\_\_. The following steps were taken to ensure the lock-out/tag-out program was effective and understood by all authorized workers.

- The lock-out/tag-out program was reviewed and revised by: \_\_\_\_\_
- All specific equipment procedures were reviewed and revised to ensure applicability and effectiveness.
- This was performed by: \_\_\_\_\_
- All authorized workers were trained using the revised program and the revised equipment-specific procedures.
- Each authorized worker participated in an inspection of the lock-out/tag-out procedures on specific equipment.

Health & Safety Coordinator \_\_\_\_\_ Date \_\_\_\_\_

Factory Manager \_\_\_\_\_ Date \_\_\_\_\_

---

## MACHINE GUARDING

### General

Any mechanical motion that threatens a worker's safety should not remain unguarded. The approaches to machine safeguarding discussed in this Handbook are not the only solutions which meet our requirements. Why? Because practical solutions to safeguarding moving machine parts are as numerous as the people working on them.

### Requirements for Safeguards

What must a safeguard do to protect workers against mechanical hazards? Safeguards should meet these minimum general requirements:

- **Prevent contact:** The safeguard should prevent hands, arms, and any other parts of a worker's body from making contact with dangerous moving parts. A good safeguarding system eliminates the possibility of the operator or another worker placing parts of their bodies near hazardous moving parts.
- **Secure:** Workers should not be able to easily remove or tamper with the safeguard, because a safeguard that can easily be made ineffective is no safeguard at all. Guards and safety devices should be made of durable material that will withstand the conditions of normal use. They should be firmly secured to the machine.
- **Protect from falling objects:** The safeguard should ensure that no objects can fall into moving parts. A small tool which is dropped into a cycling machine could easily become a projectile that could strike and injure someone.
- **Create no new hazards:** A safeguard defeats its own purpose if it creates a hazard of its own such as a shear point, a jagged edge, or an unfinished surface which can cause a laceration. The edges of guards, for instance, should be rolled or bolted in such a way that they eliminate sharp edges.
- **Create no interference:** Any safeguard which impedes a worker from performing the job quickly and comfortably might soon be overridden or disregarded. Proper safeguarding can actually enhance efficiency since it can relieve the worker's apprehensions about injury.
- **Allow safe lubrication:** If possible, one should be able to lubricate the machine without removing the safeguards. Locating oil reservoirs outside the guard, with a line leading to the lubrication point, will reduce the need for the operator or maintenance worker to enter the hazardous area.

---

### Training

Even the most elaborate safeguarding system cannot offer effective protection unless the worker knows how to use it and why. Specific and detailed training is therefore a crucial part of any effort to provide safeguarding against machine-related hazards. Thorough operator training should involve instruction or hands-on training in the following:



1. a description and identification of the hazards associated with particular machines;
2. the safeguards themselves, how they provide protection, and the hazards for which they are intended;
3. how to use the safeguards and why;
4. how and under what circumstances safeguards can be removed, and by whom (in most cases, repair or maintenance personnel only); and
5. what to do (e.g., contact the supervisor) if a safeguard is damaged, missing, or unable to provide adequate protection.

This kind of safety training is necessary for new operators and maintenance or setup personnel, when any new or altered safeguards are put in service, or when workers are assigned to a new machine or operation.

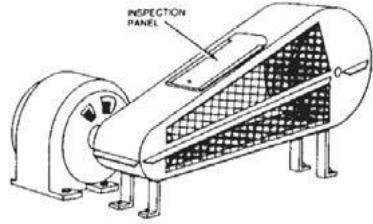
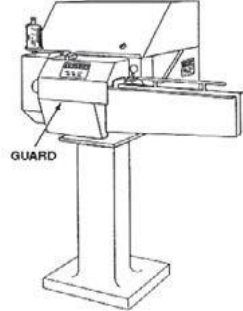
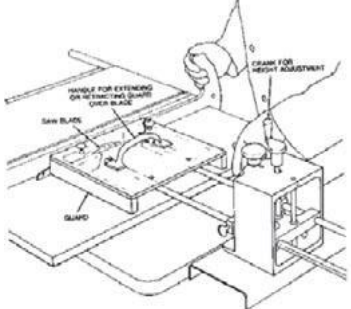
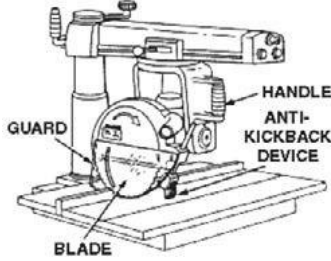
## Types of Guards

<p><b>Fixed Guard</b></p> <p>A fixed guard is a permanent part of the machine. It is not dependent upon moving parts to perform its intended function. It may be constructed of sheet metal, screen, wire cloth, bars, plastic, or any other material that is substantial enough to withstand whatever impact it may receive and to endure prolonged use. This guard is usually preferable to all other types because of its relative simplicity and permanence</p>	
<p><b>Interlocked Guard</b></p> <p>Interlocked guards automatically shut off or disengage the power when opened or removed. The machine cannot cycle or be started until the guard is back in place.</p>	
<p><b>Adjustable guards</b></p> <p>Adjustable guards are useful because they allow flexibility in accommodating various sizes of materials to be cut, shaped or formed.</p>	
<p><b>Self-Adjustable Guards</b></p> <p>The openings of self-adjustable guards are determined by the movement of the stock. As the operator moves the stock into the danger area, the guard is pushed away, providing an opening that is only large enough to admit the stock. After the stock is removed, the guard returns to the rest position.</p>	

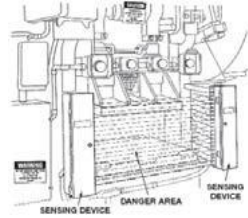
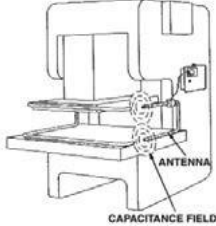
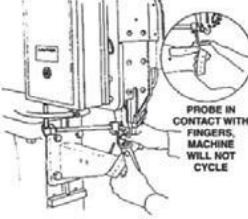
## Presence-Sensing Devices

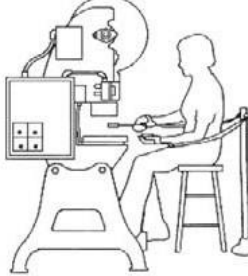
<p><b>Photoelectrical (optical) sensing device</b></p> <p>Uses a system of light sources and controls that can interrupt the machine's operating cycle. If the field of light is broken, the machine stops and will not cycle. This device should be used only on machines that can be stopped before the worker can reach the danger area.</p>	
<p><b>Radio-frequency (capacitance) sensing device</b></p> <p>Uses a radio beam that is part of the machine control circuit. When the capacitance field is broken, the machine will stop or will not activate. Like the photoelectric device, this device should only be used on machines that can be stopped before the worker can reach the danger area. This requires a friction clutch or other reliable means for stopping.</p>	
<p><b>Electromechanical sensing device</b></p> <p>A probe or contact bar that descends to a predetermined distance when the operator initiates the machine cycle. If there is an obstruction preventing it from descending its full predetermined distance, the control unit does not actuate the machine cycle.</p>	
<p><b>Pullback devices</b></p> <p>Utilize a series of cables attached to the operator's hands, wrists, and/or arms. This type of device is primarily used on machines with a stroking action. When the slide or ram is up, the operator is allowed access to the point of operation. When the slide or ram begins to descend, a mechanical linkage automatically ensures withdrawal of the hands from the point of operation.</p>	
<p><b>Restraint device</b></p> <p>Utilizes cables or straps that are attached to the operator's hands and to a fixed point. The cables or straps should be adjusted to let the operator's hands travel within a predetermined safe area.</p>	

## Safety Trip Controls

Safety trip controls provide a quick means for deactivating the machine in an emergency situation.

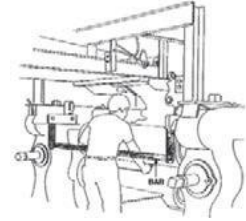
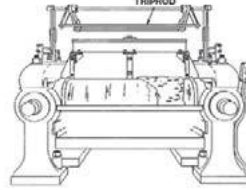
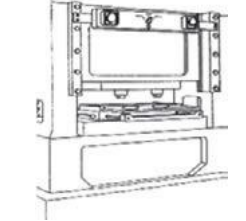
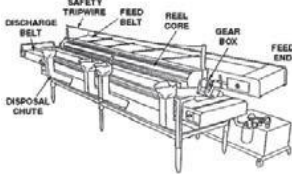
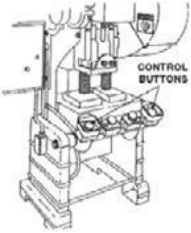
<p><b>Body Bar</b></p> <p>A pressure-sensitive body bar, when depressed, will deactivate the machine. If the operator or anyone trips, loses balance, or is drawn into the machine, applying pressure to the bar will stop the operation.</p>	
<p><b>Tripod</b></p> <p>A safety tripod, when pressed by the operator's hand, deactivates the machine. Because it has to be actuated by the operator during emergency situations, proper position is critical.</p>	
<p><b>Tripwire</b></p> <p>Safety tripwire cables are located around the perimeter of or near the danger area. The operator should be able to reach the cable with either hand to stop the machine.</p>	
<p><b>Two-hand control</b></p> <p>Two-hand control requires constant, concurrent pressure by the operator to activate the machine. This kind of control requires a part-revolution clutch, brake, and a brake monitor if used on a power press. With this type of device, the operator's hands are required to remain at a safe location (on the control buttons) and at a safe distance from the danger area while the machine completes its closing cycle.</p>	
<p><b>Two-hand trip</b></p> <p>A two-hand trip requires concurrent application of both of the operator's control buttons to activate the machine cycle, after which the hands are free. This device is usually used with machines equipped with full-revolution clutches. The trips should be placed far enough from the point of operation to make it impossible for the operator to move his or her hands from the trip buttons or handles into the point of operation before the first half of the cycle is completed. The operator's hands are kept far enough away to prevent them from being accidentally placed in the danger area before the slide, ram, or blade reaches the full "down" position.</p>	

## GATES

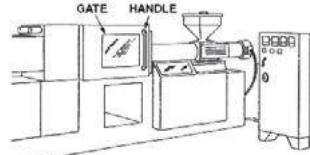
<p><b>Gates</b></p> <p>Movable barriers that protect the operator at the point of operation before the machine cycle text can be started. Gates are, in many instances, designed to be operated with each machine cycle.</p>	
--	---

## Advantages and Disadvantages

Guard Type	Application	Advantages	Disadvantages
<b>Fixed</b>	Provides a barrier.	<ul style="list-style-type: none"> <li>Can be constructed to suit many specific applications. In-plant construction is often possible.</li> <li>Can provide maximum protection.</li> <li>Usually requires minimum maintenance.</li> <li>Can be suitable to high production, repetitive operations.</li> </ul>	<ul style="list-style-type: none"> <li>May interfere with visibility. Can be limited to specific operations.</li> <li>Machine adjustment and repair often require its removal, thereby necessitating other means of protection for maintenance personnel.</li> </ul>
<b>Interlock</b>	Shuts off or disengages power and prevents starting of machine when guard is open; should require the machine to be stopped before the worker can reach into the danger area.	<ul style="list-style-type: none"> <li>Can provide maximum protection.</li> <li>Allows access to machine for removing jams without time-consuming removal of fixed guards.</li> </ul>	<ul style="list-style-type: none"> <li>Requires careful adjustment and maintenance.</li> <li>May be easy to disengage jams.</li> </ul>
<b>Adjustable</b>	Provides a barrier that may be adjusted to facilitate a variety of production operations.	<ul style="list-style-type: none"> <li>Can be constructed to suit many specific applications.</li> <li>Can be adjusted to admit varying sizes of stock.</li> </ul>	<ul style="list-style-type: none"> <li>Hands may enter danger area; protection may not be complete at all times.</li> <li>May require frequent maintenance and/or adjustment.</li> <li>The guard may be made ineffective by the operator.</li> <li>May interfere with visibility.</li> </ul>
<b>Self-adjusting</b>	Provides a barrier that moves according to the size of the stock entering the danger area.	<ul style="list-style-type: none"> <li>Off-the-shelf guards are often commercially available.</li> </ul>	<ul style="list-style-type: none"> <li>Does not always provide maximum protection.</li> <li>May interfere with visibility.</li> <li>May require frequent maintenance and adjustment.</li> </ul>
<b>Fixed Photo-electric</b>	Machine will not start cycling when the light field is interrupted. When the light field is broken by any part of the operator's body during the cycling process, immediate machine braking is activated by a barrier.	<ul style="list-style-type: none"> <li>Can allow freer movement for operator.</li> <li>Simplicity of use.</li> <li>Used by multiple operators.</li> <li>Provide passerby protection.</li> <li>No adjustment required.</li> </ul>	<ul style="list-style-type: none"> <li>May interfere with visibility.</li> <li>Does not protect against mechanical failure.</li> <li>Limited to machines that can be stopped.</li> </ul>
<b>Electro-mechanical</b>	Contact bar or probe travels a predetermined distance between operator and danger area. Interruption of this movement prevents machine cycle starting.	<ul style="list-style-type: none"> <li>Can allow access at the point of operation.</li> </ul>	<ul style="list-style-type: none"> <li>Contact bar or probe should be properly adjusted for each application; this adjustment should be maintained properly.</li> </ul>

Guard Type	Application	Advantages	Disadvantages
<b>Pullback</b>	As the machine begins to cycle, the operator's hands are pulled out of the danger area.	<ul style="list-style-type: none"> <li>Eliminates need for auxiliary barriers or other interference at the danger area.</li> </ul>	<ul style="list-style-type: none"> <li>Limits movement of operator.</li> <li>May obstruct workspace around operator.</li> </ul>
<b>Restraint (holdback)</b>	Prevents the operator from reaching into the danger area.	<ul style="list-style-type: none"> <li>Little risk of mechanical failure.</li> </ul>	<ul style="list-style-type: none"> <li>Adjustments should be made for specific operations and for each individual.</li> <li>Requires frequent inspections and regular maintenance.</li> <li>Requires close supervision of the operators' use of the equipment.</li> <li>Limits movement of operator.</li> <li>May obstruct workspace.</li> <li>Adjustments should be made for specific operations and each individual.</li> </ul>
<b>Safety trip controls:</b> <ul style="list-style-type: none"> <li>Pressure-sensitive body bar</li> <li>Safety triprod</li> <li>Safety tripwire</li> </ul>	Stops machine when tripped.	<ul style="list-style-type: none"> <li>Simplicity of use.</li> </ul>	<ul style="list-style-type: none"> <li>All controls should be manually activated.</li> <li>May be difficult to activate controls because of their location.</li> <li>Only protects the operator.</li> <li>May require special fixtures to hold work.</li> <li>May require a machine brake.</li> </ul>
<b>Two-hand control</b>	Concurrent use of both hands is required, preventing the operator from entering the danger area.	<ul style="list-style-type: none"> <li>Operator's hands are at a pre-determined location.</li> <li>Operator's hands are free to pick up a new part after first half of cycle is completed.</li> </ul>	<ul style="list-style-type: none"> <li>Requires a partial cycle machine with a brake.</li> <li>Some two-handed controls can be rendered unsafe by holding with arm or blocking, thereby permitting one-hand operation.</li> <li>Protects only the operator.</li> </ul>
<b>Two-hand trip</b>	Concurrent use of two hands on separate controls prevents hands from being in danger area when machine cycle starts.	<ul style="list-style-type: none"> <li>Operator's hands are away from danger area.</li> <li>Can be adapted to multiple operations.</li> <li>No obstruction to hand feeding.</li> <li>Does not require adjustment for each operation.</li> </ul>	<ul style="list-style-type: none"> <li>Operator may try to reach into danger area after tripping machine.</li> <li>Some trips can be rendered unsafe by holding with arm or blocking, thereby permitting one-hand operation.</li> <li>Protects only the operator.</li> <li>May require special fixtures.</li> </ul>
<b>Gate</b>	Provides a barrier between danger area and operator or other personnel.	<ul style="list-style-type: none"> <li>Can prevent reaching into or walking into the danger area.</li> </ul>	<ul style="list-style-type: none"> <li>May require frequent inspection and regular maintenance.</li> <li>May interfere with operator's ability to see the</li> </ul>

### Safe Distance Requirements for Guard Design

Largest Allowable Guard Opening—centimeters (inches)	
If the distance (A) from hazard to the guard is:	Then the opening (B) in the guard or between the table and the guard cannot be greater than:
1.27 – 3.81 cm (1/2 to 1 1/2 in)	0.64 cm (1/4 in)
3.81 – 6.35 cm (1 1/2 to 2 1/2 in)	0.95 cm (3/8 in)
6.35 – 8.89 cm (2 1/2 to 3 1/2 in)	1.27 cm (1/2 in)
8.89 – 13.97 cm (3 1/2 to 5 1/2 in)	1.59 cm (5/8 in)
13.97 – 16.51 cm (5 1/2 to 6 1/2 in)	1.91 cm (3/4 in)
16.51 – 19.05 cm (6 1/2 to 7 1/2 in)	2.22 cm (7/8 in)
19.05 – 31.75 cm (7 1/2 to 12 1/2 in)	3.18 cm (1 1/4 in)
31.75 – 39.37 cm (12 1/2 to 15 1/2 in)	3.81 cm (1 1/2 in)
39.37 – 44.45 cm (15 1/2 to 17 1/2 in)	4.76 cm (1 7/8 in)
44.45 – 80.01 cm (17 1/2 to 31 1/2 in)	5.40 cm (2 1/8 in)
Over 80.01 cm (Over 31 1/2 in)	15.24 cm (6 in)

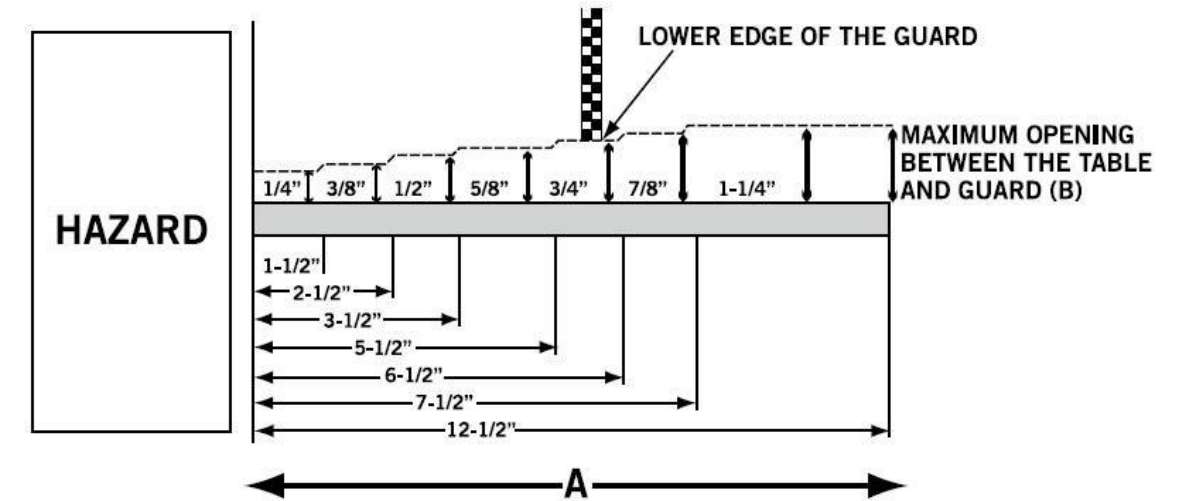

Diagram shows distance in inches.

### Machine Guarding Checklist

Answers to the following questions should help the interested reader determine the safeguarding needs of his or her own workplace, by drawing attention to hazardous conditions or practices requiring correction.

Requirements		Meet requirement?	
<b>Safeguards</b>	Do the safeguards provided meet the minimum SES requirements?	<input type="checkbox"/> Yes	<input type="checkbox"/> No
	Do the safeguards prevent workers' hands, arms, and other body parts from making contact with dangerous moving parts?	<input type="checkbox"/> Yes	<input type="checkbox"/> No
	Are the safeguards firmly secured and not easily removable?	<input type="checkbox"/> Yes	<input type="checkbox"/> No
	Do the safeguards ensure that no object will fall into the moving parts?	<input type="checkbox"/> Yes	<input type="checkbox"/> No
	Do the safeguards permit safe, comfortable, and relatively easy operation of the machine?	<input type="checkbox"/> Yes	<input type="checkbox"/> No
	Can the machine be oiled without removing the safeguard?	<input type="checkbox"/> Yes	<input type="checkbox"/> No
	Is there a system for shutting down the machinery before safeguards are removed?	<input type="checkbox"/> Yes	<input type="checkbox"/> No
	Can the existing safeguards be improved?	<input type="checkbox"/> Yes	<input type="checkbox"/> No
<b>Mechanical Hazards</b>	<b>The point of operation:</b>		
	Is there a point-of-operation safeguard provided for the machine?	<input type="checkbox"/> Yes	<input type="checkbox"/> No
	Does it keep the operator's hands, fingers, body out of the danger area?	<input type="checkbox"/> Yes	<input type="checkbox"/> No
	Is there evidence that the safeguards have been tampered with or removed?	<input type="checkbox"/> Yes	<input type="checkbox"/> No
	Could you suggest a more practical, effective safeguard?	<input type="checkbox"/> Yes	<input type="checkbox"/> No
	Could changes be made on the machine to eliminate the point-of-operation hazard entirely?	<input type="checkbox"/> Yes	<input type="checkbox"/> No
	<b>Power transmission apparatus:</b>		
	Are there any unguarded gears, sprockets, pulleys, or flywheels on the apparatus?	<input type="checkbox"/> Yes	<input type="checkbox"/> No
	Are there any exposed belts or chain drives?	<input type="checkbox"/> Yes	<input type="checkbox"/> No
	Are there any exposed set screws, keyways, collars, etc.?	<input type="checkbox"/> Yes	<input type="checkbox"/> No
	Are starting and stopping controls within easy reach of the operator?	<input type="checkbox"/> Yes	<input type="checkbox"/> No
	If there is more than one operator, are separate controls provided?	<input type="checkbox"/> Yes	<input type="checkbox"/> No
	<b>Other moving parts:</b>		
	Are safeguards provided for all hazardous moving parts of the machine, including auxiliary parts?	<input type="checkbox"/> Yes	<input type="checkbox"/> No
<b>Non-mechanical hazards:</b>			
Have special guards, enclosures, or personal protective equipment been provided, where necessary, to protect workers from exposure to harmful substances used in machine operation?	<input type="checkbox"/> Yes	<input type="checkbox"/> No	
<b>Electric Hazards</b>	Is the machine installed in accordance with SES and applicable local requirements?	<input type="checkbox"/> Yes	<input type="checkbox"/> No
	Are there loose conduit fittings?	<input type="checkbox"/> Yes	<input type="checkbox"/> No
	Is the machine properly grounded?	<input type="checkbox"/> Yes	<input type="checkbox"/> No
	Is the power supply correctly fused and protected?	<input type="checkbox"/> Yes	<input type="checkbox"/> No
	Do workers occasionally receive minor shocks while operating any of the machines?	<input type="checkbox"/> Yes	<input type="checkbox"/> No

### Machine Guarding Checklist – continued

Requirements		Meet requirement?	
<b>Training</b>	Do operators and maintenance workers have the necessary training in how to use the safeguards and why?	<input type="checkbox"/> Yes	<input type="checkbox"/> No
	Have operators and maintenance workers been trained in where the safeguards are located, how they provide protection, and what hazards they protect against?	<input type="checkbox"/> Yes	<input type="checkbox"/> No
	Have operators and maintenance workers been trained in how and under what circumstances guards can be removed?	<input type="checkbox"/> Yes	<input type="checkbox"/> No
	Have workers been trained in the procedures to follow if they notice guards that are damaged, missing, or inadequate?	<input type="checkbox"/> Yes	<input type="checkbox"/> No
	<b>Protective Equipment and Proper Clothing</b>	Is protective equipment required?	<input type="checkbox"/> Yes
	If protective equipment is required, is it appropriate for the job, in good condition, kept clean and sanitary, and stored carefully when not in use?	<input type="checkbox"/> Yes	<input type="checkbox"/> No
	Is the operator dressed safely for the job (i.e., no loose-fitting clothing or jewelry)?	<input type="checkbox"/> Yes	<input type="checkbox"/> No
<b>Machinery Maintenance and Repair</b>	Have maintenance workers received up-to-date instruction on the machines they service?	<input type="checkbox"/> Yes	<input type="checkbox"/> No
	Do maintenance workers lock out the machine from its power sources before beginning repairs?	<input type="checkbox"/> Yes	<input type="checkbox"/> No
	Where several maintenance workers work on the same machine, are multiple lock-out devices used?	<input type="checkbox"/> Yes	<input type="checkbox"/> No

**Noise Management  
US OSHA Permissible Exposure  
Levels**

Duration per day, hours	Sound level dBA slow response
8	90
6	92
4	95
3	97
2	100
1½	102
1	105
½	110
¼ or less	115

**CHEMICAL MANAGEMENT**

**General Guidelines for Chemical Storage & Incompatible Chemicals**

The chemical storage guidelines on the tables that follow do not cover all possible chemical incompatibilities. (A more comprehensive table is found at: [https://www.ehs.harvard.edu/sites/ehs.harvard.edu/files/chemical\\_waste\\_chemical\\_compatibility\\_chart.pdf](https://www.ehs.harvard.edu/sites/ehs.harvard.edu/files/chemical_waste_chemical_compatibility_chart.pdf). It is important for factories to thoroughly research the properties of the chemicals they are using, including reviewing the chemical incompatibility section of the Material Safety Data Sheets.

Chemical Class	Storage Guidelines
<b>Acids</b>	<ul style="list-style-type: none"> <li>• Store away from reactive metals such as potassium, sodium, magnesium.</li> <li>• Store oxidizing acids away from organic acids, flammable and combustible materials.</li> <li>• Store acids away from chemicals which could generate toxic or flammable gases upon contact.</li> <li>• Store acids away from bases.</li> </ul>
<b>Bases</b>	<ul style="list-style-type: none"> <li>• Store bases away from acids, metals, explosives, organic peroxides and easily ignitable materials.</li> </ul>
<b>Solvents (Flammable and Halogenated Solvents)</b>	<ul style="list-style-type: none"> <li>• Store in approved safety cans or cabinets.</li> <li>• Store away from oxidizing acids and other oxidizers.</li> <li>• Keep away from heat sources, including sparks and open flames.</li> </ul>
<b>Oxidizers</b>	<ul style="list-style-type: none"> <li>• Store in a cool, dry place.</li> <li>• Store away from combustible and flammable materials.</li> <li>• Store away from reducing agents such as zinc, alkali metals, and formic acid.</li> </ul>
<b>Cyanides</b>	<ul style="list-style-type: none"> <li>• Store away from acids and oxidizers.</li> </ul>
<b>Water Reactive Chemicals</b>	<ul style="list-style-type: none"> <li>• Store in a cool, dry place away from any water source.</li> <li>• D Class fire extinguisher must be nearby.</li> </ul>



**Table 1**

This table shows general recommendations for the separation or segregation of different classes of dangerous substances.

		Class	2	3	4	5	6	8					
<b>Compressed Gases</b>													
2.1	Flammable		KEEP APART	SEGREGATE FROM or KEEP APART	SEGREGATE FROM	SEGREGATE FROM	SEGREGATE FROM	SEGREGATE FROM	SEGREGATE FROM	ISOLATE	KEEP APART	KEEP APART	KEEP APART
2.2	Non-flammable Non-toxic		KEEP APART	KEEP APART	KEEP APART	SEPARATION MAY NOT BE NECESSARY	SEGREGATE FROM	SEPARATION MAY NOT BE NECESSARY	SEGREGATE FROM	SEGREGATE FROM	SEGREGATE FROM	KEEP APART	KEEP APART
2.3	Toxic		SEGREGATE FROM or KEEP APART	KEEP APART	SEGREGATE FROM	KEEP APART	SEGREGATE FROM	KEEP APART	SEGREGATE FROM	SEGREGATE FROM	SEGREGATE FROM	KEEP APART	KEEP APART
<b>Flammable Liquids</b>													
3			SEGREGATE FROM	KEEP APART	SEGREGATE FROM	KEEP APART	SEGREGATE FROM	SEGREGATE FROM	SEGREGATE FROM	ISOLATE	KEEP APART	KEEP APART	KEEP APART
<b>Flammable Solids</b>													
4.1	Readily Combustible		SEGREGATE FROM	SEPARATION MAY NOT BE NECESSARY	KEEP APART	KEEP APART	KEEP APART	SEGREGATE FROM	SEGREGATE FROM	SEGREGATE FROM	KEEP APART	KEEP APART	SEPARATION MAY NOT BE NECESSARY
4.2	Spontaneously Combustible		SEGREGATE FROM	SEGREGATE FROM	SEGREGATE FROM	SEGREGATE FROM	KEEP APART	KEEP APART	SEGREGATE FROM	ISOLATE	KEEP APART	KEEP APART	KEEP APART
4.3	Dangerous when wet		SEGREGATE FROM	SEPARATION MAY NOT BE NECESSARY	KEEP APART	SEGREGATE FROM	SEGREGATE FROM	KEEP APART	KEEP APART	SEGREGATE FROM	SEPARATION MAY NOT BE NECESSARY	SEPARATION MAY NOT BE NECESSARY	SEPARATION MAY NOT BE NECESSARY
<b>Oxidizing Substances</b>													
5.1	Oxidizing Substances		SEGREGATE FROM	SEPARATION MAY NOT BE NECESSARY	SEPARATION MAY NOT BE NECESSARY	SEGREGATE FROM	SEGREGATE FROM	SEGREGATE FROM	KEEP APART	SEGREGATE FROM	KEEP APART	KEEP APART	KEEP APART
5.2	Organic Peroxides		ISOLATE	SEGREGATE FROM	SEGREGATE FROM	ISOLATE	SEGREGATE FROM	SEGREGATE FROM	SEGREGATE FROM	SEGREGATE FROM	KEEP APART	KEEP APART	KEEP APART
<b>Toxic Substances</b>													
6			KEEP APART	SEPARATION MAY NOT BE NECESSARY	SEPARATION MAY NOT BE NECESSARY	KEEP APART	KEEP APART	KEEP APART	SEPARATION MAY NOT BE NECESSARY	KEEP APART	KEEP APART	KEEP APART	SEPARATION MAY NOT BE NECESSARY

		Class	2	3	4	5	6	8					
		<b>Corrosive Substances</b>											
		KEEP APART	KEEP APART	KEEP APART	KEEP APART	SEPARATION MAY NOT BE NECESSARY	KEEP APART	SEPARATION MAY NOT BE NECESSARY	KEEP APART	KEEP APART	SEPARATION MAY NOT BE NECESSARY	KEEP APART	KEEP APART

**Compatibility Chart Terminology:**

**KEEP APART:** Keep at minimum 3m apart.

**SEGREGATE:** Keep in separate compartments of the same store, separated by at least a firewall or in a separate building.

**ISOLATE:** Keep in separate building or isolate within a cabinet designed for this purpose.

**EXTREME TEMPERATURES**

Item	Meets requirement?	Corrective Action
Thermometers: properly working?	<input type="checkbox"/> Yes <input type="checkbox"/> No	
Temperature control equipment: properly working? (E.g., thermostats, heaters, fans, air conditioners)		
Adequate water supply for worker population in extremely hot conditions?		
Rest breaks are frequent enough and in suitable conditions (located in warm area if temperature conditions are extremely cold, in shaded or cooler area if temperature conditions are extremely hot)?		
The right kinds of personal protective equipment are provided for work in extremely cold conditions or around hot equipment?		

**Heat Stress: General Workplace Review**

**Note:** Listed below are sample questions that the Program Evaluator may wish to consider when investigating heat stress in the workplace.

**Workplace Description**

- |   |                                       |  |
|---|---------------------------------------|--|
| 1. Type of business                                   | • Is the heat steady or intermittent? | • Is potable water available?                                      |
| 2. Heat-producing equipment or processes used         | • Number of employees exposed?        | • Are supervisors trained to detect/evaluate heat-stress symptoms? |
| 3. Previous history (if any) of heat-related problems | • For how many hours per day?         |  |
| 4. At "hot" spots:                                    |                                       |  |

**Are Exposures Typical for a Workplace in This Industry?**

- |  |                                       |  |
|--|---------------------------------------|--|
| 1. Weather at Time of Review   | 3. Heat-Reducing Engineering Controls | • Fans in place?                                       |
| • Temperature  | • Ventilation in place?               | • Fans operating?                                      |
| • Humidity   | • Ventilation operating?              | • Shields or insulation between sources and employees? |
| • Air velocity   | • Air conditioning in place?          | • Are reflective faces of shields clean?               |
| 2. Is day typical of recent weather conditions? (Get information from the Weather Bureau.) | • Air conditioning operating?         |  |

**Work Practices to Detect, Evaluate, and Prevent or Reduce Heat Stress**

- |  |   |   |
|--|---|---|
| 1. Training program?   | 8. Personal Protective Equipment  | • Provision for rapid cool-down?  |
| • Content?   | • Reflective clothing in use?   | • Procedures for getting medical attention?                                       |
| • Where given?   | • Ice and/or water-cooled garments in use?                                    | • Transportation to medical facilities readily available for heat stroke victims? |
| • For whom?  | • Wetted undergarments (used with reflective or impermeable clothing) in use? | 10. Medical Screening and Surveillance Program                                    |
| 2. Liquid replacement program?   | • Circulating air systems in use?   | • Content?  |
| 3. Acclimatization program?  |   | • Who manages program?  |
| 4. Work/rest schedule?   | 9. First Aid Program  |   |
| 5. Scheduling of work (during cooler parts of shift, cleaning and maintenance during shut-downs, etc.) | • Trained personnel?  |   |
| 6. Cool rest areas (including shelter at outdoor work sites)?  |   |   |
| 7. Heat monitoring program?  |   |   |

**Background Information**

**Health Effects:**

Serious illness, including cancer, can result from exposure to asbestos fibers. This depends upon many factors, including the type of asbestos, how much asbestos-containing material an individual is exposed to, how long he/she is exposed, and whether or not an exposed individual smokes cigarettes<sup>1</sup>.

**Use of Asbestos in Buildings:**

Since its earliest use, asbestos has been increasingly used for insulation coating and fireproofing and has been added to construction materials for a variety of purposes. Asbestos can be found in many places throughout a building. Asbestos containing building materials may include the

following:

- Thermal System Insulation
  1. insulated boiler
  2. steam pipe
  3. ducts
  4. hot-water pipes
  5. exhaust system
  6. high-temperature gaskets and valve insulation
- Surfacing Materials
  1. sprayed or troweled-on surfacing materials on ceilings, walls, and acoustic and decorative insulation
- 2. textured paint and coatings
- 3. plaster and stucco
- 4. taping and joint compound
- 5. fireproof drywall
- 6. fireproof drapes and curtains
- Miscellaneous Materials
  1. roofing felts and shingles
  2. exterior siding shingles
  3. sprayed-on fireproofing on metal beams and columns
  4. resilient asphalt
  5. vinyl flooring, mastics, and seal

**Friable vs. non-Friable Asbestos:**

A friable asbestos product is one that you can crumble, pulverize, or otherwise cause to release dust simply by applying hand pressure. A non-friable asbestos material will not release dust or crumble by hand pressure. Friable materials are more likely to release asbestos fibers into the air and, therefore, are considered more hazardous to worker health. The following lists describe materials that are usually friable, sometimes friable, and rarely friable.

**Usually Friable**

- sprayed-on acoustic insulation
- plaster and textured paints
- sprayed-on structural fireproofing

**Sometimes Friable**

- pipe insulation
- boiler insulation
- roofing felt
- duct wrap

**Rarely Friable**

- transit ducts
- transit boards
- vinyl tile and mastics
- asphalt
- shingles

Products listed in the “Usually” and “Sometimes” friable categories are always treated as being friable. Products listed as “Rarely” friable can become friable over time if disturbed.

The specific amount or percent of asbestos in a product is not relevant. If the product has more than 1 percent asbestos, treat the product as asbestos-containing material and disregard the specific percent asbestos. The friability of the material will be a significant factor in how a qualified contractor decides to manage it.

---

1 Cigarette smoking increases the likelihood of an individual developing a type of asbestos-related disease (mesothelioma).

# Annex B: Health Guidelines

## HEALTH TRAINING

### Appendix 1: Monthly Report of Serious Illnesses in the Factory

Name of the Factory: \_\_\_\_\_ Month of Reporting: \_\_\_\_\_

Details of Hospital Admissions \_\_\_\_\_

Name of worker	ID NO	Reason for Admission	Admitted at	Follow Up HCP/ Doctor	Diagnosis	Cost of Treatment		
						Total	Patient	Company

A consolidation of these monthly reports in each factory will help identify common health problems that require hospital admission.

## Appendix 2: Summary of the Most Common Cases Reported to Factory Health Care Professional (HCP)

Name of the Factory: \_\_\_\_\_ Reporting Period: \_\_\_\_\_

No. of working days in the factory: \_\_\_\_\_

Name of HCP: \_\_\_\_\_ No. of workers treated by HCP: \_\_\_\_\_

List 10 most common causes of illness reported to HCP, and adjust this list at least quarterly:

Disease/Complaint	Body pain	Headache	Fever	---	---	---	---	---	---	---
No. of cases										

**Appendix 3: Report of Incidents on Factory Floor: (e.g. needle injury, trimmer injury)**

Name of the Factory: \_\_\_\_\_ Reporting Period: \_\_\_\_\_

No. of working days in the factory: \_\_\_\_\_

Name of HCP: \_\_\_\_\_ No. of workers treated by HCP: \_\_\_\_\_

Name of worker	ID No	Nature of Emergency	Time	Day/Date	Action taken	Occupational/ Others

A consolidation of these reports will give the factory an idea of the most common emergencies (not only injuries) that are seen on the shop floor

**Appendix 4: Causes for Sick Leave on the Factory Floor:**

Name of the Factory: \_\_\_\_\_ Reporting Period: \_\_\_\_\_

No. of working days in the factory: \_\_\_\_\_

Name of HR Executive: \_\_\_\_\_

Name of worker	ID No	Department	Reason for Sick Leave	No. of Days of Leave	Notes

A consolidation of these reports will give the factory an idea of the most common reasons for sick leave among the workers.

**FIRST  
AID**

**First Aid Logbook**

Sl. No	Worker's Name	ID No	Department	Job Title	Date and Time of Injury	Injury Description	First Aid provided

**Details of Significant Injuries**

Particulars	Details
Name	
Age	
Token Number	
Batch/Section	
Date and Time of accident	
Type of Injury	
Precise anatomical organ that was injured.	
Operation/Task being performed at the time of accident	
Details of how the accident occurred	
Was the accident avoidable? If yes, how?	
Was the injured person wearing protective / safety equipment at the time of accident?	
Was the operator fully aware of the "dos and don'ts" of the machine in use?	
Was the operator trained to use the machine or gadget?	
Was the accident due to unsafe condition of the machine?	
Any suggestion to avoid such type of accident in future?	
Treatment given:	

### A quick guide to dealing with common injuries/illnesses in the factory

- The factory is recommended to have at least the items listed in [this table](#) as part of its First Aid Box. Additional items will be available at the first aid room/ ambulance room/ medical center.
- First aid responders should realize that commonly available materials can provide useful first aid: clean cloth and clean water may be available very close to the place where the accident has happened until the First Aid Box is brought to the scene. It is important to remember that one's own hands must be clean before administering first aid.
- In all cases where first aid has been provided, be sure promptly to take the worker to a medical professional to ensure that all that needs to be done has been done.
- **Needle injuries:** Make sure that no part of the needle is stuck in the finger. Promptly contact the health care professional. If it is suspected that a bit of the needle is still under the skin/ bleeding part, be sure too to inform the health care professional.
- If the needle is intact, wash the injured finger with the antiseptic liquid that is available in the First Aid Box. Then take the sterile pad and place it on the point where there is bleeding and apply pressure.
- 
- **Trimmer cuts:** In these cases, the bleeding may be very minimal or very profuse depending on the amount of skin that has been cut. In both cases, wash the area with the antiseptic liquid. Then apply pressure using the sterile pad. The bleeding should stop, if continuous pressure is applied for about 1-2 minutes. As with all instances where first aid is administered, promptly contact the health care professional
- **Deep wounds:** Such wounds may occur, for example, if a worker falls on a sharp object. If the first aid responder feels that the wound is deep, wash the wound with clean water or with antiseptic liquid. Apply a sterile pad that is big enough to cover all edges of the wound and promptly contact the health care professional. DO NOT try to remove any dirt that appears to be stuck to the open wound. That is the job of a medical professional.
- **Fractures and Dislocations:** These are rare occurrences in the garment industry. If a worker meets with an accident where there is any suspicion of a bone been broken, the first aid responder should ensure that there is no movement of the injured part. Provide support to the broken part by using some hard material (wooden ruler/scale, long cardboard piece). Use the triangular bandage to keep the part supported (in the case of fractures to the arm). Promptly contact the health care professional. Fractures and dislocations will have to be treated at a hospital.
- **Blunt injuries:** This can occur when the worker falls down or when a moving machine part hits him/her. If there is a swelling, immobilize the part and apply some cold water (or ice, if available). A painkiller tablet can be given at the first aid station. Promptly contact the health care professional.

- **Deep cut in finger:** These injuries can occur when a worker does not use protective equipment while using the mechanized knife (band-knife or straight knife). If a part of the finger is severed, DO NOT panic. Pick up the severed piece and place it in a plastic bag containing cold water (with ice if possible) and promptly contact the health care professional.
- **Eye injuries:** These can occur when some dust enters into the eye. If this occurs, take the worker to the nearest water tap/faucet and splash as much water as possible, till s/he feels relieved. If the worker still feels like there is something in his/her eye, promptly contact the health care professional.
  - In more severe cases, such as when a piece of a button (at the buttoning machine) breaks off during the buttoning operation and injures the eye, place the sterile pad gently on the eye and promptly contact the health care professional.
  - If the eye is injured by some chemical splash, move the worker to the eye-washing station. Allow as much water as possible to wash the eye.
  - In all these cases, advise the worker NOT TO rub the eye with the hands. After first aid has been given, promptly contact the health care professional.
- **Bleeding from the nose:** Hold the nose tightly and ask the worker to bend forward. Continuous tight pressure should stop the bleeding in 1-2 minutes. If the bleeding does not stop within 5 minutes or if it recurs, promptly contact the health care professional.
- **Head injury:** When a worker loses consciousness after being hit on the head (by a fall or moving machinery) appears confused or starts vomiting or has severe headache after the injury promptly contact the health care professional.
- **Burns:** This can happen in the factory when a worker comes into contact with a hot object like the steam iron or the fusing machine. Burns can also happen when workers who are handling strong chemicals come into contact with the substance. In all such cases, the first thing to do is to wash/soak the area with/in cold water. Leave the part in contact with water for some time – even 10-15 minutes. This will soothe the pain especially if they are minor burns. Promptly contact the health care professional.
- If there are blisters formed, DO NOT try to prick holes in them. In such cases and in cases where the burns have left the flesh exposed, DO NOT try to remove any fibers or dirt that is stuck to the burns wound and promptly contact the health care professional.
- **Fits:** If a worker suffers from an attack of fits while working (e.g., if the worker is a diabetic and has had insufficient insulin), lay him/her on the floor. Remove all sharp objects and hard items away from the worker. If possible, place some folded cloth or a thick piece of wood between the teeth, so that the worker does not bite his/her tongue. The attack should subside in 1-2 minutes, after which the worker will appear normal. If there are any injuries as a result of the attack, give first aid as above. Promptly contact the health care professional.
- **Fainting attacks:** Commonly, these are temporary in nature. DO NOT panic. Allow the worker to lie on the floor. Gently lift the legs, to allow for the blood to flow back to the heart. You may sprinkle some water on his/her face. Generally, the worker will “wake up” in a few seconds. Promptly contact the health care professional.



- **Unconsciousness:** These are more serious conditions when the worker could have suffered from a heart attack or some other serious problem (generally seen in older workers). Call for help from the medical professional who is in the factory. Until such time that help comes, check if the person is breathing. Trained first aid responders should know how to find the pulse – check the pulse. Trained first aid responders should start cardio-pulmonary resuscitation as soon as possible.
- **Electrocution:** Do not approach the electrocuted worker until the power switch has been turned off. Then standing as far away from the worker as possible remove him/her from the contact of the electrical wire. Promptly contact the health care professional.
- **Poisoning:** Workers may accidentally or purposely consume a poisonous liquid that is found in the factory. In such situations, the first aid respondent should try to make the worker vomit. This can be done by trying to put one’s finger into the mouth of the worker and touching the back of the mouth/throat – this will force the worker to vomit. Make sure that the poison is not a strong acid before doing this. Promptly contact the health care professional.

#### Suggested contents of a training program on first aid for garment industry

- Minor injuries – needle injuries, small cuts, superficial wounds
- Major injuries – deep wounds, major bleeding, fractures, dislocations, amputations
- Special types of injuries – eye injuries, nose bleeds, head injuries
- Burns – superficial and deep (1<sup>st</sup> degree to 3<sup>rd</sup> degree)
- Electrocution
- Poisoning
- Fits
- Unconsciousness
- Cardio-pulmonary resuscitation (CPR)
- Transport of the injured
- Topics like snake bite, dog bite, bee stings etc. can be optional, as well as dealing with fevers, diarrhea and vomiting.

## COMMUNICABLE DISEASES

### Appendix 1: Transmission of communicable diseases.

For the purposes of understanding, it is important to recognize the cycle of disease transmission.

**Source or reservoir:** Every communicable disease has a source from which it starts. The source of infection is usually a person/animal/object/substance from which the organism causing the disease (infectious agent) passes on to a human being. The reservoir is slightly different in that the organism lives and multiplies in it – it is the natural habitat of the disease-causing organism.

Taking the example of typhoid, the human being is the reservoir of the disease, and his/her feces or urine is the source from which the disease-causing organism can be transmitted to others. It is important to understand this because the disease can be prevented if we can ensure that humans do not harbor the organism.

**Modes of transmission:** Diseases can be transmitted from one person to another by a variety of modes. Some the important modes of transmission are listed here.

- Direct contact: skin-to-skin contact, as in the case of sexually transmitted diseases
- Droplet infection: projection of a spray of saliva/secretion while sneezing or coughing, as in the case of the common cold
- Contact with soil: direct exposure of an exposed/injured part of the body to soil, as in the case of tetanus
- Inoculation into the skin: by bites or injections, as in the case of rabies (dog-bite) or hepatitis B (using infected needles)
- “Vehicle borne”: drinking contaminated water, as in the case of diarrheal diseases
- “Vector borne”: by mosquitoes that carry the disease-causing organism in their body (malaria, dengue) or by flies that mechanically transmit the disease-causing organism on their body surface (diarrheal diseases)
- Airborne: through dust or “droplet nuclei,” where the disease-causing organism rests on a particle and floats in the air to reach the susceptible person.
- Fomite borne: through inanimate objects (fomites) that can harbor the disease-causing organism, like soiled clothes, towels, door handles
- Unclean hands and fingers: when poor hygiene leads to the transmission of diseases from one person to another

**Susceptible host:** This is the human being who has certain features that predispose him/her to contract the disease. These features could be something that is as direct as the lack of immunity against a particular disease (e.g. those not vaccinated against measles can get the disease if they are exposed to a person who has the illness), or it could be something indirect as in the case of poor nutrition or poor personal hygiene.

---

The link between the source/reservoir of infection, the mode of transmission and the availability of a susceptible host is called the **chain of transmission**.

**For factory management and factory health care providers, it is important to recognize this chain of transmission to enable them to keep an eye out for possible weaknesses in the**

**links that will result in the onset of a communicable disease. In the description of common communicable diseases that follow, possible problem areas will be explained to facilitate taking steps to prevent the onset or spread of diseases.**

---

## Common communicable diseases

### Acute respiratory infections (ARIs)

#### General information

- ARI is one of the most common human ailments affecting all ages.
- It is also probably the most common infection that affects factory workers
- It is a source of discomfort, disability, loss of time for adults and major mortality and morbidity in young children and the elderly.
- It can be caused by various agents, including bacteria, viruses, and other agents.
- The mode of transmission is airborne.

#### Prevention of ARI

- Improved living conditions (good ventilation, prevention of overcrowding) and better nutrition will help in preventing the disease
- Avoidance of smoking will definitely help as well.
- Good hand-washing practices: regularly wash one's hands with soap and running water, particularly before preparing and eating food and after blowing your nose
- Cough etiquette: Cover one's mouth with a handkerchief/tissue when coughing or sneezing and use the nearest waste receptacle to dispose of the tissue.
- Avoid close contact with the person suffering from ARI
- Contact the nearest medical officer as early as possible for treatment.
- Areas where overcrowding is common, such as poor ventilation, must be identified. Locally prescribed standards (described elsewhere in this guidebook) must be followed. Special attention is required in factories that provide dormitory accommodation for their employees.
- Healthcare professionals must look out for patterns in the reporting of ARIs. Are there any locations within the factory where more employees appear to be presenting with ARI? Are there any groups of workers who are suffering from the illness? Is there an increased number of cases in the community outside the factory? Could it be something more serious? (See, e.g., guidebook sections regarding Avian/Bird Flu.)

**Note** that not all cases of watery discharge from the nose or coughs and colds are infectious in nature. These features can also be seen in allergic individuals who react adversely to exposure to dust or cloth fibers or strong-smelling paints/chemicals. The healthcare professional must be capable of distinguishing between an infection and an allergy.

- Healthcare professionals must be cautious when prescribing anti-allergy drugs for cases they know are caused by dust. The use of some of these drugs can cause drowsiness and can result in poor concentration at the workplace, leading to injuries.

---

## Diarrheal diseases

### General Information

- Diarrhea is defined as the passage of three or more loose or liquid stools per day (or more frequent passage than is normal for the individual).
- Most people who die from diarrhea actually die from severe dehydration and fluid loss.
- Diarrhea is usually a symptom of an infection in the intestinal tract, which can be caused by a variety of bacterial, viral and parasitic organisms.
- Infection is spread through contaminated food or drinking water, or from person-to-person as a result of poor hygiene (feco-oral transmission).

### Prevention of diarrheal diseases

- Access to safe drinking-water both at home and in the factory will help in the prevention of diarrheal diseases, as will the actions listed below. The locally prescribed standards for the provision of drinking water (described elsewhere in this guidebook) must be followed.
- Use of improved sanitation both at home and in the factory. Care should be taken to ensure that there is an adequate number of properly maintained toilets.
- Provision of soap for hand washing. The employees must be told to use soap at home too. (A proper technique of handwashing is important as well; there are various resources on the internet which have pictorial descriptions of the ideal method).
- Good personal and food hygiene. This includes washing hands after urination and defecation, before and after eating, and before cooking.
- Rotavirus vaccination, where available.
- Exclusive breastfeeding for the first six months of life. Provisions must be made to allow nursing mothers to feed their babies at regular intervals.

### Key measures to treat diarrhea:

- The most important step in treating diarrhea is rehydration with oral rehydration salts (ORS) solution. Adequate quantities of this must be made available in the factory clinic. ORS, which is a mixture of clean water, salt and sugar, can also be prepared at home.
- Patients must be given nutrient-rich foods to aid in the recovery.
- Consulting a health professional, particularly for management of diarrhea that lasts more than 5 days or when there is blood in stool or if there are signs of dehydration.
- Special precautions will have to be taken in countries where cholera is common (e.g., Bangladesh, Haiti).

---

## Skin Infections

### General information

- Skin infections in humans can be caused by bacteria, virus, mites, fungus etc. Of these, fungal infections are probably the most common.
- Mode of transmission is usually through direct contact (skin to skin). However, clothes that are not washed after use can also harbor infectious agents.

### Prevention of fungal infections

- Good personal hygiene, including regular baths and the use of clean clothes, are important ways in which skin infections can be prevented, as are the actions listed below.
- Follow good hand washing, laundering and keeping areas clean.
- If one person gets an infection, close contacts (people living in the same household or those in close physical contact) should be inspected for signs of infection.
- Employees must avoid the sharing of towels, combs and other personal items.
- Fungal infection of the feet can be prevented by washing the feet daily, drying them well, and wearing clean socks.
- Use dry, clean clothes every day and avoiding tight clothing.
- Particular attention should be given in areas of the factory where water logging is common (e.g., washing areas). The employees in these zones should be provided with wellingtons and appropriate gloves to avoid continuous exposure to water and to keep the limbs dry.
- Factories that provide dormitories for the employees must ensure that adequate areas are provided for the drying of washed clothes.

### Prevention of scabies

- This infestation can be particularly common in dormitories. It is caused by small mites.
- The biggest threat is that even if one person presents with the illness, it is highly likely that others in the same household or dormitory will contract the disease.
- Thus, it is important to treat all the members of the affected household/dormitory simultaneously, irrespective of their disease status.
- Intervention of a health care professional who has experience with scabidical medication.
- Ensure that the mattresses and pillows (and bed linen used by the employees) are cleaned and dried on a regular basis.

---

## Reproductive tract infections (RTIs)

### General information

- Can be caused by bacteria, virus, fungi and other parasites.
- Mode of transmission is generally by sexual contact.
- Most commonly seen among individuals in the age group 20-29 years
- Symptoms usually include discharge from urethra/ vagina, pain/swelling/ulcer in the groin.

### Prevention of RTIs

- This is an example of a disease where the factory management's (and health care professionals') knowledge about the local situation is important. If high risk behavior is common among the population in the region, health education programs that target the "at-risk" population must be implemented.
- Factories can also invest in condom vending machines.
- The general advice given to populations at risk for RTIs include
  - Avoid unprotected sexual intercourse with an infected partner
  - Consistent and correct use of condoms during sexual intercourse
  - Limiting the number of sexual partners
  - Seek medical treatment if any symptoms are present
- It is important for the physician (factory healthcare professional) to ensure that the partner of the infected individual is treated simultaneously.

## Tuberculosis

### General Information

- Tuberculosis is a disease that primarily affects the lungs and causes symptoms that are related to the respiratory tract.
- However, it can also affect other parts of the body, such as the intestines, bones, and lymph glands, among others.
- The disease is most commonly transmitted when the lung is affected. When a person with lung tuberculosis coughs, s/he releases the tuberculosis-causing bacteria into the environment which may be inhaled by other individuals.
- Social factors have a major role to play in the occurrence of the disease. These include poverty, poor quality of life, overcrowding, poor ventilation and under-nutrition. .
- The symptoms of tuberculosis include a persistent cough lasting more than 2 weeks, sputum that is blood stained, chest pain, fever, weakness/fatigue, loss of appetite, and loss of weight.
- The diagnosis is usually confirmed by testing the sputum or by taking an x-ray of the chest.

---

## Prevention of tuberculosis

- In countries where tuberculosis is common, factory management must ensure that conditions within the factory do not predispose to its transmission. Overcrowding on the factory shop floor and poor ventilation (poor air circulation) can increase the chance of disease transmission from one person to another.
- The factory healthcare provider must look out for employees who have any of the symptoms listed above.
- All countries where the disease is common have clear protocols as to what should be done when a person is suspected to have tuberculosis. These must be reviewed.
- Any person who has cough for more than two weeks must be treated with specific antibiotics, with clear instructions to complete the course of treatment. If the person's condition does not improve, then s/he must be referred to the health system for further management.
- The treatment of tuberculosis is of long duration, extending to *at least* 6 months.
- The sputum must be checked regularly to assess whether it still contains disease-causing germs. If the germs are still present, the treatment of course must be extended.
- Even if the sputum is negative for the disease-causing germ, the treatment must be continued as doctor describes. However, if the sputum is negative and the person is feeling well enough s/he may return to work while the treatment continues
- The factory healthcare provider must follow up the cases regularly because patients tend to stop taking medication once they start feeling better.

## Malaria

### General information

- Malaria is a common mosquito-borne illness in the developing world, particularly in Southeast Asia and Sub-Saharan Africa.
- Though malaria is predominantly a rural disease, with change of land utilization and population migration it is not uncommon to see urban dwellers also getting the disease.
- Environmental factors play an important role in the breeding of mosquitoes. Pits, garden pools, irrigation channels, and the construction of roads, dams, and bridges have led to situations where the disease-transmitting mosquito breeds.
- Persons who have malaria generally have symptoms that start off with fatigue, headache and cold sensations, followed by shivering. Their temperature rises. Soon they start feeling hot and want to remove their clothes. A few hours later s/he starts sweating and the fever comes down.
- Recurrence of the disease is possible, especially when appropriate treatment has not been given or where environmental conditions encourage the breeding of the mosquito.

---

## Prevention of malaria

- The key to preventing malaria is to ensure that the environment does not encourage the breeding of mosquitoes. Factories must avoid the construction of water bodies (e.g., ornamental fountains that do not function, or standing water in pots, air conditioning units or anywhere else. The collection of water can result in mosquito breeding.
- At the household level, the employees must be asked to use all protective measures. These include insect repellents (bug sprays), insecticide-treated bed nets and other products that may be locally available.
- Employees must be educated about the symptoms and signs of the disease and asked to report to the appropriate health system whenever they have fever.
- Diagnosing the disease early and taking the complete course of treatment is of great importance.

## Dengue/Chikungunya

### General Information

- Dengue and chikungunya are diseases that are transmitted by the same mosquito.
- Knowledge of habits of this species of mosquito will help prevent its breeding and thereby the spread of these diseases.
- This is important to know because there are many environmental factors in the factory that can predispose to the breeding of this mosquito.
- The mosquito breeds in small collections of water (pots, planters, cups, etc.).
- The mosquito bites in the daytime, particularly dawn and dusk.
- Dengue fever usually starts suddenly, with the patient having intense high fever, headache, muscle and joint pains. The complications of dengue fever are more dangerous: bleeding and shock.
- Chikungunya also starts suddenly and presents with high fever, chills, headache, severe back-ache and aches/stiffness of the small joints (fingers, toes, wrists, ankles).

### Prevention of dengue/chikungunya

- The key to the prevention of these conditions is environmental hygiene.
- Factory management must ensure that there are not small collections of water in the surroundings of the factory. Pots and planters should not have standing water.
- Water coolers/air-conditioning units where water can collect should be cleaned at regular intervals (at least once a week).
- The grounds around the factory must be cleaned regularly. Improper waste disposal of the community around the factory can predispose to the collections of small quantities of water.

- When there are epidemics of dengue/chikungunya in the region, all cases of fever must be suspected to be due to these diseases.
- The treatment is essentially symptomatic: paracetamol for fever (aspirin not to be given) and plenty of fluids orally.
- Any indications of bleeding (e.g., dark patches or small spots on the skin) should be considered serious enough to admit the person to the hospital.

## Influenza (including bird flu)

### General information

- Flu (influenza) is a common viral infection.
- In recent years there has been global concern because of the discovery of a new strain of the virus that can cause influenza: the bird flu (avian flu) virus.
- Although the bird flu virus does not usually affect humans, rare cases of infections have been reported. Human infections happen when enough virus gets into a person's body through the eyes, nose or mouth.
- The virus is transmitted when a person breathes in the air that contains virus or when a person touches something that has virus on it then touches their mouth, eyes or nose.
- Person-to-person transmission has not been recorded, but the worry is that the virus can change its character (which is quite possible with any influenza virus) and begin to spread from one person to another.
- The symptoms of influenza are eye infection (conjunctivitis), fever, cough, sore throat and muscle pains. In more severe cases (bad cases of bird flu), this can progress to lung infections (pneumonia), respiratory distress and respiratory failure.

### Preventive measures

- As of now, recommendations for the prevention of the spread of bird flu are targeted principally at those who work with poultry (and possibly zoos where birds are exhibited).
- Strict use of personal protective equipment is essential while handling poultry.
- Proper hand washing practices are also important: thorough and frequent washing of the hands with soap and water.
- If any employee thinks that s/he has been exposed to the virus, s/he must watch out for symptoms like fever, cough and difficulty in breathing.
- Such a person must visit a health care provider as soon as possible. More importantly, such individuals should avoid coming to work.
- Employees who believe they have a communicable common disease should immediately contact the factory health care professional so that they can be evaluated before returning to work.

---

## Hypertension/Diabetes

### General information

- Hypertension and diabetes are considered diseases of lifestyle. For this reason, they are both dealt with under this same section, although the symptoms and signs are different, and their treatment is also different.
- While there is a significant genetic predisposition to acquire these diseases, the onset of the conditions can be postponed (or totally prevented) by following a healthy lifestyle.
- Knowing that these diseases occur in the older age group of workers is important. The factory should periodically remind employees 40 years of age or older of information (see below) regarding symptoms of and prevention of hypertension and diabetes. The symptoms of hypertension (high blood pressure, high BP) include severe headaches, fatigue and confusion, vision problems, chest pain and difficulty breathing.
- The symptoms of diabetes (high sugar) include excessive thirst, going often to the toilet to urinate, blurry vision, irritability, tingling sensation of the hands, fatigue and wounds that do not heal quickly.

### Preventing hypertension/diabetes

- The following elements of a healthy lifestyle are particularly helpful in preventing hypertension and diabetes: consumption of good quality food, avoidance of salt (for hypertension), avoidance of sugar and sugary drinks (diabetes), avoidance of foods that are rich in fats and oils; and limiting portion sizes.
- Regular exercise: at least 30 minutes of brisk walking (not counting the walking during work in the factory).
- Weight reduction for those who are overweight or obese. Complete avoidance of the use of tobacco (no cigarettes and other forms of smoking tobacco).
- The factory can encourage a system of regular medical checks for all employees with a special focus on the high-risk groups: older workers, sedentary workers, overweight/obese workers.
- For those diagnosed to be hypertensive or diabetic, opportunities must be provided for regular follow-up checks at intervals not exceeding 6 months.

---

## Musculoskeletal pains

### General information

- Musculoskeletal disorders are
- Aches and pains that affect the muscles, bones and tissues that connect these to each other (ligaments, tendons).
- Blunt injury to muscular parts, accidents, and falls leading to sprains, fractures, and dislocations can cause musculoskeletal pains. Poor posture, overuse or repetitive use of a particular limb or long-term immobilization of a part of the body can cause musculoskeletal disorders.
- Symptoms can include aches and pains of a particular region of the body or fatigue so significant that it causes sleep disturbances.

### Preventing musculoskeletal pains

- The factory healthcare provider must investigate and respond appropriately to all employee complaints of significant aches and pains of any muscular or bony part of the body. While it is always possible that the origins of these problems are outside of the workplace, the health care provider must investigate whether the workplace triggered the illness.
- A visit to the worksite is called for to assess the work environment and to assess the posture adopted by the employee at work.
- As a preventive step, employees must be encouraged to exercise regularly. This in itself is very important in preventing musculoskeletal pains.
- Relaxation techniques also have positive effects
- Pain killers may be given in severe cases.

If all these interventions do not work, then job rotation or even a change in job may be recommended.

**COVID-19 PREVENTIVE RECOMMENDATIONS FOR VENDORS**

Latest revision: April 2020

As part of Levi Strauss & Co.'s ongoing efforts to ensure workers' safety and business continuity, the objective of this document is to **share the collection of the current best practices seen in the sourcing base for Covid-19 prevention in manufacturing.**

First and foremost, we strongly urge all Levi Strauss & Co. (LS&Co.) suppliers to follow legal requirements and guidance from their local government pertaining to worker occupational health and safety. We ask that each supplier develop Emergency Response Plans (ERP) to prevent and manage any reported medical cases and offer support and advice to workers and their families while maintaining business operations.

It is LS&Co.'s expectation that our suppliers will continue to follow legal requirements and our Supplier Code of Conduct . This is particularly pertinent to the payment of worker wages and other benefits as well as maintenance of effective two-way communication with workers during this crisis.

It is a collective effort, and we are open to further learnings and insight from suppliers that we can use to strengthen these recommendations for the benefit of others.

The below list of recommendations might change and mature as the epidemic evolves and might need to be adapted to particular contexts. It should not be construed as legal advice but should serve as a good starting point for the implementation of Covid-19 preventive measures.

**1. Monitoring Covid-19 Development Within Reach of the Manufacturing Facility**

A dedicated HR or Security staff should monitor and report daily the Covid-19 risk level within the country and proximity of the production facility.

**2. Preparation of a Covid-19 Prevention Protocol**

Each vendor/manufacturing facility should prepare its own Covid-19 Prevention Protocol that is documented, endorsed by Senior Management, and shared with all employees. The protocol shall contain at least the following details:

- Actively encouraging sick employees to stay home
- Sending employees with acute respiratory illness symptoms back home immediately
- Providing information and training to employees on:
  - Cough and sneeze etiquette

- Hand hygiene
- Avoiding close contact with sick persons
- Avoiding touching one's eyes, nose, and mouth with unwashed hands
- Avoiding sharing personal items with co-workers (i.e., dishes, cups, utensils, single-use towels)
- Providing tissues, no-touch disposal trash cans and hand sanitizer for use by employees
- Performing routine environmental cleaning of shared workplace equipment and furniture (disinfection beyond regular cleaning is not recommended)
- Require Dormitories to submit the Dormitory Covid 19 Prevention Protocol and establish a telephone hotline with Dormitory management

**3. Awareness Training of Covid-19 Prevention to all Employees**

All employees should be first sensitized via special training sessions and then always encouraged via ongoing training, promotion on companywide posters, pamphlets, or social media on the need to follow the Company Covid-19 Prevention Protocol. Some vendors have even set up separate company websites or workgroups to ensure updates and share, learnings, and best practices.

The supplier plan of return to work should be communicated in advance to workers to ensure the facilitation of social distancing.

**4. Introduction of Hand Hygiene and Respiratory Etiquette**

Employees should be instructed to:

- Frequently wash hands with soap and water for at least 20 seconds or, if soap and running water are unavailable, use an alcohol-based hand rub with at least 60% alcohol
- Always wash hands that are visibly soiled
- Avoid touching eyes, nose & mouth with unwashed hands
- Cough or sneeze into your elbow
- Avoid shaking hands, hugging or another physical contact
- Avoid crowds and close contact with people who are coughing, sneezing, flu-like symptoms or sick
- Avoid visiting areas affected by the epidemic and high-risk places
- Avoid touching suspected contaminated surfaces

**5. Sick Employee Management**

Employees who have symptoms of cough, fever (higher than 37.3°C), or acute respiratory illness are not allowed to come to work and should notify HR, their supervisor, and a doctor via a phone call. Ensure that your sick leave policies are flexible and consistent with public health guidance and that employees are aware of these policies.

All employees should declare their health status (including mild sickness), travel history in the past 14 days (including visits to epidemic-affected areas/countries), and contact with persons known to have contracted COVID-19.

## 6. Containment of Covid-19 Importation Risk From Employees

Employees who have visited epidemic-affected areas/countries in the past 14 days or had contact with persons known to have contracted COVID-19, including a family member at home, should inform by phone their HR representative or Supervisor immediately. Employers should conduct a risk assessment to determine potential exposure and instruct the employee to self-quarantine for 14 days.

Upon completion of quarantine, employees with body temperature <37.3°C and/or a medical clearance certificate are allowed to re-enter the factory.

## 7. Covid-19 Incident Protocol

Prepare a separate protocol for the unfortunate event of a Covid-19 infection in the workforce. The confidentiality of the Covid-19 infected person should be maintained. (Please also inform your LS&Co. Sustainability team contact of such an incident within 12 hours.)

### Communication and Confirmation

The supplier Emergency Response Team leader has the responsibility to monitor the Covid-19 situation in the factory and the community (city) where the factory is located. As soon as a confirmed case appears in the factory, the leader must immediately report it to the relevant Government authority or local disease control department.

The factory/vendor needs to inform a confirmed Covid-19 case within 12 hours of medical confirmation to the local sourcing management and sustainability team contacts.

The information given to the customer should state the following:

- Number of people confirmed,
- Their function at the facility
- Date and time the cases were confirmed
- The medical unit that confirmed the case (i.e., name and address of hospital)
- Details on any information or instructions provided by local health authorities
- Details on additional response actions that have been or will be taken by the vendors.

## 8. Factory Access Control

- Strict access control to factory premises. Employees should only have access to their required production areas and not linger or walk around the facility or visit areas not related

to their role. Outside visitors should be restricted to separate designated meeting rooms. This includes LS&Co. technical, quality, and merchandising personnel.

- Employees entering the factory should wear a mask and undergo a body temperature check. Anyone with body temperature >37.3°C should be stopped from entering the factory and sent either to the hospital for a medical examination or home for a 14-day self-quarantine. Please consider local health authority guidelines.
- The company should post information in areas accessible to workers on epidemic prevention, employee access control, and temperature screening procedures and requirements.
- It is recommended to have multiple entry points to avoid crowds and reduce waiting time.
- The company should stagger shift starting times to prevent large gatherings at entrances, canteens, or exits. For example, shifts could be divided into batches that start work 30 minutes earlier or later than others in order to ensure people waiting to enter the facility can keep an appropriate distance from one another.

## 9. Prevention Measures on the Production Floor

- Production lines should be separated by appropriate distances and/or partitions.
- It is recommended that management stagger shift starting times, meal breaks, and shift closings for every production line to avoid crowds gathering and reduce exposure to infection spread.
- Post educational posters on personal hygiene and prevention measures at different places around the production floor. Necessary breaks for handwashing should be paid.
- Companies should provide free masks and personal protective equipment (PPE) to workers, along with easily accessible hand washing and sanitization facilities.
- A specific team should monitor sanitization facilities and emergency supply inventory.
- Toilets should be cleaned and disinfected every hour.
- The production floor and rooms should be well ventilated.
- In the cases where work shifts are re-organized and fall outside of regular working hours, factory management should put in place clear protocols to mitigate safety risks to vulnerable workers, e.g., evening and night work shifts put women's safety at risk on their way back home.

## 10. Employee Dining – Canteen and Cafeteria Management

- Dining tables should be modified with partitions and situated at the proper distance from reach other.
- Canteen/Cafeteria crew should follow strict hygiene rules, washing their hands regularly, using masks when handling uncooked food (like salads or sandwiches) and when preparing or serving food.
- Meals should be served ready on dining tables whenever possible, instead of distributed from a single location, to avoid people gathering in long lines.
- Employees should wash their hands with soap before and after meals.



- It is recommended do not share food and eat using separate dishes.
- Dining out is not recommended. If dining out, it is recommended that employers order meals through contactless take-out service.
- Sterilize the canteen/cafeteria floors regularly every day, and sanitize tables, chairs, and tableware after each use.
- The operating area of the canteen/cafeteria should be kept clean and dry. It is strictly forbidden to mix raw and cooked food, and any meats should be cooked thoroughly.
- It is recommended that healthy and nutritious food be served whenever possible.
- Regularly inspect staff members of canteen/cafeteria as per the company's emergency prevention & control plan
- Canteen/cafeteria areas should be well ventilated. Disinfect doors, windows and knobs regularly every day. Regularly inspect and clean air conditioning and ventilation equipment.

#### 11. Meeting & Conference Room Management

- Avoid in-person meetings as much as possible. If they are absolutely necessary, keep them short and limited the number of attendees in accordance with local health regulations.
- It is recommended that you use audio-video technology whenever possible.
- People should follow personal hygiene practices before, during, and after meetings. This means wearing a mask, washing or sanitizing hands, and avoiding any handshaking or personal touching.
- People should maintain appropriate distances from each other while sitting.
- Documents should be disinfected before they are passed from person to person.
- Meeting rooms should be well ventilated, and all air conditioning and ventilation equipment should be cleaned regularly.
- Doors, windows, doorknobs and office equipment should be disinfected every day.
- Tea sets should be boiled or sterilized.

#### 12. Disinfection & Sanitization of Public Areas & Facilities

- Public areas such as meeting rooms, conference rooms, elevators, corridors, and wash-rooms should be disinfected every day.
- Centralized air conditioning systems should be cleaned regularly.
- Cleaning staff must wear face masks, latex gloves, and waterproof aprons. Goggles or other forms of protective eyewear are recommended to prevent cleaning materials from splashing into eyes and causing injury. Use different types of disinfectants for different purposes. For example: Disinfect non-porous surfaces with wipes and sterilize items by soaking

#### 13. Visitors & Outsourced Contractor Management

- It is recommended to have a separate entrance for visitors and outsourced contractors
- Visitors and outsourced contractors should be informed about Factory Access control and prevention measures before entering the factory.

- Outsiders must wear a mask and undergo a body temperature check before entering. Anyone with temperature >37.3°C should not be allowed to enter.
- Visitors and outsourced contractors should declare their health status (including any mild illness), travel history for the past 14 days (including visits to epidemic-affected areas/countries) and contacts with persons known to have contracted Covid-19.
- Allocate visitors and outsourced contractors to separate workplaces or rooms. These workplaces/rooms should be disinfected regularly.
- Only designated employees should be allowed to contact or work with outsiders.

#### 14. Transportation Vehicles & Driver

##### ***Recommendations for factories with workers using PUBLIC transport.***

- Suppliers and workers should understand government measures to ensure safety in public transport. Based on the level of confidence, explore private options.
- Suppliers should support workers' efforts to avoid rush times in public transport and prevent them from rushing for transportation as that can result in a failure to observe proper hygiene requirements.
- Suppliers should set specific medical screening for workers using public transport (e.g.: more frequent temperature measurement).
- Educate workers on the importance of practicing good handwashing or sanitizing hygiene, along with proper cough/sneeze hygiene, before and during the journey.
- Educate workers on the need to always cover their mouths when coughing or sneezing, to dispose of tissues, and to use alcohol-based hand sanitizer during their journey.
- Workers are recommended to wear masks during their commute while maintaining proper social distancing. They should wash or disinfect their hands at the entrance to the factory as well.

##### ***Recommendations for factories that offer PRIVATE transportation to workers:***

- Educate workers on the importance of practicing good hand hygiene and coughing/sneezing hygiene before and during journey.
- Recommend that workers wash their hands with soap and water, before and after transport.
- Educate workers on the need to always cover their mouths when coughing or sneezing, to dispose of tissues, and to use alcohol-based hand sanitizer during their journey
- Employees who have symptoms of cough, fever (>37.3°C ), or acute respiratory illness should not board the bus.
- If anyone is unwell, **do not allow them to take the transport.** Make sure they avoid contact with others, keeping a distance of more than 1.5 meters from others, then follow the guidelines of local health authorities to define the next steps.
- Company vehicles must be disinfected regularly, preferably after every trip.
- Screen and monitor the health of drivers before each journey.

- Check the temperature of all workers before they board the bus.
- Install sanitizer into each transport vehicle.
- Make it mandatory for workers to wear masks throughout the journey.
- To uphold social distancing, either add more buses or explore additional shifts, so that all workers do not come at one time.
- Avoid direct contact with other passengers, drivers, and transport staff.
- Recommended that there be a separate designated unloading area, parking spaces for outside vehicles, and waiting/sitting areas for drivers, which should be disinfected regularly

**Recommendations for factories to manage visitors safely:**

- It is recommended that factories assign separate company vehicles and drivers to pick up and drop off different groups of visitors and to keep a record of details of contact with visitors, including the date and time of each trip.
- Outside vehicles and drivers should be informed about Factory Access control and prevention measures before entering the factory.
- Outsiders must wear mask and undergo body temperature checks. Anyone with temperature >37.3°C should not be allowed to enter.
- Outsiders should declare their health status (including mild sickness), travel history in the past 14 days (including visits to epidemic-affected areas/countries) and contacts with anyone known to have contracted Covid-19.

**15. Preparing Operations for Post-lockdown.**

Beyond government requirements, use the above **Emergency Response Plan (ERP)** to initiate your operations after lockdown. To execute the above ERP, the classification of workers' exposure is critical. For that reason, we attached the following ANNEX that must be followed appropriately.

**Covid-19 Preventive Recommendations for Vendors – ANNEX**

**Classification of worker exposure**

It is critical to Classify Worker Exposure to help employers determine appropriate precautions; good practice requires dividing job tasks into four exposure levels. **Footwear, apparel, and leather industry factories typically have Medium- and Low-exposure jobs; the specific level depends on whether or not an individual's job requires them to interact with others.**

**15.1. High-exposure jobs** are those with high potential for exposure to known or suspected sources of Covid-19 during specific medical procedures. This would include healthcare workers, such as doctors or nurses, and requires the following:

- **Engineering controls:** Ensure appropriate air-handling systems filtered, tempered supplied-air full-face mask systems are installed and maintained in healthcare facilities. The employer should use isolation rooms when available for performing aerosol-generating procedures on patients with known or suspected Covid-19. **High-exposure jobs typically are not found in the footwear, apparel and leather industry.**
- **Administrative and behavioral controls;**
  - Develop and implement policies that reduce exposure, such as cohorting (i.e., grouping) Covid-19 patients when single rooms are not available.
  - Post signs requesting that patients and family members immediately report symptoms of respiratory illness on arrival at the facility and use disposable face masks while on the premises.
  - Provide all workers with job-specific education and training on preventing transmission of Covid-19, including initial and routine/refresher training.
- **Personal Protective Equipment (PPE) controls:** Most workers at high or very high exposure risk likely need to wear gloves, a gown, a face shield or goggles, and either a face mask or a respirator, depending on their job tasks and exposure risks. Those who work closely with (either in contact with or within 6 feet, 1.8 m of) patients known to be, or suspected of being, infected with SARS-CoV-2, the virus that causes Covid-19, should wear respirators. For the most up-to-date information, visit local authorities Covid-19 webpage or check WHO and OSHA guidelines.
  - Occupational Safety and Health Administration website: [www.osha.gov](http://www.osha.gov)
  - Centers for Disease Control and Prevention website: [www.cdc.gov](http://www.cdc.gov)
  - National Institute for Occupational Safety and Health website: [www.cdc.gov/niosh](http://www.cdc.gov/niosh)
  - World Health Organization website: <https://www.who.int/emergencies/diseases/nov-el-coronavirus-2019>

- 
- PPE ensembles may vary. Additional PPE may include medical/surgical gowns, fluid-resistant coveralls, aprons, or other disposable or reusable protective clothing. Gowns should be large enough to cover the areas requiring protection. Local authorities may also provide updated guidance on PPE use on their websites.

**NOTE:** Workers who dispose of PPE and other infectious waste must also be trained and provided with appropriate PPE.

**15.2. Medium-exposure jobs** include roles that require frequent and close contact with (i.e., within 6 feet, 1.8 m of) people who may be infected. **Workers in this category may have contact with the general public in places such as schools, high-population-density work environments like footwear, apparel and leather industry factories, or high-volume retail settings. In these settings, the following is required:**

- **Engineering controls:** Install physical barriers, such as clear plastic sneeze guards, where feasible.
- **Administrative and behavioral controls:**
  - Offer face masks to all workers, employees, and customers to contain respiratory secretions until they can leave the workplace. In the event of a shortage of masks, **manufacturing its own a reusable face shield.**
  - Keep workers informed about symptoms of Covid-19 and ask sick visitors, business contacts, or consumers to minimize contact with workers until healthy again.
  - Where appropriate, limit workers' movements or restrict access to designated workplace areas.
  - Consider strategies to minimize face-to-face contact (e.g., drive-through windows, phone-based communication, telework).
  - Communicate the availability of medical screening or other worker health resources (e.g., on-site nurse; telemedicine services).
- **Personal Protective Equipment (PPE) controls:** Workers with medium exposure risk must wear a face mask and observe comprehensive individual and collective hygiene protocols.

**15.3. Lower-exposure (Caution) jobs** are roles that do not require contact with people known to be or suspected of being infected or frequent close contact with (i.e., within 6 feet/1.8 meters of) the general public. **Workers in this category have minimal occupational contact with the public and other coworkers.** In these settings, the following is required:

- **Engineering controls:** Additional engineering controls are not recommended for workers in the lower exposure risk group. Employers should ensure that engineering controls used to protect workers from other job hazards continue to function as intended.

- 
- **Administrative and behavioral controls:** Monitor public health recommendations and ensure that workers have access to that information. Collaborate with workers to designate effective means of communicating important Covid-19 information.
  - **Personal Protective Equipment (PPE) controls:** Additional PPE is not recommended for workers in the lower exposure risk group. Workers should continue to use the PPE that they would ordinarily apply for other job tasks.

# Annex C: Environment Guidelines

## WASTE MANAGEMENT

### Transporting Hazardous Materials

#### Hazmat Transportation Inspections Information Loading/Unloading Inspection

**Objective:** To reduce the frequency of hazardous materials loading and unloading incidents through regular inspections of loading and unloading equipment and procedures.

**Description:** A large majority of hazardous materials incidents occur during loading and unloading operations. Providing adequate supervision of these operations and inspecting material handling equipment regularly may reduce the number of Hazmat incidents at this stage of the transportation process.

#### Questions for Management:

1. Are all loading/unloading operations supervised or conducted by experienced staff?
2. Are flammable materials and explosives kept away from sources of ignition or heat sources (including cargo heater and air conditioning units)?
3. Are you complying with applicable federal, state, provincial, and/or local regulations regarding the compatibility of hazardous materials per the Segregation Table for Hazardous Materials?

#### Tip for Management:

- Be aware that certain chemicals react with air or water and require special loading/unloading equipment.

#### Tips for Hazmat Employees:

- Contact management if a suspicious shipment is offered.
- Check the compatibility of mixed loads.
- Check the weight distribution of loads.
- Verify that the cargo is properly secured.

- Check the type, number, and stacking arrangement of load.
  - Ensure that the load will not swing over the cab during loading/unloading.
  - Ensure cylinders are kept positioned correctly and that temperatures are kept within a safe range.
  - Verify that tank trucks are grounded prior to loading and unloading.
  - Prior to loading bulk loads, inspect the tank for objects which are not bonded.
  - Inspect valves, connections, emergency shutoff valves, and pipes before loading.
  - Verify that container is safe for filling.
  - Verify that all truck electrical systems are off before loading or unloading.
- Conduct a walk-around inspection prior to driving away.

#### Vehicle Inspection

**Objective:** To reduce the frequency of vehicle breakdowns and hazardous materials incidents by thorough and regular inspections of fleet vehicles.

**Description:** Regular vehicle inspection is an integral part of the maintenance program of fleet vehicles. Inspections by qualified personnel dramatically reduce the number of vehicle breakdowns and malfunctions thereby improving overall vehicle fleet operations efficiency and helping to reduce the number of hazardous materials incidents.

#### Questions for Management:

1. Are vehicles subject to comprehensive pre-trip and post trip inspections?
2. Are vehicles and loads systematically inspected at regular intervals during a trip?
3. Are frequent functional tests carried out?
4. Are vehicles appropriate for their hazardous materials cargo?
5. Are flammable solids or oxidizers carried in closed cargo spaces?
6. Do vehicles have tight floors where required?

#### Tips for Management:

- Thoroughly inspect and test vehicles periodically for safe operation.
- Be sure that vehicle repairs are performed in a timely fashion.
- Keep records of results and dates of vehicle inspections and repairs.

#### Tips for Drivers:

- Check for loose, worn or leaking parts.

- 
- Check pressure, temperature, liquid levels and gauges before setting out.
  - Adjust mirrors.
  - Check for hot brakes regularly.
  - Do not drive your vehicle unless it is safe to do so.

### Packaging Inspection

**Objective:** To reduce the frequency of accidental leaks of hazardous materials due to incompatible or damaged packages by conducting thorough inspections of packages prior to and during the transportation process.

**Description:** Use of correct packaging is the single most effective measure in reducing hazardous materials incidents. Inadequate packaging can result in costly and damaging Hazmat incidents. These incidents can often be prevented by conscientiously inspecting all packages and containers.

#### Questions for Management:

1. Is there a quality control program in effect to ensure the monitoring of package integrity on a regular basis?
2. Is authorized packaging used for hazardous materials?
3. Are sample packages subject to performance testing such as a drop test?
4. Are cylinder scales frequently calibrated to maintain accuracy?
5. Are Hazmat employees aware that flammable bulk packages must be grounded or bonded?
6. Are material-specific leak detectors used to detect leakage and/or permeation?

#### Tip for Management:

- Require and encourage Hazmat employees to perform visual inspections of packages as they are loaded and unloaded.

#### Tips for Hazmat Employees:

- Be alert for containers which are under- or over-filled.
- Properly clean, purge, and inspect containers to ensure there is no residue from previous loads.
- Inspect over-fill protection systems for proper operation.
- Inspect pressure, temperature and liquid-level gauges.
- Ensure valve-protecting caps and collars are in place on cylinders of compressed gases, if required.

- 
- Inspect containers and packages to ensure that they are properly labeled and marked.
  - Ensure that containers and packages are secure.
  - Inspect the stacking arrangements of all loads, including blocking and bracing.
  - Ensure that cargo has the appropriate ventilation.
  - Inspect all tank mountings.

### Safety Equipment Inspection

**Objective:** To ensure that safety equipment is in good working order through regular and thorough inspections.

**Description:** Properly functioning safety equipment for vehicles, plant machinery and personnel are essential for reducing the frequency and severity of hazardous materials incidents. Therefore, it is vital that complete inspections of safety equipment be routinely performed by qualified personnel.

#### Questions for Management:

1. Is all safety equipment inspected on a regular and scheduled basis?
2. Is safety equipment on vehicles—including fire extinguishers and personal protection equipment—inspected before setting out?
3. Should spare parts, such as headlamps and directional bulbs, be carried with each vehicle?
4. Is the personal protective equipment provided to Hazmat employees suitable for the hazardous materials being handled?
5. Are Hazmat employees trained to inspect chemical respirators since this equipment has a finite life once exposed to atmosphere or chemicals?
6. Are compressed-gas cylinder safety devices checked regularly?

#### Tips for Management:

- Provide checklists for all equipment inspections and require their use.
- Keep records of all equipment inspections and review periodically.

#### Tips for Hazmat Employees:

- Check vehicle maintenance log for last servicing date and findings.
- Inspect emergency/remote shutoff valves at beginning of each shift or as part of pre-trip inspection.

---

## Labeling Inspection

**Objective:** To promote effective communication of hazards associated with shipments by the visual inspection of package labeling.

**Description:** The purpose of package labels is to communicate the primary hazards of the material being shipped. Hazmat employees handling the package should be familiar with the labels in order to be aware of and to respect the potential dangers of the material. Emergency responders also need this information in order to respond correctly in case of an incident. Regular inspections of package labeling may detect packages which are not in compliance with federal regulations.

### Questions for Management:

1. Are all samples which are transported labeled for hazard class?
2. Should a reference table be provided to the drivers for interpreting numerical markings and labels?
3. Are carrying capacities marked on tanks, cylinders, and trucks?

### Tips for Management:

- Alert employees to the importance of package labeling.
- Encourage employees to check package labeling.

### Tip for Hazmat Employees:

- Inspect labels to ensure that they match shipping papers.

## Shipping Papers and Classification Inspection

**Objective:** To ensure that the information contained in the shipping papers is complete and corresponds to the hazardous materials being transported.

**Description:** The shipping papers will quickly identify the hazardous materials involved in a Hazmat incident. For this reason, it is critical that the information contained in the documents be accurate. Emergency responders rely heavily on shipping papers for properly identifying materials as well as for finding sources of technical assistance.

---

### Questions for Management:

1. Are hazardous materials clearly identified on shipping papers?
2. Do you have most recent emergency response information?
3. If Material Safety Data Sheets (MSDS) or equivalent documents refer to personal protection equipment such as respirators, is this equipment available?

### Tips for Management:

- Alert employees to the importance and use of shipping papers in both routine and emergency situations.
- Encourage employees to inspect shipping papers for content and format.

### Tips for Hazmat Employees:

- Be sure that emergency response information is immediately available for use at all times.
- Check that shipping papers are legible, complete, and that all listed hazardous materials are easily identifiable.
- Check that shipping papers are stored for easy access.
- Check to ensure that shipment matches shipping papers, placards, markings and labels.

## Placarding Inspection

**Objective:** To ensure that proper placards appear on the exterior of a vehicle.

**Description:** In the event of a hazardous materials incident, placards are often the first source of information used in evaluating the hazards of an unidentified Hazmat shipment. The inspection of vehicle placards prior to departure will ensure that the information displayed is accurate.

### Questions for Management:

1. Are vehicles equipped with the proper tools for attaching placards?
2. Are placards being offered by the shipper to the carrier?
3. Is the carrier placing the placards on the vehicle?
4. Are replacement placards available to Hazmat employees?

---

**Tips for Management:**

- Train Hazmat employees to properly choose placards.
- Consider the use of separate placards versus the use of flip- type placards.

**Tips for Hazmat Employees:**

- Inspect placards prior to departure to ensure they are clean and legible.
- Verify that the placards match the shipping papers.
- Clean any dirty placards.
- Replace any damaged or illegible placards.
- Remove or change the placards only when it is appropriate to do so.

---

**WASTE  
MANAGEMENT****Transporting Hazardous Materials  
Sample Bulk Fuel Oil Transfer Procedures**

A release of fuel oil or other bulk chemicals can cause harm to nearby populations and the environment. Therefore, special precautions are taken to prevent a release when fuel oil is delivered to the premises.

The following procedures have been established to prevent the release of diesel during fueling operations:

1. Tanker trucks are received by appointment only.
2. The tanker truck driver engages the vehicle break interlock system to prevent the vehicle from departing before complete disconnection of flexible or fixed oil transfer lines.
3. Before fueling begins, factory personnel cover any storm drains within close proximity to the fuel truck.
4. The truck driver runs the hose from the tanker truck to the fill pipe inlet.
5. A factory employee familiar with hazardous materials and emergency response procedures is present during the entire fueling process to respond immediately to any of the following conditions:
  - An alarm triggered by over-filling the tank;
  - An alarm triggered by a breach of the system resulting in a release of diesel from the tank;
  - Leaks from the hose during fueling; or
  - Any other condition that indicates a spill or release of fuel oil.
6. Absorbent pads, booms, and other emergency response materials are maintained nearby fueling operations so that a spill or release can be immediately contained.

**WASTE MANAGEMENT**

**Hazardous Materials and Waste Management – Emergency Procedures**

**Emergency Procedures**  
(Post near telephones and as appropriate)

In case of a fire, spill, or other emergency involving hazardous chemicals or wastes, do the following:

**MAJOR EMERGENCY**

- Evacuate the affected areas per the facility Evacuation Plan
- Call \_\_\_\_\_ and report the emergency
- Report the emergency to the Facility Emergency Coordinator

**MINOR EMERGENCY**

- Try to control the emergency if you are trained to do so and can do it safely
- Report the emergency to the Facility Emergency Coordinator

**Facility Emergency Coordinators**

Name	Work Phone	24-Hour Phone
Primary EC		
1st Alternate EC		
2nd Alternate EC		
3rd Alternate EC		

Agency	Phone number
Fire Dept., Ambulance, Police	
Spill Response Contractor (if applicable)	
Local Government Agencies	

**Emergency Equipment**

Locations of fire extinguishers, fire alarms (if any), and equipment for controlling chemical spills are shown on the facility site plan posted with this notice.

This document is only a summary of emergency procedures. Refer to this facility's written emergency response plan for detailed procedures.

**WASTE MANAGEMENT**

**Sample Facility Site Plan/Storage Map**

Site Address: \_\_\_\_\_

Date Map Drawn: \_\_\_/\_\_\_/\_\_\_\_. Map Scale: \_\_\_\_\_ Page \_\_\_ of \_\_\_

	A	B	C	D	E	F	G	H	I	J	K	L	M	N	O	P	Q	R	S	T	U	V	W	X	Y	Z
1																										
2																										
3																										
4																										
5																										
6																										
7																										
8																										
9																										
10																										
11																										
12																										
13																										
14																										
15																										
16																										
17																										
18																										
19																										
20																										
21																										
22																										
23																										
24																										
25																										
26																										
27																										
28																										

Instructions: It is recommended that the map contain the following information:

- A. General purpose of each section/area within each building (e.g., "Office Area", "Manufacturing Area", etc.);
- B. Location of each hazardous material/waste storage, dispensing, use, or handling area (e.g., individual under-ground tanks, aboveground tanks, storage rooms, etc.). Each area shall be identifiable by a Grid Number for easy reference.



- C. For tanks, the capacity limit in gallons and common name of the hazardous material contained in each tank.
- D. Entrances to and exits from each building and hazardous material/waste room/area;
- E. Location of each utility emergency shut-off point (i.e., gas, water, electric.); and
- F. Location of each monitoring system control panel (e.g., underground tank monitoring, toxic gas monitoring, etc.).

**WASTE MANAGEMENT**

**Facility Evacuation Map Template**

Site Address: \_\_\_\_\_

*Note: This map must show primary and alternate evacuation routes, emergency exits, and primary and alternate staging areas.*

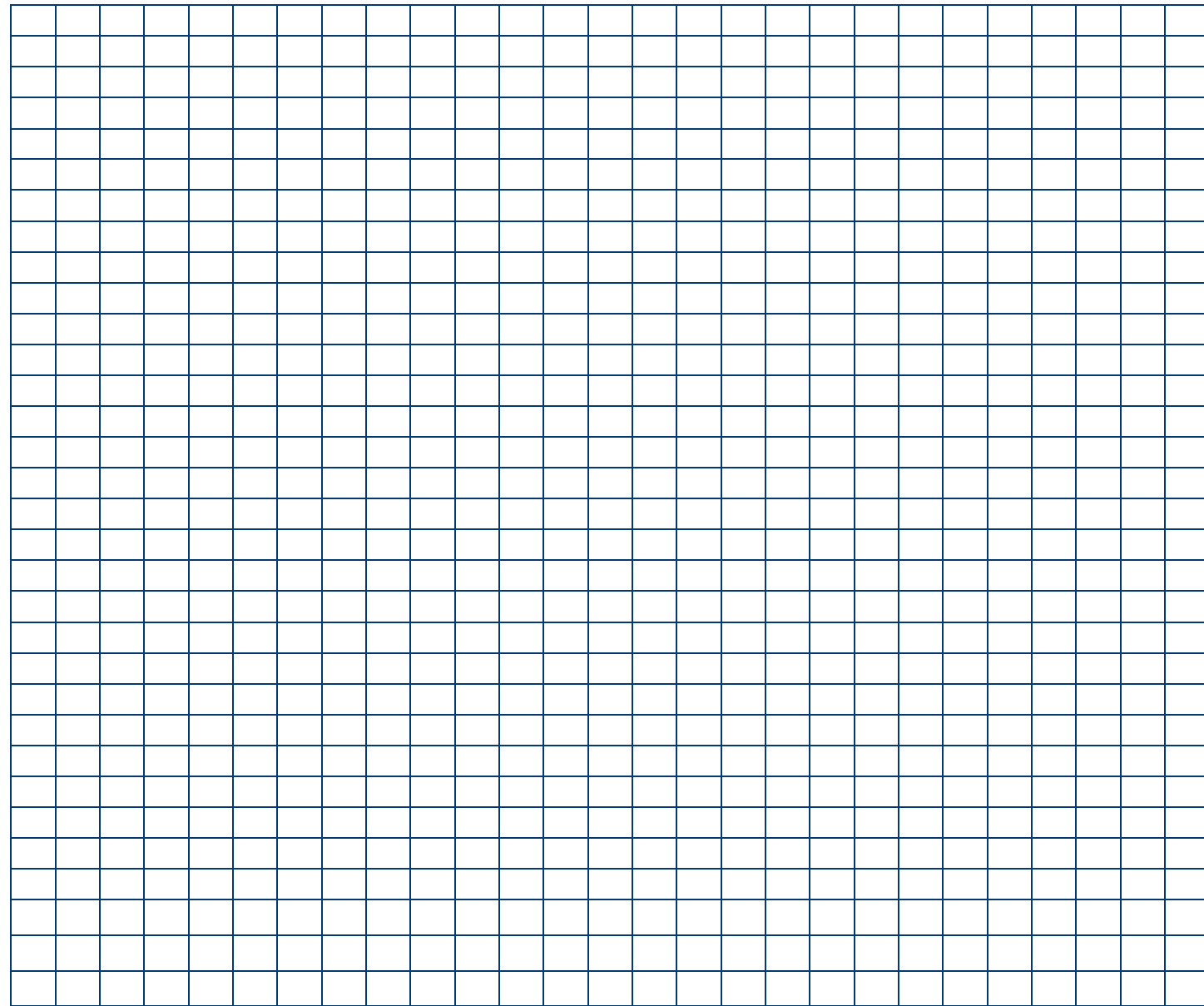

**WASTE MANAGEMENT**

**Sample Hazardous Waste Storage Area Weekly Inspections Checklist**

Inspector Name \_\_\_\_\_ Date \_\_\_\_\_ Time \_\_\_\_\_

Location of inspection \_\_\_\_\_ Total number of containers \_\_\_\_\_

	Yes	No	
1. Is the area free of debris and other materials?	<input type="checkbox"/>	<input type="checkbox"/>	
2. Is the ground clean and dry?	<input type="checkbox"/>	<input type="checkbox"/>	
3. Are container tops free of spillage?	<input type="checkbox"/>	<input type="checkbox"/>	
4. Is the area free of spills or leaks?	<input type="checkbox"/>	<input type="checkbox"/>	
5. Are all of the containers in good condition? (free of dents and corrosion, not bulging, or otherwise deteriorating?)	<input type="checkbox"/>	<input type="checkbox"/>	
6. Are all containers properly closed?	<input type="checkbox"/>	<input type="checkbox"/>	
7. Are containers labeled with hazardous waste labels?	<input type="checkbox"/>	<input type="checkbox"/>	
8. Is the following information on the labels filled out?			
	Generator name and address	<input type="checkbox"/>	<input type="checkbox"/>
	Accumulation start date	<input type="checkbox"/>	<input type="checkbox"/>
	Contents	<input type="checkbox"/>	<input type="checkbox"/>
	Physical state	<input type="checkbox"/>	<input type="checkbox"/>
	Hazardous properties	<input type="checkbox"/>	<input type="checkbox"/>
9. Is the information on the labels legible?	<input type="checkbox"/>	<input type="checkbox"/>	
10. Have wastes been disposed of within the allowable accumulation time?	<input type="checkbox"/>	<input type="checkbox"/>	
11. Are the containers compatible with their contents?	<input type="checkbox"/>	<input type="checkbox"/>	
12. Are incompatible wastes stored separately?	<input type="checkbox"/>	<input type="checkbox"/>	
13. Is there adequate aisle space?	<input type="checkbox"/>	<input type="checkbox"/>	

Describe any observations for items checked "NO"

Corrective Action required

**WASTE  
MANAGEMENT**

**Emergency Procedures for Spill or  
Release**

**A. Facility Information**

BUSINESS NAME		BUSINESS PHONE	
		( )	
SITE ADDRESS	CITY	STATE/PROV	
COUNTRY/CODE			

**B. Emergency Coordinators**

All personnel qualified to act as the facility's Emergency Coordinator must be listed in this plan. (Note: Emergency Coordinator responsibilities are described in Section E, below.) If more than two people are qualified, list the names, titles, business and 24- hour telephone numbers, and pager numbers of the additional qualified individuals on an attached page in the order in which they will assume responsibility as alternates, then check the box beneath the Emergency Coordinator information table, below, and indicate the list's page number in the space provided.

Primary Emergency Coordinator	Secondary Emergency Coordinator
NAME	NAME
TITLE	TITLE
BUSINESS PHONE	BUSINESS PHONE
( )	( )
24-HOUR PHONE	24-HOUR PHONE
( )	( )
PAGER#	PAGER#
( )	( )
<input type="checkbox"/> (Check box only if applicable) Additional Emergency Coordinators are listed on page _____ of this plan.	

**C. Evacuation Plan**

The following alarm signal(s) will be used to begin evacuation of the facility (check all that apply):

- Bells;  
  Horns/Sirens;  
  Verbal (e.g., shouting);  
  Other (specify) \_\_\_\_\_  
 Evacuation map is prominently displayed throughout the facility.

**D. Emergency Contacts**

Fire/Police/Ambulance \_\_\_\_\_ Phone No \_\_\_\_\_

**Authorities :**

(Name) \_\_\_\_\_ Phone No \_\_\_\_\_

(Name) \_\_\_\_\_ Phone No \_\_\_\_\_

(Name) \_\_\_\_\_ Phone No \_\_\_\_\_

**Arrangements with Emergency Responders:**

If you have made special (i.e., contractual) arrangements with any police department, fire department, hospital, contractor, or local emergency response team to coordinate emergency services, describe those arrangements below:

---



---



---

**E. Emergency Procedures:**

**Emergency Coordinator Responsibilities:**

- Whenever there is an imminent or actual emergency situation such as an explosion, fire, or release, the emergency coordinator (or his/her designee when the emergency coordinator is on call) shall:
  - Identify the character, exact source, amount, and a real extent of any released hazardous materials.
  - Assess possible hazards to human health or the environment that may result from the explosion, fire, or release. This assessment must consider both direct and indirect effects (e.g. the effects of any toxic, irritating, or asphyxiating gases that are generated, the effects of any hazardous surface water run-off from water or chemical agents used to control fire, etc.).
  - Activate internal facility alarms or communications systems, where applicable, to notify all facility personnel.
  - Notify appropriate local authorities
  - Monitor for leaks, pressure build-up, gas generation, or ruptures in valves, pipes, or other equipment shut down in response to the incident.
  - Take all reasonable measures necessary to ensure that fires, explosions, and releases do not occur, recur, or spread to other hazardous materials at the facility.
  
- Before facility operations are resumed in areas of the facility affected by the incident, the emergency coordinator shall:
  - Provide for proper storage and disposal of recovered waste, contaminated soil or surface water, or any other material that results from an explosion, fire, or release at the facility.
  - Ensure that no material that is incompatible with the released material is transferred, stored, or disposed of in areas of the facility affected by the incident until cleanup procedures are completed.
  - Ensure that all emergency equipment is cleaned, fit for its intended use, and available for use.
  - Notify local authorities, if required, that the facility is in compliance with requirements b-i and b-ii, above.

**Responsibilities of Other Personnel:**

On a separate page, list any emergency response functions not covered in the “Emergency Coordinator Responsibilities” section, above. Next to each function, list the job title or name of each person responsible for performing the function. Number the page(s) appropriately.

**F. Post-Incident Reporting/Recording**

The time, date, and details of any hazardous materials incident that requires implementation of this plan shall be noted in the facility’s operating record.

The report should include:

- Name, address, and telephone number of the facility’s owner/operator;
- Name, address, and telephone number of the facility;
- Date, time, and type of incident (e.g. fire, explosion, etc.);
- Name and quantity of material(s) involved;
- The extent of injuries, if any;
- An assessment of actual or potential hazards to human health or the environment, where this is applicable;
- Estimated quantity and disposition of recovered material that resulted from the incident;
- Cause(es) of the incident;
- Actions taken in response to the incident;
- Administrative or engineering controls designed to prevent such incidents in the future; AND
- ANY OTHER INFORMATION REQUIRED BY LOCAL AUTHORITIES.

**G. Earthquake Vulnerability**

Identify any areas of the facility and mechanical or other systems that require immediate inspection or isolation because of their vulnerability to earthquake-related ground motion:

---



---



---



---

**H. Emergency Equipment**

**Emergency Equipment Inventory Table**

Equipment Category	Equipment Type	Locations*	Description**
<b>Personal Protective Equipment, Safety Equipment, and First Aid Equipment</b>	<input type="checkbox"/> Cartridge Respirators		
	<input type="checkbox"/> Chemical Monitoring Equipment (describe)		
	<input type="checkbox"/> Chemical Protective Aprons/Coats		
	<input type="checkbox"/> Chemical Protective Boots		
	<input type="checkbox"/> Chemical Protective Gloves		
	<input type="checkbox"/> Chemical Protective Suits (describe)		
	<input type="checkbox"/> Face Shields		
	<input type="checkbox"/> First Aid Kits/Stations (describe)		
	<input type="checkbox"/> Hard Hats		
	<input type="checkbox"/> Plumbed Eye Wash Stations		
	<input type="checkbox"/> Portable Eye Wash Kits (i.e. bottle type)		
	<input type="checkbox"/> Respirator Cartridges (describe)		
	<input type="checkbox"/> Safety Glasses/Splash Goggles		
	<input type="checkbox"/> Safety Showers		
<input type="checkbox"/> Self-Contained Breathing Apparatuses (SCBA)			
<input type="checkbox"/> Other (describe)			
<b>Fire Extinguishing Systems</b>	<input type="checkbox"/> Automatic Fire Sprinkler Systems		
	<input type="checkbox"/> Fire Alarm Boxes/Stations		
	<input type="checkbox"/> Fire Extinguisher Systems (describe)		
	<input type="checkbox"/> Other (describe)		
<b>Spill Control Equipment and Decontamination Equipment</b>	<input type="checkbox"/> Absorbents (describe)		
	<input type="checkbox"/> Berms/Dikes (describe)		
	<input type="checkbox"/> Decontamination Equipment (describe)		
	<input type="checkbox"/> Emergency Tanks (describe)		
	<input type="checkbox"/> Exhaust Hoods		
	<input type="checkbox"/> Gas Cylinder Leak Repair Kits (describe)		
	<input type="checkbox"/> Neutralizers (describe)		
	<input type="checkbox"/> Overpack Drums		
	<input type="checkbox"/> Sumps (describe)		
	<input type="checkbox"/> Other (describe)		

Equipment Category	Equipment Type	Locations*	Description**
<b>Communications and Alarm Systems</b>	<input type="checkbox"/> Chemical Alarms (describe)		
	<input type="checkbox"/> Intercoms/ PA Systems		
	<input type="checkbox"/> Portable Radios		
	<input type="checkbox"/> Telephones		
	<input type="checkbox"/> Underground Tank Leak Detection Monitors		
	<input type="checkbox"/> Other (describe)		
<b>Additional Equipment</b> (Use Additional Pages if Needed.)	<input type="checkbox"/>		
	<input type="checkbox"/>		
	<input type="checkbox"/>		
	<input type="checkbox"/>		
	<input type="checkbox"/>		

\* Describe location or use the map to determine grid numbers.

\*\* Describe the equipment and its capabilities. If applicable, specify any testing/maintenance procedures/intervals. Attach additional pages, numbered appropriately, if needed.

## I. Employee Training Plan

Check all boxes that apply.

### 1. Personnel are trained in the following procedures:

- Internal alarm/notification
- Evacuation/re-entry procedures & assembly point locations
- Emergency incident reporting
- External emergency response organization notification
- Location(s) and contents of Emergency Response/Contingency Plan
- Facility evacuation drills, that are conducted at least (specify) (e.g., "Quarterly", etc.)

### 2. Chemical Handlers are additionally trained in the following:

- Safe methods for handling and storage of hazardous materials
- Location(s) and proper use of fire and spill control equipment
- Spill procedures/emergency procedures
- Proper use of personal protective equipment
- Specific hazard(s) of each chemical to which they may be exposed, including routes of exposure (i.e., inhalation, ingestion, absorption)
- Hazardous Waste Handlers/Managers are trained in all aspects of hazardous waste management specific to their job duties (e.g., container accumulation time requirements, labeling requirements, storage area inspection requirements, manifesting requirements, etc.)\*

### 3. Emergency Response Team Members are capable of and engaged in the following:

- Safe methods for handling and storage of hazardous materials
- Location(s) and proper use of fire and spill control equipment
- Spill procedures/emergency procedures
- Proper use of personal protective equipment
- Specific hazard(s) of each chemical to which they may be exposed, including routes of exposure (i.e., inhalation, ingestion, absorption)
- Hazardous Waste Handlers/Managers are trained in all aspects of hazardous waste management specific to their job duties (e.g., container accumulation time requirements, labeling requirements, storage area inspection requirements, manifesting requirements, etc.) \*

## J. Record Keeping

- All facilities that handle hazardous materials must maintain records associated with their management. A blank summary has been provided below as a guideline. Refer to local laws and regulations for required records and/or specific record retention requirements that are more stringent than these guidelines.

- The following records are maintained at the facility. (Check all boxes that apply.)
  - Current employees' training records (to be retained until closure of the facility) \*
  - Former employees' training records (to be retained at least three years after termination of employment) \*
  - Training Program(s) (i.e., written description of introductory and continuing training) \*
  - Current copy of this Emergency Response/Contingency Plan \*
  - Record of recordable/reportable hazardous material/waste releases \*
  - Record of hazardous material/waste storage area inspections \*
  - Record of hazardous waste tank daily inspections \*
  - Description and documentation of facility emergency response drills

Note: The above list of records does not necessarily identify every type of record required to be maintained by the facility.

#### K. Amendment of Contingency Plan

This plan must be reviewed, and immediately amended, if necessary, whenever:

1. Applicable regulations are revised.
2. The plan fails in an emergency.
3. The facility changes its design, construction, operation, maintenance, or other circumstances in a way that materially increases the potential for fires, explosions, or releases of hazardous waste or hazardous waste constituents, or changes the response necessary in an emergency.
4. The list of emergency coordinators changes.
5. The list of emergency equipment changes.

## WASTE MANAGEMENT

### Typical Hazardous Materials Inspection Violations

The following is a list of typical violations often found by inspectors and a generic solution. You can use this list to improve the safety of your facility, to prepare for an upcoming inspection, or to develop your own self inspection program. Note that specific code requirements may vary somewhat from jurisdiction to jurisdiction, so if you have questions or would like to know the specific code sections, please contact your local agency. (The reference number is used to make it easier to identify specific items; it does not refer to a code or ordinance.)

#### I. Typical Secondary Containment Violations

No.	General type	Description
150	Repair	<ul style="list-style-type: none"> <li>Ⓡ Deterioration of secondary containment structure/coating observed.</li> <li>Ⓢ Repair deterioration of the secondary containment structure.</li> </ul>
151	Spill/Drainage Control	<ul style="list-style-type: none"> <li>Ⓡ Failure to provide adequate spill or drainage control for solid or liquid hazardous materials.</li> <li>Ⓢ Rooms, buildings or areas used for the storage of solid and liquid hazardous materials shall be provided with a means to control spillage and to contain or drain off spillage and fire-protection water discharged in the storage area.</li> <li>Ⓢ Rooms or areas where hazardous material liquids are dispensed, stored, or used, shall be provided with a means to control spills.</li> </ul>
152	Secondary Containment	<ul style="list-style-type: none"> <li>Ⓡ Failure to provide secondary containment, or</li> <li>Ⓡ Secondary containment not adequately sized.</li> <li>Ⓢ Provide acceptable secondary containment for hazardous materials storage system.</li> </ul>
153	Dry	<ul style="list-style-type: none"> <li>Ⓡ Failure to maintain containment area clean and dry.</li> <li>Ⓢ Clean secondary containment. Review procedures to prevent future releases.</li> </ul>
154	Spills	<ul style="list-style-type: none"> <li>Ⓡ Failure to clean up spills of hazardous materials.</li> <li>Ⓢ All hazardous materials spills must be cleaned up immediately and recorded. Spills that escape secondary containment must be reported to Hazardous Materials Division. Spills that enter the storm sewer or pose a fire, explosion, or toxic gas release shall be reported to 911 immediately.</li> </ul>

#### II. Typical Separation Violations

No.	General type	Description
150	Separation	<ul style="list-style-type: none"> <li>Ⓡ Failure to separate incompatible materials.</li> <li>Ⓢ Separate incompatible materials by:</li> <li>Ⓢ Segregating incompatible hazardous materials storage by a distance of not less than 20 feet,</li> <li>3. Isolating incompatible hazardous materials storage by a noncombustible partition extending not less than 18 inches above and to the sides of the stored material, or</li> <li>4. Storing in hazardous materials storage cabinets or gas cabinets. Materials which are incompatible shall not be stored within the same cabinet.</li> </ul>

No.	General type	Description
151	<b>Oxidizer Storage/ Contamination</b>	<ul style="list-style-type: none"> <li>Ⓡ Oxidizers shall not be stored on or against combustible surfaces.</li> <li>Ⓢ Organic peroxides shall be stored in their original DOT shipping containers.</li> <li>Ⓢ During storage, care shall be taken to prevent contamination.</li> </ul>

### III. Typical Monitoring Violations

No.	General type	Description
300	<b>Monitoring</b>	<ul style="list-style-type: none"> <li>Ⓡ Failure to provide monitoring for an existing storage system, storage facility, or secondary containment.</li> <li>Ⓢ Provide a monitoring device for the hazardous materials storage system, or</li> <li>Ⓢ Maintain a visual monitoring log, or</li> <li>Ⓢ Begin performing inspections and documenting the results of the inspections.</li> </ul>
301	<b>Securing</b>	<ul style="list-style-type: none"> <li>Ⓢ Failure to secure the storage system.</li> <li>Ⓢ Secure hazardous materials storage area from public access.</li> </ul>
302	<b>Inspection Records</b>	<ul style="list-style-type: none"> <li>Ⓡ Failure to maintain inspection records for three years.</li> <li>Ⓢ Maintain all monitoring/inspections records for a minimum of three years.</li> </ul>
303	<b>Limit Controls</b>	Liquid level, temperature and pressure limit controls shall be provided for hazardous materials storage, use and dispensing systems.

### IV. Typical Storage Violations

No.	General type	Description
401	<b>704 Placarding</b>	<ul style="list-style-type: none"> <li>Ⓡ Failure to provide 704 placarding or labeling in accordance with Uniform Marking Guidelines.</li> <li>Ⓢ Provide 704 placarding and comply with Uniform Marking Guidelines</li> </ul>
402	<b>Oil Spill</b>	<ul style="list-style-type: none"> <li>Ⓡ Unauthorized discharge.</li> <li>Ⓢ Petroleum products and other hazardous materials shall not be discharged to the ground. (Oil spills are not permitted.)</li> </ul>
403	<b>Cabinets</b>	<ul style="list-style-type: none"> <li>Ⓡ Flammable liquids not stored in cabinet</li> <li>Ⓢ Provide approved flammable liquid cabinet for all class I, II, and III-A liquids over 10 gal.</li> </ul>
404	<b>Electrical Rooms</b>	<ul style="list-style-type: none"> <li>Ⓡ Hazardous materials stored in boiler, mechanical, or electrical room(s).</li> <li>Ⓢ No storage in boiler, mechanical, or electrical rooms.</li> </ul>
405	<b>Heating Unit</b>	<ul style="list-style-type: none"> <li>Ⓡ Hazardous materials stored too near heating unit.</li> <li>Ⓢ No storage within three feet of any heating unit.</li> </ul>
406	<b>Gas Cylinders Restraints</b>	<ul style="list-style-type: none"> <li>Ⓡ Compressed gas cylinder(s) not secured to a wall or other fixed object.</li> <li>Ⓢ All compressed gas cylinders must be secured with one or more non-combustible restraints to prevent falling.</li> </ul>
407	<b>Under Stairs</b>	<ul style="list-style-type: none"> <li>Ⓡ Hazardous materials stored under stairs.</li> <li>Ⓢ Storage under stairs shall not be permitted unless space is protected or enclosed by one hour wall.</li> </ul>
408	<b>Automatic Sprinkler Clearance</b>	<ul style="list-style-type: none"> <li>Ⓡ Hazardous materials stored too close to automatic sprinkler heads. Maintain an 18-inch clearance below automatic sprinklers, 24 inches below ceiling in non-sprinkled buildings.</li> <li>Ⓢ</li> </ul>
409	<b>Riser Clearance</b>	<ul style="list-style-type: none"> <li>Ⓡ Hazardous materials stored too near sprinkler riser. Maintain</li> <li>Ⓢ 3-foot clearance from Sprinkler riser.</li> </ul>

No.	General type	Description
410	<b>Fume Hood</b>	<ul style="list-style-type: none"> <li>Ⓡ Failure to provide automatic fire-extinguishing system for Laboratory fume hoods and spray booths where flammable materials are used.</li> <li>Ⓢ Discontinue use of Laboratory fume hood/spray booth until an automatic fire extinguishing system is installed.</li> <li>Ⓢ Submit plans to install automatic fire-extinguishing system.</li> </ul>
411	<b>Outside Storage</b>	<ul style="list-style-type: none"> <li>Ⓡ Improper outside storage of hazardous materials.</li> <li>Ⓡ Hazardous materials stored where spills could enter a storm drain.</li> <li>Ⓢ Outside storage shall be no higher than 20 ft. and 3 ft. from any wall or fence.</li> <li>Ⓢ Exterior storage of hazardous materials shall not be within 20 feet of any building, property line, street, alley, public way or exit to a public way.</li> <li>Ⓢ Storage areas shall be designed to prevent spills from discharging to a storm drain.</li> </ul>
412	<b>Piping</b>	<ul style="list-style-type: none"> <li>Ⓡ Piping installed without a permit.</li> <li>Ⓢ Submit plans to obtain permit.</li> </ul>
413	<b>Piping Labels</b>	<ul style="list-style-type: none"> <li>Ⓡ Piping not labelled.</li> <li>Ⓢ Label piping and tubing to identify contents every 20 feet and at changes in direction.</li> </ul>
414	<b>Toxic &amp; Highly Toxic Piping</b>	<ul style="list-style-type: none"> <li>Ⓡ Piping does not meet code requirements.</li> <li>Ⓢ Submit plans for upgrade.</li> </ul>
415	<b>Guard Posts</b>	<ul style="list-style-type: none"> <li>Ⓡ Inadequate or missing Guard posts.</li> <li>Ⓢ Guard posts or other means shall be provided to protect exterior dispensing or use areas from vehicular damage.</li> </ul>
416	<b>Non-combustible Floor</b>	<ul style="list-style-type: none"> <li>Ⓡ Improper floor construction.</li> <li>Ⓢ Submit plans to upgrade floor.</li> </ul>
417	<b>Liquid Tight Floors</b>	<ul style="list-style-type: none"> <li>Ⓡ Floor not liquid-tight.</li> <li>Ⓢ Submit plans to line or upgrade floor.</li> </ul>
418	<b>Cryogenic Storage</b>	<ul style="list-style-type: none"> <li>Ⓡ Improper interior storage of cryogenic tank.</li> <li>Ⓢ Submit plans for approved storage location.</li> </ul>
419	<b>Grounding/Bonding</b>	<ul style="list-style-type: none"> <li>Ⓡ Improper or missing grounding/bonding for flammable liquids dispensing.</li> <li>Ⓢ Discontinue dispensing until adequate grounding/bonding is provided.</li> </ul>
420	<b>MSDS</b>	<ul style="list-style-type: none"> <li>Ⓡ Failure to provide material safety data sheet (MSDS).</li> <li>Ⓢ The material safety data sheet (MSDS) shall be readily available for all Hazardous Materials on site.</li> </ul>
421	<b>Security</b>	<ul style="list-style-type: none"> <li>Ⓡ Failure to secure the storage area or system from unauthorized access.</li> <li>Ⓢ The storage of hazardous materials shall be safeguarded with such protective facilities as public safety requires.</li> </ul>
422	<b>Ignition</b>	<ul style="list-style-type: none"> <li>Ⓡ Failure to restrict smoking in rooms where hazardous materials are stored or within 25 feet of outdoor storage areas.</li> <li>Ⓢ Smoking shall be prohibited in rooms where hazardous materials are stored or within 25 feet of outdoor storage areas.</li> <li>Ⓢ Open-flame and other heat-producing equipment shall be located a safe distance from areas where temperature sensitive materials, flammable materials and compressed gases are dispensed, used or handled.</li> </ul>

No.	General type	Description
423	<b>Light Sensitive</b>	<ul style="list-style-type: none"> <li>⦿ Failure to store light sensitive materials in containers designed to protect them for exposure to light.</li> <li>Ⓢ Materials which are sensitive to light shall be stored in containers designed to protect them from such exposure.</li> </ul>
424	<b>Mechanical Ventilation</b>	<ul style="list-style-type: none"> <li>⦿ Inadequate ventilation for indoor hazardous materials storage areas and storage buildings.</li> <li>Ⓢ Indoor hazardous materials storage areas and storage buildings shall be provided with mechanical exhaust ventilation.</li> </ul>
425	<b>Emergency Alarm System</b>	<ul style="list-style-type: none"> <li>⦿ Failure to provide an emergency alarm system for hazardous materials.</li> <li>Ⓢ Submit plans to install an emergency alarm system.</li> </ul>
426	<b>Waterproof Room</b>	<ul style="list-style-type: none"> <li>⦿ Improper storage of water-reactive solids or liquids.</li> <li>Ⓢ Submit plans to upgrade the room or storage area.</li> </ul>
427	<b>Exhaust Scrubber</b>	<ul style="list-style-type: none"> <li>⦿ Failure to maintain exhaust scrubber.</li> <li>Ⓢ Exhaust scrubbers or other systems for the processing of highly toxic liquid vapors or gases shall be properly maintained and serviced at least annually.</li> </ul>
428	<b>Defective Containers</b>	<ul style="list-style-type: none"> <li>⦿ Defective container, cylinder or tank.</li> <li>Ⓢ Defective containers, cylinders and tanks shall be removed from service, repaired or disposed of in an approved manner.</li> </ul>
429	<b>Static Accumulation</b>	<ul style="list-style-type: none"> <li>⦿ Static electricity danger.</li> <li>Ⓢ When process or conditions exist where flammable mixture could be ignited by static electricity, means shall be provided to prevent the accumulation of a static charge.</li> </ul>
430	<b>Dispensing</b>	<ul style="list-style-type: none"> <li>⦿ Improper dispensing of hazardous materials from tank or drum.</li> <li>Ⓢ When liquids having a hazard ranking of 3 or 4 are dispensed from tanks or drums, dispensing shall be only by approved pumps taking suction from the top.</li> <li>Ⓢ When gases, liquids or solids having a hazard ranking of 3 or 4 are dispensed or used, mechanical exhaust ventilation shall be provided to capture fumes, mists or vapors at the point of generation.</li> <li>Ⓢ When liquids having a hazard ranking of 3 or 4 in accordance with U.F.C. Standard 79-3 are dispensed from tanks or drums, dispensing shall be only by approved pumps taking suction from the top.</li> </ul>
431	<b>Labeling</b>	<ul style="list-style-type: none"> <li>⦿ Containers inadequately labeled.</li> <li>Ⓢ Provide proper labels for all containers.</li> </ul>
432	<b>Flammable Liquids</b>	<ul style="list-style-type: none"> <li>⦿ Flammable liquids not stored in appropriate safety containers or cabinets.</li> <li>Ⓢ Provide approved containers and cabinets for storing flammable liquids.</li> </ul>

## V. Typical Emergency Response Violations

No.	General type	Description
550	<b>ER Equipment</b>	<ul style="list-style-type: none"> <li>⦿ Failure to test and maintain emergency equipment, or</li> <li>⦿ Absence of emergency equipment specified in Hazardous Materials Business Plan (HMBP) or Emergency Contingency Plan (ECP).</li> <li>Ⓢ Perform necessary tests and maintenance of all emergency equipment.</li> <li>Ⓢ Provide proper emergency equipment or modify HMBP or ECP.</li> </ul>
551	<b>ER Procedures</b>	<ul style="list-style-type: none"> <li>⦿ Failure to post emergency procedures.</li> <li>Ⓢ Post emergency procedures in an easily accessible location.</li> </ul>

No.	General type	Description
552	<b>ER Plan</b>	<ul style="list-style-type: none"> <li>⦿ Failure to prepare an emergency response plan and emergency procedures in the event of an emergency.</li> <li>Ⓢ Prepare and maintain an emergency response plan on-site. Note, this is a required component of the Hazardous Materials Business Plan.</li> </ul>
553	<b>Training</b>	<ul style="list-style-type: none"> <li>⦿ Failure to document annual training for all new employees, including refresher training, for all employees in safety procedures.</li> <li>Ⓢ Provide and document emergency and safety training for all employees.</li> </ul>
554	<b>Reportable Discharge</b>	<ul style="list-style-type: none"> <li>⦿ Failure to report an unauthorized hazardous materials discharge to the Fire Department.</li> <li>Ⓢ Prepare and submit a report to the Fire Department explaining the cause of the discharge and how future discharges will be prevented.</li> </ul>
555	<b>Recordable Discharge</b>	<ul style="list-style-type: none"> <li>⦿ Failure to document a recordable unauthorized hazardous materials discharge.</li> <li>Ⓢ Begin documenting all unauthorized recordable discharges.</li> </ul>
556	<b>Corrective Action</b>	<ul style="list-style-type: none"> <li>⦿ Failure to implement all actions necessary to remedy the effects of an unauthorized discharge.</li> <li>Ⓢ Develop plan and implement proposed remediation actions to prevent future discharges.</li> </ul>

## WASTE MANAGEMENT

### Typical Fire Safety Inspection Violations

The following is a list of typical violations often found by inspectors and a generic solution. You can use this list to improve the safety of your facility, to prepare for an upcoming inspection, or to develop your own self inspection program. Note that specific code requirements may vary somewhat from jurisdiction to jurisdiction, so if you have questions or would like to know the specific code sections, please contact your local agency. (The reference number is used to make it easier to identify specific items; it does not refer to a code or ordinance.)

#### I. Typical Extinguisher Violations

No.	General type	Description
150	<b>Extinguishers</b>	<ul style="list-style-type: none"> <li>Ⓡ Insufficient number of fire extinguishers.</li> <li>Ⓢ Provide xx number of fire extinguishers.</li> </ul>
151	<b>Extinguisher Servicing</b>	<ul style="list-style-type: none"> <li>Ⓡ Fire Extinguisher not serviced within last 12 months.</li> <li>Ⓢ Provide annual servicing for all fire extinguishers.</li> </ul>
152	<b>Welding Cart</b>	<ul style="list-style-type: none"> <li>Ⓡ Welding cart does not have a fire extinguisher.</li> <li>Ⓢ Provide extinguisher for welding and cutting on or near the oxygen acetylene rack.</li> </ul>
153	<b>Fixed Fire System Service</b>	<ul style="list-style-type: none"> <li>Ⓡ Failure to service system.</li> <li>Ⓢ Service fixed system every 6 months or after activation</li> </ul>
154	<b>Portable Fire System Service</b>	<ul style="list-style-type: none"> <li>Ⓡ Failure to service extinguisher(s).</li> <li>Ⓢ Service fire extinguisher annually or after use.</li> </ul>
155	<b>Spray Booths</b>	<ul style="list-style-type: none"> <li>Ⓡ Spray booth or spray room unprotected by an approved automatic fire extinguisher system.</li> <li>Ⓢ Submit plans to install an approved automatic fire extinguisher system.</li> </ul>
156	<b>Spray Booth Residue</b>	<ul style="list-style-type: none"> <li>Ⓡ Combustible residue buildup in spraying area.</li> <li>Ⓢ Remove and properly dispose of combustible residue. Maintain spraying area clean and free from residue buildup.</li> </ul>
157	<b>Spray Paint Shut Off Valve</b>	<ul style="list-style-type: none"> <li>Ⓡ Missing shut off valve.</li> <li>Ⓢ Provide shut off valve between paint container and piping.</li> </ul>
158	<b>Fume Hoods</b>	<ul style="list-style-type: none"> <li>Ⓡ Laboratory fume hoods and spray booths where flammable or hazardous materials are used unprotected by an automatic fire-extinguishing system.</li> <li>Ⓢ Submit plans to install an approved automatic fire extinguisher system.</li> </ul>
159	<b>5-Yr Test</b>	<ul style="list-style-type: none"> <li>Ⓡ Failure to provide an automatic sprinkler system in all interior and exterior storage areas, and gas cabinets (see Cabinets on page 259).</li> <li>Ⓢ Submit plans to provide an automatic sprinkler system.</li> </ul>
160	<b>Fire Extinguishing Systems</b>	<ul style="list-style-type: none"> <li>Ⓡ Indoor flammable or hazardous materials storage areas and storage buildings unprotected by an automatic fire sprinkler system.</li> <li>Ⓢ Submit plans to install an approved automatic fire extinguisher system.</li> </ul>
161	<b>Heated Plating Baths</b>	<ul style="list-style-type: none"> <li>Ⓡ Electroplating, electroless plating, or metal finishing operations using heated baths in unsprinklered buildings.</li> <li>Ⓢ Submit plans to install an approved fire suppression system</li> </ul>

## II. Typical Electrical Violations

No.	General type	Description
250	<b>Cover Plates</b>	<ul style="list-style-type: none"> <li>Ⓡ Exposed cover plates on electrical junction boxes.</li> <li>Ⓢ Replace cover plates on electrical boxes.</li> </ul>
251	<b>Zip Wiring</b>	<ul style="list-style-type: none"> <li>Ⓡ Zip wiring, extension cords, and/or exposed romex wiring observed.</li> <li>Ⓢ All permanent wiring must be in conduit and installed in accordance with the Electric Code. Fusible power strips are acceptable for some situations.</li> </ul>
252	<b>Multi-Plugs</b>	<ul style="list-style-type: none"> <li>Ⓡ Multi-plug adapters observed in lieu of permanent wiring.</li> <li>Ⓢ Multi-plug adapters may be used in temporary installations only.</li> </ul>
253	<b>Clearance</b>	<ul style="list-style-type: none"> <li>Ⓡ Electrical control panel door blocked or obstructed.</li> <li>Ⓢ Minimum 30 in. clearance in front of electrical control panel.</li> </ul>
254	<b>Motors</b>	<ul style="list-style-type: none"> <li>Ⓡ Electrical motor covered with oil, dirt, or other materials.</li> <li>Ⓢ All electrical motors shall be maintained free of oil, dirt, waste, etc.</li> </ul>
255	<b>Wiring</b>	<ul style="list-style-type: none"> <li>Ⓡ Improper wiring observed.</li> <li>Ⓢ Electrical wiring and equipment shall be installed in accordance with the Electrical Code.</li> </ul>
256	<b>Standby Power</b>	<ul style="list-style-type: none"> <li>Ⓡ Standby power not provided or of insufficient capacity.</li> <li>Ⓢ Mechanical ventilation, treatment systems, temperature control, alarms, detection systems shall be connected to a secondary source of power to automatically supply electrical power in the event of loss of power.</li> </ul>
257	<b>Limit Controls</b>	<ul style="list-style-type: none"> <li>Ⓡ Appropriate limit controls absent or malfunctioning.</li> <li>Ⓢ Liquid level, temperature and pressure limit controls shall be provided and maintained for hazardous materials storage, use and dispensing systems.</li> </ul>

## III. Typical Exit Violations

No.	General type	Description
300	<b>Obstructions</b>	<ul style="list-style-type: none"> <li>Ⓡ Blocked, locked, or obstructed exits observed</li> <li>Ⓢ Exits shall be clear of storage or obstructions. Exits shall not be blocked.</li> </ul>
301	<b>Aisles</b>	<ul style="list-style-type: none"> <li>Ⓡ Proper aisles not provided.</li> <li>Ⓢ Aisle(s) leading to required exits shall be approved and provided for all portions of the building.</li> </ul>
302	<b>Exit Doors</b>	<ul style="list-style-type: none"> <li>Ⓡ Improper latching devices on exit door(s).</li> <li>Ⓢ Exit door(s) shall open from the inside without use of key or special knowledge or effort.</li> </ul>
303	<b>Self-Closing Doors</b>	<ul style="list-style-type: none"> <li>Ⓡ Self-closing door blocked or obstructed.</li> <li>Ⓢ Remove obstructions or repair self-closing door(s).</li> </ul>
304	<b>Horizontal Exit</b>	<ul style="list-style-type: none"> <li>Ⓡ Insufficient number of exits for building or portion of building.</li> <li>Ⓢ A horizontal exit shall not serve as the only exit from a portion of a building when two or more exits are required.</li> </ul>
305	<b>Second Exits</b>	<ul style="list-style-type: none"> <li>Ⓡ Only one exit observed.</li> <li>Ⓢ Second exits in garages required if over 1000 sq. ft.</li> </ul>
306	<b>Identification</b>	<ul style="list-style-type: none"> <li>Ⓡ No visible exit signs.</li> <li>Ⓢ Exit door identification shall be visible.</li> </ul>
307	<b>44-Inch Aisles</b>	<ul style="list-style-type: none"> <li>Ⓡ Aisles too narrow or obstructed.</li> <li>Ⓢ Maintain minimum 44-inch aisle way to exits.</li> </ul>



#### IV. Typical Storage Violations

No.	General type	Description
400	<b>Fire Hazard</b>	<ul style="list-style-type: none"> <li>⦿ Combustible materials stored improperly.</li> <li>Ⓢ Remove materials causing a fire hazard.</li> </ul>
401	<b>Oil Spill</b>	<ul style="list-style-type: none"> <li>⦿ Oil spilled on ground or floor.</li> <li>Ⓢ Clean and properly dispose of all spilled materials.</li> </ul>
402	<b>Vehicle Parts</b>	<ul style="list-style-type: none"> <li>⦿ Improper location of motor vehicles or parts.</li> <li>Ⓢ Motor vehicles or any part thereof, junk or other waste material shall not be stored or kept in such a manner to hinder or endanger firefighting operations.</li> </ul>
403	<b>Rubbish</b>	<ul style="list-style-type: none"> <li>⦿ Poor housekeeping.</li> <li>Ⓢ Accumulations of waste, combustible, or flammable rubbish shall not be permitted to remain in any court, yard, vacant lot, or open space.</li> </ul>
404	<b>Cabinets</b>	<ul style="list-style-type: none"> <li>⦿ Improper cabinets and/or cabinet doors not self-closing and self-latching.</li> <li>Ⓢ Provide approved flammable liquid cabinet for all class I, II, and III-A liquids over 10 gal. Cabinets must be self-closing and self-latching.</li> </ul>
405	<b>Electrical Rooms</b>	<ul style="list-style-type: none"> <li>⦿ Materials observed stored in boiler, mechanical, or electrical room.</li> <li>Ⓢ No storage in boiler, mechanical, or electrical rooms.</li> </ul>
406	<b>Heating Unit</b>	<ul style="list-style-type: none"> <li>⦿ Materials observed stored adjacent to heating unit.</li> <li>Ⓢ No storage within three feet of any heating unit.</li> </ul>
407	<b>Passageways</b>	<ul style="list-style-type: none"> <li>⦿ Aisles and passageways blocked or too narrow.</li> <li>Ⓢ Aisles and passageways shall be provided to allow reasonable access for Firefighting operations.</li> </ul>
408	<b>Gas Cylinders</b>	<ul style="list-style-type: none"> <li>⦿ Gas cylinders observed without proper securing.</li> <li>Ⓢ All compressed gas cylinders must be secured to prevent falling with noncombustible restraints. Cylinders over 26 inches in height must have two restraints as close as practical to 1/3 and 2/3 of the cylinder's height.</li> </ul>
409	<b>Metal Cans</b>	<ul style="list-style-type: none"> <li>⦿ Oily rags observed collecting in an open container.</li> <li>Ⓢ All combustible rubbish (oily rags) shall be stored in metal cans with tight lids.</li> </ul>
410	<b>Under Stairs</b>	<ul style="list-style-type: none"> <li>⦿ Combustible materials observed under stairs.</li> <li>Ⓢ Storage under stairs shall not be permitted unless space is protected or enclosed by one hour wall.</li> </ul>
411	<b>Automatic Sprinkler Clearance</b>	<ul style="list-style-type: none"> <li>⦿ Materials stored too close to sprinkler heads or ceiling.</li> <li>Ⓢ Maintain an 18-inch clearance below automatic sprinklers, 24 inches below ceiling in non-sprinkled buildings.</li> </ul>
412	<b>Riser Clearance</b>	<ul style="list-style-type: none"> <li>⦿ Materials stored too close to riser.</li> <li>Ⓢ Maintain 3-foot clearance from Sprinkler riser.</li> </ul>
413	<b>Outside Storage / Control Areas</b>	<ul style="list-style-type: none"> <li>⦿ Improper outside storage.</li> <li>Ⓢ Outside storage shall be no higher than 20 ft. and at least 3 ft. from any wall or fence.</li> <li>Ⓢ Exterior storage of flammable solids shall not be within 20 feet of any building, property line, street, alley, public way or exit to a public way.</li> <li>Ⓢ Exterior storage of toxic or highly toxic solids and liquids shall not be within 20 feet of buildings, property lines, streets, alleys, public ways or exits to a public way.</li> <li>Ⓢ Exterior storage of corrosive liquids shall not be within 20 feet of buildings, property lines, streets, alleys, public ways or exits to a public way.</li> </ul>

No.	General type	Description
414	<b>Attic Clearance</b>	<ul style="list-style-type: none"> <li>⦿ Combustible materials observed in attic area.</li> <li>Ⓢ Keep attics clear of combustible materials.</li> </ul>
415	<b>Spray Areas</b>	<ul style="list-style-type: none"> <li>⦿ Combustible residue buildup in spray area.</li> <li>Ⓢ Clean spray areas and maintain free from combustible residue buildup.</li> </ul>
416	<b>Spray Paint Dispensing</b>	<ul style="list-style-type: none"> <li>⦿ No shut off valve provided between container and dispensing piping/tubing.</li> <li>Ⓢ Provide shut off valve.</li> </ul>
417	<b>Guard Posts</b>	<ul style="list-style-type: none"> <li>⦿ Insufficient protection from vehicles.</li> <li>Ⓢ Guard posts or other means shall be provided to protect exterior storage tanks from vehicular damage. When guard posts are installed, they shall be: <ul style="list-style-type: none"> <li>• Constructed of steel not less than 4 inches in diameter and concrete filled,</li> <li>• Spaced not more than 4 feet between posts on center,</li> <li>• Set not less than 3 feet deep in a concrete footing not less than 15 inches in diameter,</li> <li>• Set with the top of the posts not less than 3 feet above ground, and</li> <li>• Located not less than 5 feet from the tank.</li> </ul> </li> <li>Ⓢ Guard posts or other means shall be provided to protect exterior dispensing or use areas from vehicular damage.</li> </ul>
418	<b>Combustible Clearance</b>	<ul style="list-style-type: none"> <li>⦿ Combustible materials collected or stored near</li> <li>Ⓢ The area surrounding an exterior storage/dispensing or use area, or tank shall be kept clear of combustible materials and vegetation for a minimum distance of 30 feet.</li> </ul>
419	<b>Cryogenic Storage</b>	<ul style="list-style-type: none"> <li>⦿ Cylinder of cryogenic materials exceeding 1000 pounds water capacity observed inside building.</li> <li>Ⓢ Cryogenic fluids in individual cylinders, containers or tanks which exceed a water capacity of 1,000 pounds shall not be stored inside of buildings.</li> </ul>

#### V. Typical Miscellaneous Response Violations

No.	General type	Description
550	<b>704 Placarding</b>	<ul style="list-style-type: none"> <li>⦿ Inadequate placarding provided for building, room, or tank.</li> <li>Ⓢ Provide 704 placarding.</li> </ul>
551	<b>Addresses</b>	<ul style="list-style-type: none"> <li>⦿ Address missing, numbers are too small or placed where they are not visible from street.</li> <li>Ⓢ Approved numbers or addresses shall be placed on all new and existing buildings.</li> </ul>
552	<b>Holes in Walls</b>	<ul style="list-style-type: none"> <li>⦿ Holes observed in walls of building or room.</li> <li>Ⓢ Holes in walls and all fire resistive construction shall be repaired and maintained.</li> </ul>
553	<b>Room Capacity</b>	<ul style="list-style-type: none"> <li>⦿ Room capacity signs missing or wrong.</li> <li>Ⓢ Posting of room capacity is required in rooms w/o fixed seating and used as classroom, Assembly Room, or similar use where capacity exceeds 49.</li> </ul>
554	<b>Apparatus Access</b>	<ul style="list-style-type: none"> <li>⦿ Fire access too restricted or obstructed by vehicles or equipment.</li> <li>Ⓢ Provide a fire apparatus access road minimum 26 feet clear width curb to curb, and 14 feet vertical clearance front to back.</li> </ul>
555	<b>Grounding/Bonding</b>	<ul style="list-style-type: none"> <li>⦿ Inadequate bonding and or grounding for flammable and combustible materials dispensing.</li> <li>Ⓢ When class I and II liquids are dispensed, adequate grounding and bonding shall be provided to prevent static electricity.</li> </ul>

No.	General type	Description
556	<b>Woodworking Shops</b>	<ul style="list-style-type: none"> <li>⦿ Wood dust has accumulated and created a fire hazard.</li> <li>Ⓢ Woodworking plants shall be equipped with refuse removal system which will collect and remove sawdust and shavings produced.</li> </ul>
557	<b>Ignition</b>	<ul style="list-style-type: none"> <li>⦿ Personnel observed smoking in unsafe areas.</li> <li>Ⓢ Smoking shall be prohibited in rooms where hazardous materials are stored or within 25 feet of outdoor storage areas.</li> <li>Ⓢ Open-flame and other heat-producing equipment shall be located a safe distance from areas where temperature sensitive materials, flammable materials and compressed gases are dispensed, used or handled.</li> </ul>
558	<b>Mechanical Ventilation</b>	<ul style="list-style-type: none"> <li>⦿ Inadequate ventilation for building or storage area.</li> <li>Ⓢ Indoor storage areas and storage buildings shall be provided with mechanical exhaust ventilation.</li> </ul>
559	<b>Venting</b>	<ul style="list-style-type: none"> <li>⦿ No smoke or heat ventilation provided.</li> <li>Ⓢ Smoke and heat venting shall be provided.</li> </ul>
560	<b>Dispensing</b>	<ul style="list-style-type: none"> <li>⦿ Improper dispensing of flammable and combustible materials.</li> <li>Ⓢ When liquids having a hazard ranking of 3 or 4 are dispensed from tanks or drums, dispensing shall be only by approved pumps taking suction from the top.</li> <li>Ⓢ When gases, liquids or solids having a hazard ranking of 3 or 4 are dispensed or used, mechanical exhaust ventilation shall be provided to capture fumes, mists or vapors at the point of generation.</li> <li>Ⓢ When liquids having a hazard ranking of 3 or 4 in accordance with U.F.C. Standard 79-3 are dispensed from tanks or drums, dispensing shall be only by approved pumps taking suction from the top.</li> </ul>
561	<b>Heated Plating Baths</b>	<ul style="list-style-type: none"> <li>⦿ Failure to provide fire protection for heated plating or metal finishing baths.</li> <li>Ⓢ Submit plans to install an approved fire sprinkler system for the building or discontinue use of heating elements for plating or metal finishing baths.</li> </ul>

## WASTE MANAGEMENT

### Solid Waste Management

#### Benefits of a Waste Reduction Program

The following is a list and explanation of the benefits of waste reduction.

##### 1. More Efficient Operations and Reduced Costs

Through reduction of waste, the factory improves its efficiency. By practicing waste reduction, the company will purchase, use and throw away less due to cost-effective management. In addition to reduction of raw material costs, office supply expenses and equipment purchases, waste reduction practices will lower solid waste disposal and service costs while potentially generating revenue from recyclable materials. As land for landfills becomes scarcer, disposal costs will increase; by lowering waste production these increased costs can be minimized.

##### 2. Environmental Protection

An extremely important benefit to waste reduction is the protection of the environment. Through these efforts, fewer natural resources are used, pollution caused by extraction and is avoided, and landfill space is conserved.

##### 3. Enhanced Public Image

Waste reduction demonstrates an innovative and forward-thinking approach to environmental management. These efforts display a strong business sense for an environmentally-conscious society. Attempts such as waste reduction programs also show the factory's willingness to comply with legislation.

##### 4. Improved Worker Morale

Often overlooked, a waste reduction program is based on the "buy-in" of the workers. These guidelines give workers an opportunity to participate and help the company save resources and money.

#### Food Waste Minimization

##### General Tips:

- Buy products in bulk to minimize the amount of packaging. However, try to avoid waste through spoilage by purchasing only what you need.
- Examine the possibility of composting all leftover and off-spec food waste. This can be accomplished by purchasing an in-vessel or standard composter,

or giving the produce waste to staff to place in their home units. Use finished compost on-site or give it to staff or others who may be interested (e.g. customers, local nurseries). If this is not feasible, investigate local markets such as farmers or centralized composting

- facilities (contact local municipality for a list of viable markets).
- Purchase products in refillable, reusable or recyclable containers, and ask your suppliers to take back containers.
  - Ensure staff members are aware of and familiar with all company waste reduction programs, policies and objectives. Keep them informed. Set up a staff waste reduction committee.

**Kitchen:**

- Set up a system to collect all grease, fat, and possibly meat and bone scraps. Then contract with a rendering facility to pick up the materials for use in the manufacturing of animal feed and tallow.

**Office Supplies Minimization**

The centerpiece of recycling in office areas is office paper. Every effort should be made to recycle all forms of paper within the production facility. Most types of paper are recyclable including computer printout (colored or blank), white ledger, colored ledger, manila folders, pamphlets, brochures, phone books and newspapers. Paper around the factory that currently cannot be recycled includes glossy paper, paper with food contamination, and blueprint.

**Office Paper:**

- Use single-spaced format for the text of documents.
- Print only what is needed.
- Use electronic mail for sending and receiving business messages rather than printed memos.
- Set copiers to print double-sided photocopies automatically.
- Re-use scrap paper (with printing on one-side) for printing drafts, as scrap paper and/or office note pads.
- Recycle paper that cannot be re-used.
- Provide dedicated recycling containers for paper to be recycled to avoid contaminating paper with food.
- Purchase recycled paper in the office.

- Prepare and cook only what is needed.
- Sell or give leftover food to staff or food banks.
- Purchase reusable coffee filters.

**Dining Room:**

- Offer smaller portions at a reduced price for those who want them.
- Discourage the use of straws, paper napkins, and disposable stirring sticks.
- Provide bulk, refillable containers for cream, sugar, ketchup, mustard, and salt and pepper.
- Use cleaning rags, not paper towels.
- Use linen tablecloths and napkins in place of disposable ones.

**Supplies:**

- Reduce the quantity of supplies that are purchased and maintained on hand.
- Purchase pens and pencils that can be refilled
- Re-use items such as paper clips and rubber bands
- Obtain printer and photocopier cartridges from companies that offer recycling programs, whenever possible.

**Preventing Storm Water Pollution**

Best Management Practices are general (i.e., not operation-specific) measures designed to control, prevent, or minimize exposure of potentially polluting materials to storm water in potential contact zones (such as material- handling areas, loading/ unloading areas, etc.).

**Good Housekeeping**

- Good housekeeping practices are designed to maintain a neat, clean, and orderly factory. These are primarily measures to eliminate or reduce exposure of waste materials to precipitation runoff prior to disposal. These practices, when implemented on a routine basis during the course of work activities, minimize storm water contact with potentially polluting materials. Good housekeeping practices at the factory should include the following:
  - Regular sweeping of the potential contact zone areas (e.g., trash dumpsters, materials storage and handling areas, loading docks and outdoor processing areas)
  - Regular removal of garbage, trash, unusable equipment, and waste material from the factory grounds
  - Storing materials away from direct traffic routes and in a manner that provides space for vehicles to maneuver
  - Controlling material inventories to reduce quantities of materials stored and handled
  - Routine inspection of potential contact zone areas for leaks or conditions that could lead to discharges of chemicals or fluids
  - Taking immediate action in the event a significant spill or release is detected, in accordance with established procedures
  - Properly labeling material packages and containers to show the type and name of material or substance
  - Staging, storing, or handling materials in areas that discharge to the wastewater treatment factory and not to the storm water drainage system
  - Maintaining closed lids on dumpsters, other waste containers, and chemical storage containers, whenever practicable
  - Maintaining dumpsters and other waste containers in good condition

**Preventive Maintenance**

- Preventive maintenance should be conducted on structural controls, factory equipment, and vehicles to minimize the potential for materials associated with their operation and maintenance to contact storm water. Preventive maintenance measures at the factory should include the following:
  - Routinely cleaning out catch basins, containments, and control structures

- Routinely inspecting machinery, equipment, and vehicles used in potential contact zone areas (primarily forklifts) for indications of potential mechanical failures or fluid leakage
- Routinely inspecting/evaluating/replacing connections, valves, transfer lines, and pipes that carry chemicals and wastes
- Reporting leaks or potential problems to the appropriate supervisors and promptly scheduling repairs
- Ensuring equipment is kept well-maintained and in good service

### Spill Prevention and Response

The occurrence of spills at the factory should be minimized through proper training of factory personnel, routine inspection and preventive maintenance of factory equipment, and implementation of other best management practices. These practices include the requirement for drums, tanks, and other containers of chemicals to be stored in protected areas, away from drains, and to be clearly labeled. In addition, hazardous waste containers should be clearly marked to identify contents, storage dates, and special handling and disposal requirements.

- Particular attention should be paid to the inspection and evaluation of piping systems that carry chemicals and wastes, and the timely repair or replacement of connections, valves, pipes, and appurtenances to prevent releases from these systems. This inspection and evaluation program consists of the following elements:
  - routine visual inspections of accessible pipes, connections, valves, utility holes, pits, filters, screens, and other parts of the factory's industrial laundry process wastewater transfer system that carries water from process areas to the on-site treatment system;
  - routine testing to ensure the proper function of controls, sensors, and alarms designed to monitor liquid levels, flow rates, and line pressures, and to alert factory personnel in the event of an upset condition; and
  - repair, upgrade, or replacement of any wastewater transfer system components observed to be leaking, deteriorated, or otherwise deemed to represent a risk of future leaks or spills (e.g., cracked pipes or valve bodies).

Arrangements may be made with an outside contractor to respond to and remediate hazardous waste spills and significant spills involving non-hazardous substances that cannot be managed solely by factory Spill Response personnel.

Spill kits containing response materials such as absorbent pads, goggles, safety gloves, protective clothing, brooms, and vacuums, should be maintained in accessible locations within or near the potential contact zone.

### Inspections

Routine inspections of each potential contact zone should be a part of daily work practices at the factory. The purpose of the routine inspections is to promptly identify and mitigate potential problems that could result in contact of significant materials by storm water.

Monthly inspections should ensure that appropriate materials handling practices are followed, specified best management practices are being implemented and are effective, required spill response equipment is maintained in a state of readiness, and factory equipment is maintained in good working condition. A Monthly Inspection Checklist (found at the end of this Appendix) should be used to document monthly inspections.

### Worker Education and Training

Workers whose jobs involve industrial activities with the potential to contact storm water should be trained to perform their work in a manner that prevents contamination of storm water by observing best management practices, such as:

- Good housekeeping and material management practices, including the proper management and disposal of solvents, other petroleum products, dyes, and other chemicals
- Spill prevention and response procedures
- The purpose and correct implementation of best management practices
- Monitoring and inspection requirements and procedures, including sample collection and handling protocols
- Record keeping and reporting requirements

In addition, all workers should receive general awareness training, including education on the need to maintain a clean and orderly factory.

### Sediment and Erosion Control

Sediment and erosion control measures should include paving and maintaining vegetative cover, mulch, or gravel in unpaved areas.

### Structural Improvements

Structural improvements may be used to manage storm water runoff. Examples include:

- Site grading to direct runoff away from buildings and to segregate runoff generated in areas where industrial activities are conducted (e.g., loading docks) from runoff generated in other site areas such as worker parking lots and office areas

- Structural controls, such as secondary containments in outdoor industrial areas, that allow storm water to be collected and transported to a wastewater treatment plant
- A curb-and-gutter system to capture runoff and direct flow to appropriate outfall locations
- Roofs installed over equipment and storage areas to prevent exposure to precipitation

Structural features such as these are effective in limiting the potential for industrial activities to adversely impact storm water quality.

### Record-Keeping

Copies of completed inspection forms, inventories of potentially polluting materials, spill histories, etc., should be retained on file for a minimum of 3 years.

### Spill Log

Instructions: This Spill Log should be updated quarterly to record all spills or leaks that occur at the factory in areas exposed to storm water, or document that no spill has taken place. If a spill or leak does occur during a quarter, indicate this by entering “ Yes” in the second column from left, and complete all other columns for the spill/leak incident. If no spills or leaks occur during a quarter, please indicate this by entering “ No” in the second column from left.

Year & Did spills or (Yes/No)	Incident Date (D/M/Y)	Location	Type of material	Spill Description Quantity spilled	Did spilled material discharge offsite? (yes/No)	Response Description Response and prevention measures taken & completion dates
Year						
Q1						
Q2						
Q3						
Q4						
Year						
Q1						
Q2						
Q3						
Q4						
Year						
Q1						
Q2						
Q3						
Q4						

Spill Response Materials

Located	Materials Description	Amount to be stocked Per	Check	Amount to be re-stocked	Check
Sample	Goggles, safety gloves, apron, and protective clothing. Face shield, broom, vacuum, mop, and absorbents.				
	(3) sets of goggles, safety gloves, apron, and protective clothing. (1) of each of the following: face shield, broom, vacuum, mop, and some				

**Storm Water: Monthly Inspection List**

**Instructions**

1. Complete inspection of each area in which there is the potential for contact between rainwater and hazardous materials. Indicate the area on the top row. N/A indicates that the inspection item is not applicable for the associated area.
2. Explain any failing results on page 2 of this form. Provide a list of required actions necessary to correct the failing result, including responsible personnel and completion dates.
3. Note any other comments or observations from the monthly inspection on next page.

Inspection Item :	Area inspected			Area inspected			Area inspected			Area inspected		
	Pass	Fail	N/A	Pass	Fail	N/A	Pass	Fail	N/A	Pass	Fail	N/A
Floor of storage areas is free of spilled material	<input type="checkbox"/>	<input type="checkbox"/>	<input type="checkbox"/>	<input type="checkbox"/>	<input type="checkbox"/>	<input type="checkbox"/>	<input type="checkbox"/>	<input type="checkbox"/>	<input type="checkbox"/>	<input type="checkbox"/>	<input type="checkbox"/>	<input type="checkbox"/>
No unusual odors	<input type="checkbox"/>	<input type="checkbox"/>	<input type="checkbox"/>	<input type="checkbox"/>	<input type="checkbox"/>	<input type="checkbox"/>	<input type="checkbox"/>	<input type="checkbox"/>	<input type="checkbox"/>	<input type="checkbox"/>	<input type="checkbox"/>	<input type="checkbox"/>
Ground is dry and free of debris or spilled material	<input type="checkbox"/>	<input type="checkbox"/>	<input type="checkbox"/>	<input type="checkbox"/>	<input type="checkbox"/>	<input type="checkbox"/>	<input type="checkbox"/>	<input type="checkbox"/>	<input type="checkbox"/>	<input type="checkbox"/>	<input type="checkbox"/>	<input type="checkbox"/>
Floor brooms and waste receptacles present / available	<input type="checkbox"/>	<input type="checkbox"/>	<input type="checkbox"/>	<input type="checkbox"/>	<input type="checkbox"/>	<input type="checkbox"/>	<input type="checkbox"/>	<input type="checkbox"/>	<input type="checkbox"/>	<input type="checkbox"/>	<input type="checkbox"/>	<input type="checkbox"/>
Waste receptacles normally closed and regularly emptied	<input type="checkbox"/>	<input type="checkbox"/>	<input type="checkbox"/>	<input type="checkbox"/>	<input type="checkbox"/>	<input type="checkbox"/>	<input type="checkbox"/>	<input type="checkbox"/>	<input type="checkbox"/>	<input type="checkbox"/>	<input type="checkbox"/>	<input type="checkbox"/>
Floor / ground free of equipment that should be shelved or otherwise stored	<input type="checkbox"/>	<input type="checkbox"/>	<input type="checkbox"/>	<input type="checkbox"/>	<input type="checkbox"/>	<input type="checkbox"/>	<input type="checkbox"/>	<input type="checkbox"/>	<input type="checkbox"/>	<input type="checkbox"/>	<input type="checkbox"/>	<input type="checkbox"/>
No significant leakage from stored vehicles or machinery	<input type="checkbox"/>	<input type="checkbox"/>	<input type="checkbox"/>	<input type="checkbox"/>	<input type="checkbox"/>	<input type="checkbox"/>	<input type="checkbox"/>	<input type="checkbox"/>	<input type="checkbox"/>	<input type="checkbox"/>	<input type="checkbox"/>	<input type="checkbox"/>
No leakage from drums, containers, tanks, piping, valves or connections	<input type="checkbox"/>	<input type="checkbox"/>	<input type="checkbox"/>	<input type="checkbox"/>	<input type="checkbox"/>	<input type="checkbox"/>	<input type="checkbox"/>	<input type="checkbox"/>	<input type="checkbox"/>	<input type="checkbox"/>	<input type="checkbox"/>	<input type="checkbox"/>
Pavement free of significant oil stains and debris	<input type="checkbox"/>	<input type="checkbox"/>	<input type="checkbox"/>	<input type="checkbox"/>	<input type="checkbox"/>	<input type="checkbox"/>	<input type="checkbox"/>	<input type="checkbox"/>	<input type="checkbox"/>	<input type="checkbox"/>	<input type="checkbox"/>	<input type="checkbox"/>
All chemical containers and containerized liquids are clearly labeled and stored away from drains	<input type="checkbox"/>	<input type="checkbox"/>	<input type="checkbox"/>	<input type="checkbox"/>	<input type="checkbox"/>	<input type="checkbox"/>	<input type="checkbox"/>	<input type="checkbox"/>	<input type="checkbox"/>	<input type="checkbox"/>	<input type="checkbox"/>	<input type="checkbox"/>
All materials packaged or non-friable	<input type="checkbox"/>	<input type="checkbox"/>	<input type="checkbox"/>	<input type="checkbox"/>	<input type="checkbox"/>	<input type="checkbox"/>	<input type="checkbox"/>	<input type="checkbox"/>	<input type="checkbox"/>	<input type="checkbox"/>	<input type="checkbox"/>	<input type="checkbox"/>

Inspection Item :	Area inspected			Area inspected			Area inspected			Area inspected		
	Pass	Fail	N/A	Pass	Fail	N/A	Pass	Fail	N/A	Pass	Fail	N/A
No storage of unauthorized equipment or materials	<input type="checkbox"/>	<input type="checkbox"/>	<input type="checkbox"/>	<input type="checkbox"/>	<input type="checkbox"/>	<input type="checkbox"/>	<input type="checkbox"/>	<input type="checkbox"/>	<input type="checkbox"/>	<input type="checkbox"/>	<input type="checkbox"/>	<input type="checkbox"/>
Area is free of spilled material	<input type="checkbox"/>	<input type="checkbox"/>	<input type="checkbox"/>	<input type="checkbox"/>	<input type="checkbox"/>	<input type="checkbox"/>	<input type="checkbox"/>	<input type="checkbox"/>	<input type="checkbox"/>	<input type="checkbox"/>	<input type="checkbox"/>	<input type="checkbox"/>
Spill Response materials available and fully stocked	<input type="checkbox"/>	<input type="checkbox"/>	<input type="checkbox"/>	<input type="checkbox"/>	<input type="checkbox"/>	<input type="checkbox"/>	<input type="checkbox"/>	<input type="checkbox"/>	<input type="checkbox"/>	<input type="checkbox"/>	<input type="checkbox"/>	<input type="checkbox"/>
Receptacle containment intact	<input type="checkbox"/>	<input type="checkbox"/>	<input type="checkbox"/>	<input type="checkbox"/>	<input type="checkbox"/>	<input type="checkbox"/>	<input type="checkbox"/>	<input type="checkbox"/>	<input type="checkbox"/>	<input type="checkbox"/>	<input type="checkbox"/>	<input type="checkbox"/>
Dumpster lid is closed	<input type="checkbox"/>	<input type="checkbox"/>	<input type="checkbox"/>	<input type="checkbox"/>	<input type="checkbox"/>	<input type="checkbox"/>	<input type="checkbox"/>	<input type="checkbox"/>	<input type="checkbox"/>	<input type="checkbox"/>	<input type="checkbox"/>	<input type="checkbox"/>
No leakage from dumpster	<input type="checkbox"/>	<input type="checkbox"/>	<input type="checkbox"/>	<input type="checkbox"/>	<input type="checkbox"/>	<input type="checkbox"/>	<input type="checkbox"/>	<input type="checkbox"/>	<input type="checkbox"/>	<input type="checkbox"/>	<input type="checkbox"/>	<input type="checkbox"/>
Area is free of significant erosion or sedimentation	<input type="checkbox"/>	<input type="checkbox"/>	<input type="checkbox"/>	<input type="checkbox"/>	<input type="checkbox"/>	<input type="checkbox"/>	<input type="checkbox"/>	<input type="checkbox"/>	<input type="checkbox"/>	<input type="checkbox"/>	<input type="checkbox"/>	<input type="checkbox"/>
Structural controls are intact and free of debris (curbs, gutters, catch basins, etc.)	<input type="checkbox"/>	<input type="checkbox"/>	<input type="checkbox"/>	<input type="checkbox"/>	<input type="checkbox"/>	<input type="checkbox"/>	<input type="checkbox"/>	<input type="checkbox"/>	<input type="checkbox"/>	<input type="checkbox"/>	<input type="checkbox"/>	<input type="checkbox"/>
Other	<input type="checkbox"/>	<input type="checkbox"/>	<input type="checkbox"/>	<input type="checkbox"/>	<input type="checkbox"/>	<input type="checkbox"/>	<input type="checkbox"/>	<input type="checkbox"/>	<input type="checkbox"/>	<input type="checkbox"/>	<input type="checkbox"/>	<input type="checkbox"/>
Other	<input type="checkbox"/>	<input type="checkbox"/>	<input type="checkbox"/>	<input type="checkbox"/>	<input type="checkbox"/>	<input type="checkbox"/>	<input type="checkbox"/>	<input type="checkbox"/>	<input type="checkbox"/>	<input type="checkbox"/>	<input type="checkbox"/>	<input type="checkbox"/>

EXPLAIN FAILING RESULTS AND REQUIRED ACTIONS (specify the associated areas):	RESPONSIBLE PERSON	COMPLETED BY (DATE)	(DATE) COMPLETED

OTHER COMMENTS OR OBSERVATIONS (specify the associated areas):

---

## Aboveground and Underground Storage Tanks

### Best Management Practices

#### Discharge Prevention Procedures for Routine Handling of Products

The factory should implement the following procedures to prevent spills during routine handling of products, such as small-quantity transfers from drums to smaller containers that could result in a discharge:

- Product-handling personnel are trained in appropriate procedures for safely transferring products between containers and minimizing spills.
- Product loading and unloading is performed only by trained and authorized personnel.
- Small-quantity transfers of oil between bulk containers and points of use are accomplished using equipment designed to provide maximum manual control over the amount and rate of product transferred, to avoid minor spills. Such equipment includes hand pumps and dispenser valves/faucets for retrieving products from drums and other portable containers, funnels, and small-diameter hoses or tubing.
- Oil drums are delivered and collected using a vehicle that is equipped with appropriate equipment for raising and lowering drums from the vehicle to the loading area. Drums and other portable containers are moved individually between locations using only equipment designed for such operations (e.g., forklifts, pallets, drum dollies, hydraulic hoists, loaders, etc.) to avoid dropping or tipping the containers.
- Product transfers are typically conducted in areas with local containment structures (e.g., secondary containment sheds or drum stands with secondary containment).
- Drip pans are positioned at points of use to catch drips and overfills.
- Products are transferred between factory areas in closed containers to avoid splashes and drips.
- Containers are maintained closed when personnel are not conducting product transfers.
- Sorbent materials are maintained in product-handling areas for rapid deployment to contain and absorb small quantities of spilled product.

#### Tank Truck Unloading Procedures

The following procedures are required for tank truck unloading of oil:

- All tank truck unloading operations will be monitored fulltime by a properly trained factory worker, in addition to the tank truck operator.
- Tank truck unloading will not be conducted during rain events that produce storm water runoff at the unloading area.
- Tank truck tires will be chocked after the truck has parked and before fuel or transformer oil unloading begins, to prevent departure of the truck before complete disconnection of transfer lines.

- An absorbent boom will be placed on the pavement and/ or ground surface, before unloading begins, in a location and position that will provide temporary secondary containment in the event of a spill during fuel or oil unloading.
- Fuel levels in the factory's aboveground tanks and/or underground tanks will be checked and the volume of fuel to be unloaded from the tank truck determined before filling of the tank(s) begins.
- Visual displays of fuel level gauges at the tank(s) will be monitored continually during the unloading operation.
- Fuel hose disconnects will be managed to ensure small amounts of fuel remaining in the hose drain into the overfill reservoirs of the tank(s) (where present) or back to the truck tank.

Before removing wheel chocks from the tank truck, the lowermost drain and all outlets of the tank truck will be inspected for leaks; hoses and valves will be checked to ensure they are tightly secured/closed; and any necessary adjustments will be made.

#### Underground Storage Tank System—General Guidelines

This document is provided to assist tank owners and operators responsible for maintaining their underground storage tank systems to implement best management practices. By reviewing your factory's conformance with each of these required items, you can improve your working knowledge of your underground tank system and minimize the potential for environmental contamination.

##### A. Administrative

#### Leak Detection System:

- An approved leak-detection monitoring system or program has been installed and is functioning properly.

#### Written Monitoring Records:

All leak-detection monitoring records are maintained on site, including but not limited to:

- Maintenance records for the last 3 years (including periodic equipment calibration)
- Inspection log verifying that the leak-detection system has power and is NOT in alarm
- Alarm printouts (for electronic leak-detection equipment)
- Groundwater or vapor well sampling records (if applicable)
- Inventory reconciliation records

#### Written Monitoring Procedures:

The written leak-detection monitoring procedures have been reviewed to ensure that they include:

- Frequency of the leak-detection monitoring
- Methods and equipment used to perform the leak detection monitoring
- Location of monitoring probes and control (alarm) units



## Written Emergency Response Plan:

The written emergency response plan has been reviewed to ensure that it includes:

- Who to call for equipment service or to investigate alarm conditions
- Procedures for notifying the local fire/hazardous materials agency

## B. Dispensers

### Hoses and Nozzles:

- Hoses are not crimped or collapsed. Nozzles are product tight.

### Leaks/Weeping Joints:

- Pipes are not leaking. Joints are not weeping.

### Containment:

- The containment or area under the dispensers is kept dry at all times. Fuel filters are carefully removed to avoid spillage into the containment or area under the dispensers.
- Fittings/Hose Connectors: Fittings and hose connectors are not disconnected.
- Electrical: Electrical wires are not exposed. There is no open conduit.

### Shear Valves:

- Shear valves have been installed under dispensers to stop product flow resulting from an accident which damages the dispenser. These valves are inspected periodically to verify that they are functional.

## C. Underground Tanks/Piping

### Overspill Containment:

- Each tank fill opening is equipped with an overspill container of at least 20-liter (~5 gallon) capacity. The container is connected to the tank via a plunger or drain. The container is kept dry at all times.

### Overfill Prevention:

To prevent tank overflow during product delivery, each tank is equipped with either:

- A mechanical “flapper-valve” tube which is inserted inside the product fill tube; or
- An electronic sensor which alarms when delivered product reaches 95% of the tank capacity.

### Manway Sumps:

- All manway sumps are maintained in a dry condition. There is no leakage from pipeline detectors or other equipment located inside the sumps. For sumps containing liquid sensors, the sensors are located at the bottom of the sumps.

## D. Leak-Detection Equipment

### Inspections:

All leak-detection equipment is routinely inspected to verify that:

- there is power to the equipment; and
- the equipment is NOT in alarm.

### Calibration:

- All leak-detection equipment (including pipeline leak detectors) is tested and calibrated at least annually.

## E. Miscellaneous

### Emergency Shut-Off Switch:

- A master Emergency Shut-Off Switch is located in an accessible area within sight of all dispensers. This switch is labeled and is maintained in working condition at all times.

### Fire Extinguishers:

- Fire extinguishers with a minimum rating of 2-A:20-B:C are located in accessible areas no further than 23 meters (75 feet) from pumps and dispensers. All extinguishers have been serviced within the last 12 months (verifiable via service tag).

### Cathodic Protection:

- For steel tank systems, a cathodic protection system is installed to protect tank(s)/piping from rusting and deterioration. The system is inspected every three months.

### Signs:

The following signs are provided in the local language: “Smoking Prohibited”; “Dispensing Into Unapproved Containers Is Prohibited”; “Vehicles Must Stop During Fueling Operations”; and:

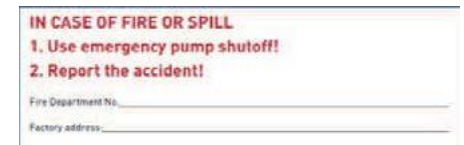

### Guidelines for Testing of Underground Storage Tanks Secondary Containment Systems

These guidelines are applicable to underground storage tank systems (tanks and piping) that store hazardous materials that are liquid at standard temperature and pressure.

## F. Test Frequency

- All secondary containment systems (i.e. tank annular spaces, secondary piping, piping sumps, dispenser containment, etc.) should be tested upon installation, six (6) months after installation, and every 36 months thereafter.
- Exception:** Testing is not necessary for secondary containment systems where a continuous monitoring device automatically monitors both the primary and secondary containment, such as systems that are hydrostatically monitored (e.g. brine-filled annular spaces) or under constant vacuum.

**G. Test Methods and Procedures**

- All secondary containment testing should be performed by either a qualified tank tester, or if required by local laws, a licensed tank tester.
- Periodic testing of secondary containment systems should be conducted using a test procedure that demonstrates that the system performs at least as well as it did upon installation. For example, if the secondary containment system was tested upon installation by using a test method that applied a pressure of 0.34 atm (5 psi), then the periodic test must be conducted using a method that tests the system at an equivalent pressure.
- All testing should be performed in accordance with the secondary containment system manufacturer’s guidelines or standards. If there are no manufacturer’s guidelines or standards, testing should be performed using an applicable method specified in an industry code or engineering standard. (Note: In the case of pressure/vacuum testing, any loss in pressure/vacuum during the course of the test should be considered a failed test, regardless of the manufacturer or other criteria for declaring a passed test.)
- Under no circumstances should any primary containment system for flammable or combustible liquids, or secondary containment system holding a potentially explosive atmosphere, be pressurized with air.
- When a tank manufacturer’s installation guidelines/ standards allow a choice between either pressure or vacuum testing of a tank annular space, it is recommended that vacuum testing be performed. If pressure testing is performed, the primary containment should first be pressurized using nitrogen (or another approved inert gas) to a pressure equal to the intended secondary containment test pressure, so as to prevent undue stress to, or structural failure of, primary containment. Pressure should be maintained on the primary containment until pressure is released from the annular space at the conclusion of testing.
- In cases where water is used for testing of secondary containment systems (e.g. lake testing of sumps), a means should be provided for removing all water at the conclusion of testing. Removed water should be analyzed for contamination by hazardous materials and, if contaminated, properly disposed of at an authorized disposal factory.
- Water removed from secondary containment systems should not be disposed of to the storm water systems or waterways.

**H. Test Notification and Reporting**

- If required by local law, owners/operators of underground storage tanks should notify the local agency prior to conducting testing of secondary containment systems.
- Test reports should be maintained on file, and submitted to the local government authority, if required by law.

**Designated Operator Training Program**

Factory Name: \_\_\_\_\_

Factory Site Address: \_\_\_\_\_ City: \_\_\_\_\_

Designated Underground Storage Tank Operators should provide training to factory workers who have responsibilities associated with the operation and/or maintenance of underground storage tank systems. This training should be provided annually. Initial training should be provided within 30 days of the date of hire. At least one of the factory workers present during operating hours should have current training. This should include the following items:

- Operation of the underground storage tank system in a manner consistent with the factory’s best management practices
- The worker’s role with regard to underground storage tank monitoring equipment as specified in the written underground storage tank monitoring plan
- The worker’s role with regard to spills and overfills as specified in the written underground storage tank response plan
- Name(s) of contact person(s) for emergencies and monitoring equipment alarms
- For factories that are not routinely staffed, factory worker responsibilities as specified in the training program approved by the local regulatory agency.

Factory Worker Name	Training Date	Hire Date	Trainer Name

### Quarterly Inspection Sheet for Site-Owned, Oil-Filled Transformers

	T-1	T-2
Any signs of leakage from transformer surfaces? (Signs might include droplets, drip marks, discoloration)	<input type="checkbox"/> Yes <input type="checkbox"/> No	<input type="checkbox"/> Yes <input type="checkbox"/> No
If yes, describe.	Recommended Action	Date of Implementation
Any readily visible signs of damage or deterioration of secondary containment? (Signs might include cracks, discoloration)	<input type="checkbox"/> Yes <input type="checkbox"/> No	<input type="checkbox"/> Yes <input type="checkbox"/> No
If yes, describe.	Recommended Action	Date of Implementation

**Additional notes:**

---



---



---



---



---



---



---

### Discharge Report Form

Name of Person Making Report :		
Organization : Name & Address		Phone No.
Date of Spill :	Time of Spill :	Material spilled :
Quantity of Spill :		Spill Source :
Location of Spill :		
Person/Organization Discovering the Spill:		
Surface Water Impacted :		Supply Wells Impacted :
1. Did material reach a storm drain or waterway? (If yes, indicate amount)		
2. Cause and circumstances of spill:		
3. Method used to stop spill:		
4. Method used to remove spilled material:		
5. Method used to mitigate effects of discharge:		
6. Method and location of absorbent material or device disposal:		
7. Were any damages or injuries caused by the spill? Was evacuation needed?		
8. Individuals and/or organizations contacted:		
Individual / Organization, Phone #		Date and Time Contacted
9. Time spill originated:		Time spill clean-up completed:
10. Unusual circumstances or pertinent data:		
Signature of person making report:		Date :

# Glossary

**Aerobic Treatment:** A treatment method for wastewater in which the water is aerated to provide oxygen for the microorganisms to convert organic carbon to CO and new cells. This is a very common treatment for wastewater.

**Agent:** In LS&Co. the term “agent” has 2 meanings:

If used when referring to the hiring of workers, agents are organizations or individuals who supply workers for factories. These organizations/individuals can be linked to the government in a country or can be independent. Usually, the agent is paid a fee to provide a guaranteed number of workers. Often, the workers’ labor contracts are with the agent, rather than the supplier who uses the workers. These (hiring) agents are sometimes called Labor Recruitment Services.

SCOC problems can arise if the hiring Agent’s contract with the workers does not meet SCOC requirements (e.g. minimum wage, maximum 60 hours per week).

If used in a sourcing relationship, agent refers to a legal relationship between LS&Co. and an external sourcing organization. The sourcing agent has the legal authority to place production with suppliers for LS&Co. (or the division or brands that have entered into the relationship). Often, it is the agent’s responsibility to select the supplier, control the quality of the goods, and deliver the products on time to the chosen LS&Co. destination. Sourcing agents tend to be used in remote parts of the world, where sourcing requires specialized local knowledge or for unique items that are only available from a few suppliers.

SCOC problems can arise if the sourcing agent is not aware of the SCOC requirements and/or the need to SCOC assess the suppliers before production is placed with them.

**Annual Assessment:** The yearly SCOC assessment that follows the Initial Assessment in an active supplier.

**Applicable Laws and Regulations:** Governing laws, regulations, and authorized agency guidance in both the Sending Country and Receiving Countries.

**Aquifer:** The underground layer of water-soaked sand and rock that acts as a water source for a well.

**Asbestos:** Naturally occurring mineral which separates into long thread-like fibers; does not burn, does not conduct heat or electricity, and is resistant to chemicals. Materials that might contain asbestos include: fire-proof clothing, piping insulation, and sprayed-on ceiling texture.

**Asbestos-Containing Material (ACM):** Any material containing more than 1% asbestos.

**Analytical Report:** A laboratory-generated document containing the results of analyses carried out on wastewater samples, along with other pertinent information relating to the sampling/ analysis exercise.

**Ballast (Electrical Light Ballast):** A component of a fluorescent light fixture that may contain polychlorinated biphenyls (“PCBs”). Usually applies only to ballasts manufactured before 1978.

**Benefits:** Compensation paid to employees in addition to remuneration (wage/salary). Benefits can be classified as legal when stipulated by labor or federal agencies, such as overtime, holiday, or vacation pay. Companies can also provide voluntary benefits, which are not required by law, such as tuition reimbursement or food baskets.

**Berm Walls:** [See Secondary Containment.](#)

**Bonded Labor (or Bondage):** An illegal practice in which employers give high-interest loans to workers who either individually or as an entire family then labor at low wages to pay off the debt.

**Biochemical Oxygen Demand (BOD):** This is the measure of the organic polluting strength of wastewater. The BOD is determined by measuring the oxygen used by microorganisms in the biochemical oxidation of the organic matter in a given volume of waste or natural water. Reported as milligram oxygen per liter (mg/l), essentially equivalent to parts per million (ppm) by weight in the case of liquid water.

**Biodegradability:** The susceptibility of a substance to decomposition by living organisms, mainly microorganisms. Biological Oxygen Demand<sub>5</sub> or BOD<sub>5</sub>: An indirect way of measuring the quantity of organic material present in an effluent that is utilized by bacteria.

**Broker:** A person who is contracted by an employer to recruit workers from the country of origin. Also known as a ‘labor agent’.

**Bunding/Bund Walls:** [See Secondary Containment.](#)

**Chemicals:** “Chemicals” is a common term that describes many different solids, liquids and gases that are used to produce specific effects on other substances. For the purposes of a SCOC assessment, “chemicals” include substances that may be present in all facilities such as paint, oil, degreasers, spot removers and solvents. It also includes specialist laundry and dyeing chemicals used in wet finishing facilities and mills, such as detergents, softeners, surfactants, oxidizers and bleaching agents. SCOC requires that all chemicals at a facility site have Material Safety Data Sheets.

**Bypass:** An intentional diversion of wastewater from the collection system or wastewater treatment plant.

---

**Child Labor:** The employment of workers under 15 years of age, or below the minimum work age required by law, if such age is above 15.

**CI:** [See Continuous Improvement Item.](#)

**COD (Chemical Oxygen Demand):** A measure of the polluting strength of wastewater (especially industrial effluents). COD is determined by measuring the oxygen used by a strong oxidizing agent to chemically oxidize the organic matter in a given volume of waste or natural water. Normally COD is higher than BOD is, as more inorganic and organic substances can be oxidized chemically than biologically. Reported like BOD, as mg/l.

**Code of Conduct:** The internationally applied name for company workplace standards such as the LS&Co. Supplier Code of Conduct.

**Coercive Behavior:** Any behavior that threatens or pressures individuals to work against their will. This can be direct or indirect.

**Collective Bargaining:** Negotiations between an employer and a group of employees that determine the conditions of employment. The result of the collective bargaining procedure is called the collective (bargaining) agreement. Often, employees are represented in the bargaining by a trade union or other labor organization.

**Collective (Bargaining) Agreement:** An agreement negotiated between a group of employees (often a trade union) and an employer that sets forth the terms of employment for the employees who are members of that group of employees. This type of agreement may include provisions regarding wages, vacation time, working hours, working conditions, and health insurance benefits.

**Combustible Liquid:** Any liquid having a flash point at or above 37.8° Celsius.

**Community Involvement:** An Activity (usually philanthropic) conducted by a company within the community in which the company or in which its employees reside. Examples include supporting children's athletic leagues, providing construction materials for schools, making financial contributions for emergency relief, etc.

**Compliance:** Following or meeting the obligations of a rule, agreement or guideline.

**Composite Sample:** A mixture of grab samples collected at the same sampling point at different times, formed either by continuous sampling or by mixing discrete samples. May be a "time-composite" (collected at constant time intervals) or "flow-proportional" (collected either as a constant sample volume at time intervals proportional to stream flow or collected by increasing the volume of each grab sample as the flow increases, while maintaining a constant time interval between the grab samples).

**Continuous Improvement Item:** Labor, health & safety, and environmental issues that can be improved in the factory for the well-being of workers and/or betterment of its reputation

---

or management practice. Production can be placed in proposed suppliers with CI issues. For proposed and existing suppliers with CI issues, a reasonable corrective action plan can be proposed over a 6-month period.

Examples of CI include operating permits (if company has already applied for them), establishment of company policies on hiring practices, etc., records documentation, health & safety issues such as PPE, chemical storage, first aid, machine guarding, signage, etc.

**Contract Workers:** Workers who are hired for a specific period of time to conduct a certain kind of work as described and agreed to on the basis of a contract. In some parts of the world contract workers are taken into a second country under a labor contract that may not provide the workers with the same rights as the local workers. For example, the contract may prohibit the worker from quitting his/her job and seeking work at another facility.

**Contractor:** Supplier, factory, vendors or any person or entity that provides goods and services to the Brand or to another person or entity for use in the Brand's products.

**Corrosive:** Corrosive materials are acidic or basic materials that are capable of corroding metal such as tanks, containers, drums, and barrels.

**Corporal Punishment:** Any disciplinary practice that involves bodily contact or harm, or the threat of bodily harm.

**Country Assessment:** The Country Assessment is one part of LS&Co.'s Global Sourcing and Operations Guidelines. The country assessment evaluates a country's sourcing potential based on the general conditions found in that country for the following issues: Health and Safety, Political Conditions, Economic Conditions, and Social Conditions. LS&Co. Government Affairs and Public Policy is responsible for developing Country Assessments and making recommendations to the business. Recommendations are based on criteria that assess whether the desired sourcing country has met LS&Co.'s requirements.

**CPR:** Cardiopulmonary Resuscitation. A first aid technique used to start a person's heart beating again after the heart has stopped beating due to accident or illness. CPR is a specific technique that requires proper training.

**Decibel (dB):** Unit of measure used to evaluate noise level of equipment or machinery during use. Acceptable noise levels should not exceed 85 decibels during an eight-hour (or longer) work period.

**Detection Limit:** The minimum concentration of a substance that can be measured and reported with 99% confidence that the parameter concentration is above zero and is determined from analysis of a sample in a given matrix containing the parameter.

---

**Disciplinary Practice:** Actions used by managers or supervisors to change the behavior of employees.

**Discrimination:** Practices that use religion, sex, ethnicity or national origin, disability, political affiliation, social status, sexual orientation, actual or perceived HIV status or legal migrant worker status as a basis for hiring, compensation, promotion, termination and retirement practices and access to training and not a person's ability to perform a job.

**Domestic Worker:** An individual whose nationality/country of origin is the same as that of the country in which Supplier's facility is located.

**Ecolabels:** Official or unofficial marks of ecological or environmental approval.

**Egress:** Means of exit out of a building or area.

**Electrical Light Ballast:** See Ballast.

**Emergency Alarm:** System used to identify or warn of emergency within a work site. The system can utilize electrical or manual warning devices.

**Engineering Report:** A report produced and signed by a professional licensed engineer, which thoroughly examines the technical, engineering and administrative aspects of a wastewater treatment plant.

**Environment:** Surroundings in which an organization operates, including air, water, land, natural resources, flora, fauna, humans, and their interrelation.

**Ergonomic Assessment:** Review of the worker and his/ her working environment that determines the frequency of repetitive actions and identifies hazards of specific workplace conditions. The areas of ergonomics are such tasks as computer data entry or sewing, pressing, or cutting fabrics.

**Export Processing Zones (EPZs):** Free Trade Zones (FTZs) or Qualified Industrial Zones (QIZs) are government-approved industrial areas that are exempt from some (or all) of the normal commercial laws of the country that they are in. Sometimes the country's minimum wage laws and/or other labor laws do not apply to workers in these zones.

**External Monitor:** A third party hired by LS&Co. or one of LS&Co.'s business partners to conduct SCOC assessments in place of an internal SCOC assessor.

**Facility Headquarters:** The registered office of the company that owns the facility that is being SCOC assessed.

**Facility Site:** The specific factory that is being SCOC assessed, including workplaces and all facility land, structures and other improvements on the land owned or leased by the facility.

**First Aid:** Emergency treatment for injury or sudden illness administered before regular medical care is available.

---

**Flammable:** Capable of being easily ignited and of burning with extreme rapidity. Examples include liquids, such as solvents and fuels that readily catch fire when exposed to a spark or flame.

**Flammable Liquid:** Any liquid having a flash point below 37.8° Celsius, except any mixture having components with flash points of 37.8° Celsius or higher, the total of which make up 99 percent or more of the total volume of the mixture.

**Flash Point:** The lowest temperature of a liquid at which it gives off enough vapor to form an ignitable mixture with air near the surface of the liquid with the storage container open.

**Follow Up Assessment:** The assessment that usually follows an initial or annual SCOC assessment. The SCOC assessor conducts a follow-up assessment if the factory had corrective actions to make based on discoveries in the initial or annual assessment.

**Foot Candle:** A unit for measuring illumination; it is equal to the amount of direct light thrown by one international candle on a square foot of surface every part of which is one foot away.

**Forced Labor:** Any arrangement in which workers are forced to work against their will or do not have the choice to leave their working arrangement when they choose.

**Freedom of Association (FoA):** Freedom of association is often referred to in the context of forming or joining a workers' trade union. Joining a union is an example of people exercising their right to freely associate. However, FoA is not limited to trade union activities. FoA means that people should be able to form any type of organization or join any type of organization without persecution or hindrance from the government or other people (such as their employer). Some governments place legal restrictions on what type of organizations can be formed under the right to freely associate e.g., a common restriction is preventing the formation of an organization for criminal purposes.

**Friable:** Material that, when dry, can be crumbled, pulverized, or reduced to powder by hand pressure. This includes non-friable materials that, during the course of renovation or other activities, can become "friable".

**Global Sourcing and Operating Guidelines (GSOG):** The LS&Co. requirements that are applied to every contractor or supplier that manufactures or finishes product for LS&Co. The GSOG have 2 parts: The Country Assessment Guidelines and our Supplier Code of Conduct .

**Global Warming:** The increasing temperature of the atmosphere due (principally) to the burning of fossil fuels like coal, gas and oil in power stations and vehicles.

**Grab Sample:** A single sample or measurement taken at a specific time or over as short a period of time as is feasible.

**Groundwater:** The supply of freshwater found below the Earth's surface (usually in aquifers) which is also used for supplying wells and springs.

---

**GSOG:** [See Global Sourcing and Operating Guidelines.](#)

**Hazardous Labor:** Labor or work that places the worker in physical or psychological harm; requires the use of dangerous machinery; places the individual in unhealthy environment due to the materials used; or places the worker in difficult physical conditions. (Review the section on Child Labor for the definitions of hazardous work in regard to young workers.)

**Hazardous Waste:** Waste that poses a risk to human health or the environment and requires special disposal techniques to make it harmless or less dangerous. These wastes may be regulated by national or international guidelines. A waste may be considered hazardous if it is ignitable (i.e., burns readily), corrosive, or reactive (e.g., explosive). Waste may also be considered hazardous if it contains certain amounts of toxic chemicals. Hazardous waste takes many physical forms and may be solid, semi-solid, or even liquid.

**Hiring Agent:** [See Agent.](#)

**IA:** [See Immediate Action Item.](#)

**Illegal Activity:** Engaging in activity which is against established law. Examples of illegal activity or behavior include keeping two sets of payroll documents in order to defraud the local government on payroll taxes, management willfully ignoring the law in contractual agreements, or the company willfully ignoring legal judgments in a lawsuit.

**Immediate Action Item:** Breach of Supplier Code of Conduct that results in negative impact to individual rights and life safety and/or LS&Co.'s corporate reputation. Production cannot be placed in proposed suppliers with IA violations. For existing suppliers with an IA, the violation must be remediated fully (e.g., underpaid wages must be repaid) and within a maximum period of 2 months, or the issue becomes a ZT. Some IA violations may require a remediation period of less than 2 months.

Examples of IA include excessive working hours, non-payment of overtime premiums or contracted wages, non-provision of required government benefits, documentation on important labor issues such as age, hours, wages; proper disciplinary processes, discrimination, infringements on freedom of association, violations of local law, non-functioning water treatment facility, life safety violations (emergency exits, fire prevention).

**Incompatible materials:** When certain materials are mixed together and produce a reaction such as a fire or explosion. Incompatible materials should be physically separated in the storage area.

**Indentured Labor:** Work, performed by an individual contractually bound to an employer for a specific time period, which is usually in return for payment of travel and living expenses. Indentured laborers may work on behalf of another person's debt. For example, a child who works as an indentured laborer to pay off a parent's debt.

---

**Independent Evaluation:** The use of an independent, third party to evaluate specific activities, behavior or facilities.

**Independent Monitoring:** A program or system in which an independent, third-party organization assumes the responsibility for monitoring specific activities, behavior or facilities.

**Indicator:** Something used to show the existence of a particular activity, behavior, substance or state of being.

**Industrial Wastewater:** Water or liquid-carried waste from wet processing of apparel.

**Initial Assessment:** First SCOC assessment conducted at a specific facility site.

**Labor Recruitment Services:** [See \(Hiring\) Agent.](#)

**Leachate:** Liquid from waste dumps (landfill sites) that forms when rainfall or other water drains through the site and picks up polluting materials.

**Licensee:** LS&Co. has 2 types of licensees—Country Licensee and Product Licensee.

Country licensees include all persons or entities that have a written Licensing Agreement with LS&Co. (or its divisions or brands) to manufacture and sell products bearing the name, trademarks and/or images of LS&Co., within a specified country.

Product licensees include all persons or entities that have a written Licensing Agreement with LS&Co. (or its divisions or brands) to manufacture specified products bearing the name, trademarks and/or images of LS&Co.

**Local Limits:** Specific limits on pollutant parameters developed by local country legislation, regional or municipal authorities.

**Lock Out/Tag Out:** Procedures designed to prevent accidental release on an electrical, pneumatic, hydraulic or any mechanical equipment; the machinery is "locked" or "tagged" to prevent it from operating.

**Lux:** Unit of illumination, equal to one lumen per square meter or to the illumination of a surface uniformly one meter distant from a point of source of one candle.

**Machine Guard:** A machine guard is a device designed to protect workers from points of operations, revolving and rotating parts, live electrical contacts, and other parts of machines and operations.

**Material Safety Data Sheet ("MSDS"):** Provides detailed information on each hazardous chemical contained in a chemical product, including the proportion of each chemical, and the potential hazardous effects, physical and chemical characteristics, and recommendations for appropriate human protective measures. An MSDS does not identify whether a material is a hazardous waste.

---

**Mental Coercion:** The act of restraining or dominating by nullifying individual will. Examples include humiliation, insults, peer pressure or social intimidation.

**Migrant Worker, Migrant:** A person who is to be engaged, is engaged or has been engaged in a remunerated activity in a State of which he or she is not a national.

**Monthly Net Wages:** The amount equivalent to one month's expected wages for the Worker including anticipated overtime hours. This monthly amount shall not exceed the amount of wages based on a 60-hour workweek, including regular and overtime hours after deductions.

**MSDS:** [See Material Safety Data Sheet.](#)

**NGO:** See Non-Governmental Organization.

**Non-compliance:** Violation or failure to follow the obligations of a rule, agreement, or guideline.

**Non-friable:** Material that, when dry, cannot be crumbled, pulverized, or reduced to powder by hand pressure.

**Non-Governmental Organization (NGO):** An organization that is neither a private or public business, nor a government entity. These organizations take many forms and have a variety of missions. Often, NGOs must meet certain legal requirements and be registered with the government to be officially recognized as an NGO. Sometimes, but not always, the NGO is also a "not for profit" organization.

**Not-for-Profit: Organizations that provide services or review/assessment without generating revenues but receive monies from grants issued by public groups, corporations, or government agencies.** Examples of not-for-profit organizations are Save the Children, Amnesty International, and OXFAM. ([See NGO](#))

**On-Premises Supplier:** Workers on a facility site that are engaged in the daily work of the factory but are on the pay role of another organization, such as a hiring agent. Examples of common on-premises suppliers are Cleaners and Security Guards.

**Overall Rating:** When all the sections of the SCOC questionnaire have been completed and all the Section ratings have been assigned, the overall rating is given as the most serious of the Section ratings (e.g., ZT is more serious than IA).

**Overtime Premium:** This is a wage paid above the normal daily or hourly wage to compensate for time worked beyond the normal working schedule. This premium should be described in a country's labor laws.

**Oxidation:** The addition of oxygen, removal of hydrogen, or the removal of electrons from an element or compound. In wastewater treatment, organic matter is oxidized to more stable substances.

---

**Oxidizer:** A substance that gains electrons in a chemical reaction. Oxidizers are generally recognizable by their structures or names. They tend to have oxygen in their structures and often release oxygen as a result of thermal decomposition. Oxidizers often have prefixes (peroxides) and often end in "ate" (nitrate).

**PCB:** [See Poly-Chlorinated Bi-phenyl.](#)

**Personal Protection Equipment (PPE):** Safety equipment worn by employees to protect against physical hazards. Examples of PPE: eyewear, face shields, ear plugs, hard hats, gloves, foot protection.

**pH:** An expression of the intensity of the basic or acid condition of a liquid. Mathematically, pH is the logarithm (base 10) of the reciprocal of the hydrogen ion condition. An exactly neutral solution has a pH value of 7.0.

**Physical Coercion:** Physically restraining or dominating by nullifying individual will. This may be in the form of physical actions or threats of bodily harm.

**Poly-Chlorinated Bi-phenyls (PCBs):** Exposure to PCBs can cause adverse health effects. PCBs are chemicals manufactured for a variety of industrial uses. PCBs are usually clear or yellow oils and exhibit excellent electrical insulating and fire-resistant properties. Primary uses include: Electrical light Ballast insulators; Electrical insulating fluids found in common electrical equipment such as transformers, capacitors, electromagnets, etc.; Heat transfer fluids found in many heat exchangers. PCBs belong to a broad family of organic chemicals called chlorinated hydrocarbons. There are over 200 different PCB compounds that are classified according to their chlorine content.

**Pre-Treatment:** Any wastewater treatment process that takes place on site prior to the discharge of the wastewater to the municipal sewers leading to the POTW, usually consisting of screening and sludge conditioning and dewatering.

**Prison Labor:** Arrangements in which prisoners are used as part of the work force. Under prison labor arrangements, prisoners may be brought to the facility, or the production may occur in the prison facilities. Although prisoners may be paid, because they often have no choice to refuse the work, this is often a kind of forced labor.

**Publicly Owned Treatment Works (POTW):** Publicly owned systems for treating liquid municipal sewage and industrial waste. May also be referred to as wastewater treatment plants and/or waste pollution control plants.

**Quality Assurance:** A series of planned, routine activities which a laboratory carries out to ensure that a product or service complies with the specified quality requirements.

**Quality Control:** A series of operating methods and activities which are used to satisfy compliance with the established quality requirements.



---

**Reactive:** Materials that are unstable when they come in contact with air and water. They can create explosions and/or toxic fumes, gases, and vapors when mixed with water or air. Some reactive materials are often referred to as oxidizers.

**Receiving Country:** A State where the migrant worker is to be engaged, is engaged or has been engaged in a remunerated activity at the contractor's facility.

**Recruitment:** The engagement of a person in one territory on behalf of an employer in another territory, or the giving of an undertaking to a person in one territory to provide him with employment in another territory, including the seeking for and selection of would-be emigrants and the preparation for departure of the emigrants.

**Recruitment Agencies:** A fee-charging employment agency that carries out, under contract, and in exchange for financial compensation, operations on behalf of the Contractor, to ease or speed up access to employment procurement or career progression by filling a vacancy.

**Rules of Origin:** Rules referring to governmental requirements for properly labeling products with the "Made in (country)" statement. Where garment production begins in one country, is finished in a second country and returned to the first country for packing and shipment, the Rules of Origin can be complex. Often Export Processing Zones (EPZs) have special rules that allow them to make garments with another country's "Made in . . ." label.

**Secondary Containment:** Apparatus installed around storage devices, such as tanks or containers, to prevent wastes or accumulated liquids from leaking into the soil, groundwater or surface water by capturing any leaks. Secondary containment devices include double-walls, liners, vaults, spill baths, Bund(ing) or Berms. Sometimes secondary containment is an area that is sloped to drain into a sump or holding area where materials are collected.

**Sending Country:** The country of which the migrant worker is a national; country of origin.

**Seniority (Tenure):** A privileged status attained by length of continuous service at a company.

**Sludge:** Sludge is a term used to describe solids that are removed from wastewater after treatment. Sludge is a slurry of solids and liquid and may be thought of as one of three types: raw, biological or chemical.

**Solids:** The matter that remains a residue upon evaporation and drying at 103° to 105°C.

**Solvent:** A liquid that is used to dissolve active ingredients in a product.

**Sourcing Agent:** [See Agent.](#)

**Spill:** When a chemical product, waste or material is released from its proper container into an area where it was not intended to be.

---

**Standard:** A technical document stating the accepted rules for conducting a specific analytical test.

**State Entities:** Agencies or organizations that are sponsored or managed by the government and/ or act on behalf of the government.

**Stormwater:** Rainwater and other runoff from natural storms. Storm water discharge associated with industrial activity is sometimes regulated when the storm water has contacted manufacturing, processing or raw material storage areas at an industrial plant, and which is discharged to the environment.

**Subcontracting/Subcontractor:** **When a supplier or contractor of LS&Co. pays another company to do the work that LS&Co. has paid the primary supplier/contractor to provide, this is subcontracting.** For example, a tops supplier agrees to deliver 10,000 woven tops, but does not have the capacity to make these tops for the agreed delivery date. The supplier subcontracts with another tops manufacturer to make 5000 tops so that the supplier can make the LS&Co. delivery date. Another example of subcontracting is when a supplier cuts the fabric pieces for a garment and then subcontracts the sewing of the garment to another company. The sewn garment is then returned to the original supplier for packing and shipment. LS&Co. does not allow sub-contracting without prior SCOC approval. The LS&Co. Supplier Code of Conduct apply to sub-contractors.

**Supplier:** A company, individual or organization that supplies goods or services to LS&Co. ([see contractor](#)).

**Supplier Code of Conduct (SCOC):** The LS&Co. Business Partner Supplier Code of Conduct are part of the LS&Co. Global Sourcing and Operating Guidelines (GSOG) that apply to individual companies that supply LS&Co. These guidelines deal with issues that are substantially controllable by the individual business owners, e.g., workplace conditions and hiring practices. The other part of the GSOG is the Country Assessment Guidelines.

**SCOC:** [See Supplier Code of Conduct](#) .

**SCOC Questionnaire:** The document that is completed during the Supplier Code of Conduct assessment. From the information gathered on this questionnaire, the SCOC rating for the facility is determined.

**Total Solids:** The combined total of dissolved solids and suspended solids.

**Total Suspended Solids (TSS):** Particulate matter contained in a water or wastewater samples.

**Toxic:** Materials are harmful or fatal when ingested or absorbed into the body. Another term that means the same or similar thing is "poisonous."

**Verification Assessment:** An assessment that takes place in addition to the Annual Assessment, with the aim of verifying that the information in the SCOC report accurately represents the conditions in the factory assessed.

---

**Wages:** Monetary compensation (money) paid to workers for producing goods or providing services.

**Wastewater:** Process water that contains chemicals or additives generated throughout manufacturing processes.

**Zero Tolerance Violation (ZT):** A Zero Tolerance Violation is a serious breach of Supplier Code of Conduct that LS&Co. believes could result in severe impact to individual rights, life safety, and/or LS&Co.'s corporate reputation. Production cannot be placed in proposed suppliers with ZTVs. For existing suppliers with a ZTV confirmed by more than one source of information, LS&Co.'s approach is to work with these suppliers to remediate ZTVs immediately, and endeavor to limit exit to circumstances when a supplier is unwilling to remediate promptly or does not have the capability to do so.

Examples of ZTV include underage workers; forced labor; corporal punishment; violation of ethical standards; infringements on freedom of association; failure to entitle legal minimum wage; egregious working hours; falsification of records; unauthorized subcontracting; and failure to complete ZT or IA+ corrective actions within the agreed-upon timeframe.

---

## **ACKNOWLEDGMENTS:**

Icons used throughout from the Noun Project: Gathering Point by Fatahillah, Presentation by Jesus Puertas, Eco factory by Eucalyp, Diagnostic Review by Yogesh More, Eye by Josy Dom Alexis